

FEAL

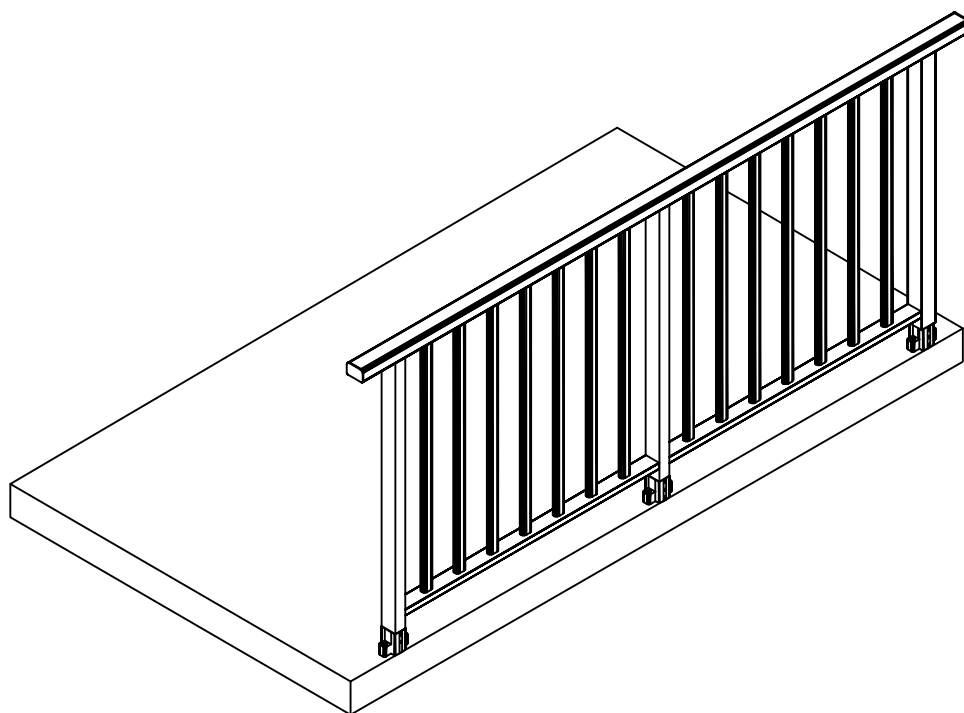

OF 60

ALUMINIJSKA OGRADA
ALUMINIUM FENCE

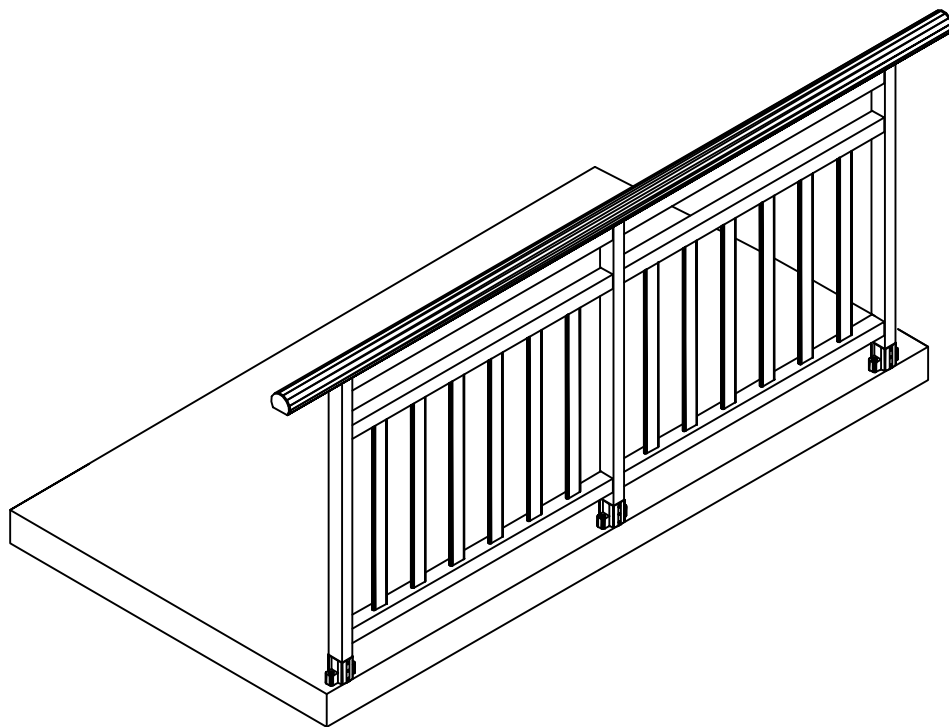

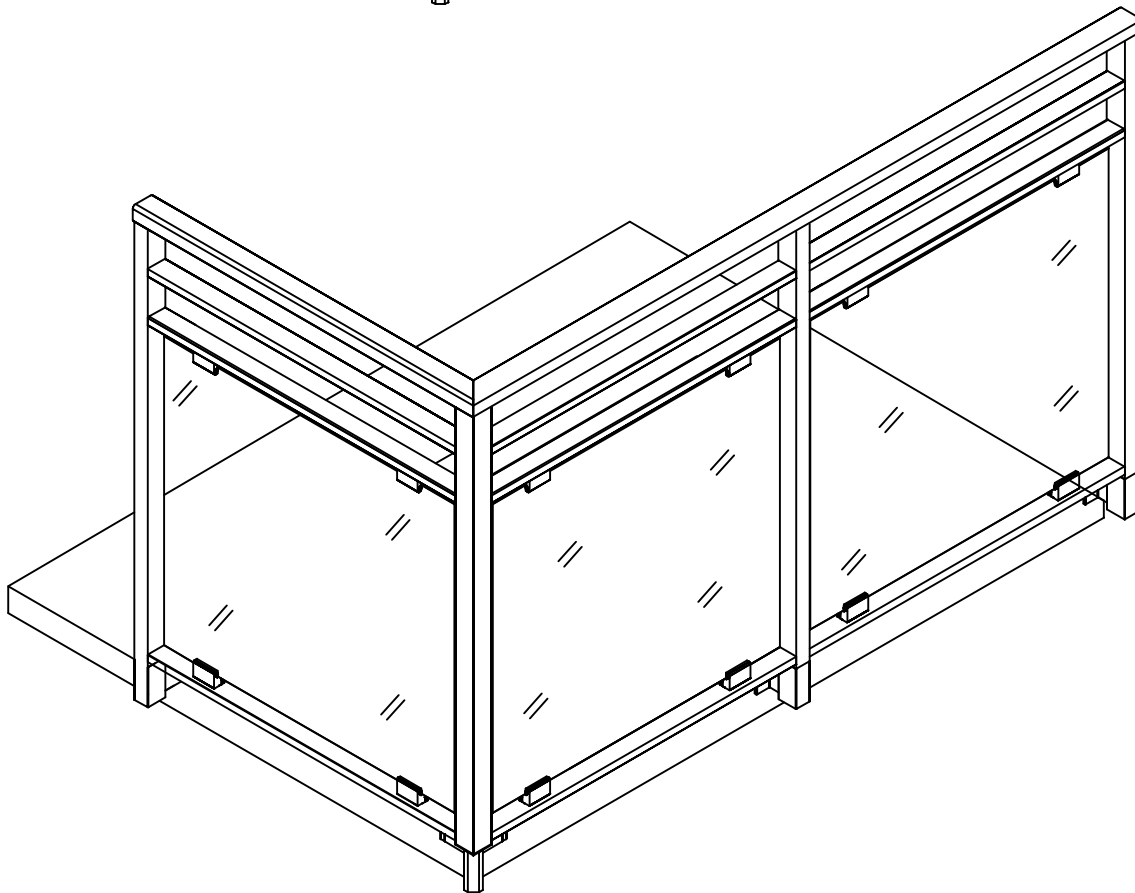
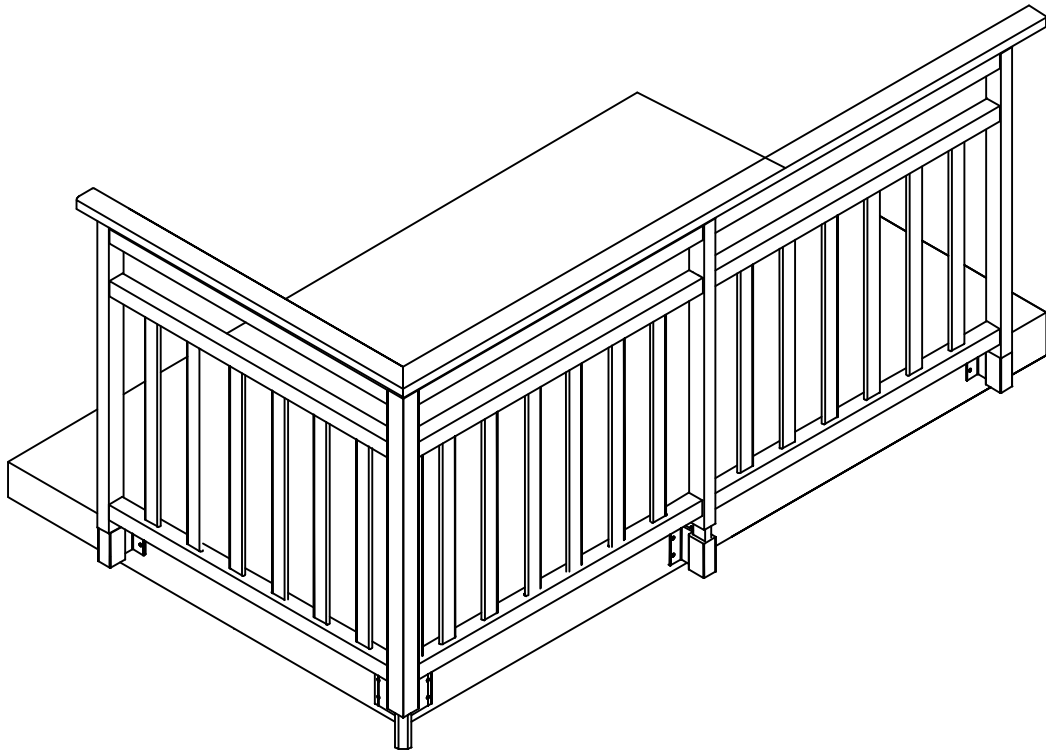

SADRŽAJ - KAZALO

02	Profili	701.03.000-013
03	Vezni elementi	701.04.000-007
04	PVC komponente	701.05.000-003
05	Presjeci	701.10.000-025
06	Obrada i montaža	701.11.000-057
07	Rezne liste	701.12.000-005

Profili

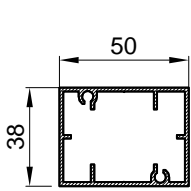

OG-101
kg/m 0.854

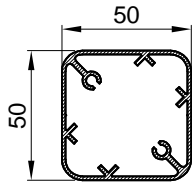

OG-102
kg/m 1.056

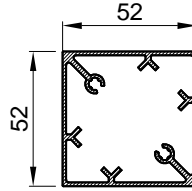

F-1247
kg/m 1.209

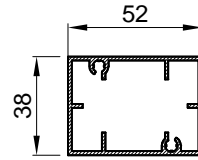

F-1246
kg/m 0.892

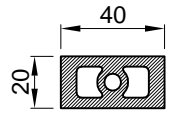

F-0200
kg/m 1.499

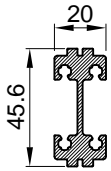

F-1855
kg/m 1.0097

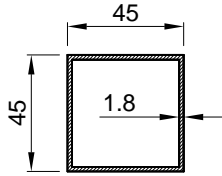

F-0048
kg/m 0.840

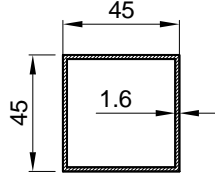

F-0048/A
kg/m 0.750

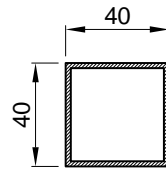

F-0174
kg/m 0.829

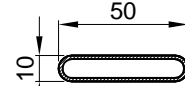

F-0187
kg/m 0.397

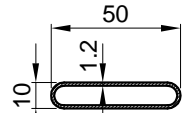

F-0187/A
kg/m 0.349

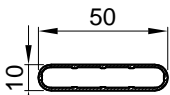

F-0187/L
kg/m 0.307

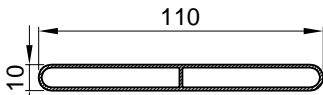

F-1068
kg/m 0.760

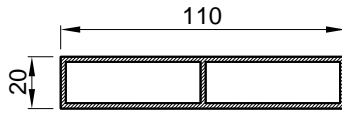

F-0062
kg/m 1.45

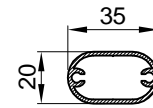

OG-111
kg/m 0.440

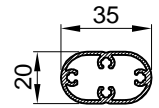

F-1849
kg/m 0.5

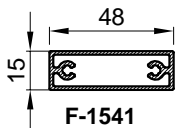

F-1541
kg/m 0.618

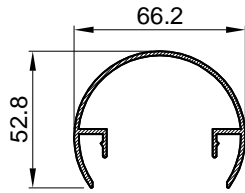

F-0621
kg/m 0.831

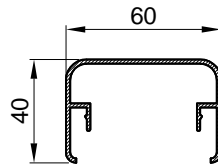

F-0689
kg/m 0.740

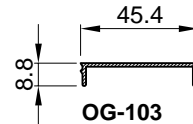

OG-103
kg/m 0.224

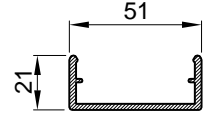

F-0620
kg/m 0.619

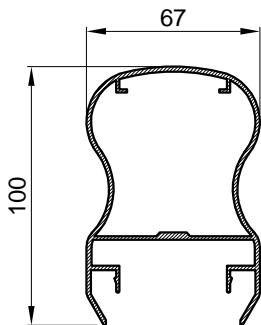

F-0673/A
kg/m 1.735

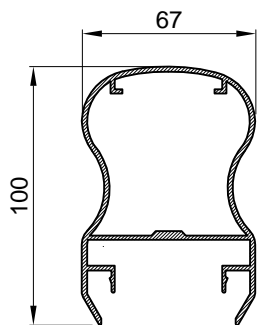

F-0673
kg/m 1.925

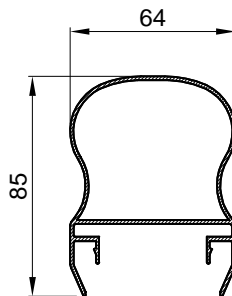

F-1334
kg/m 1.185

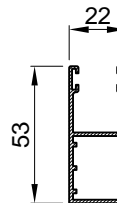

F-0608
kg/m 0.607

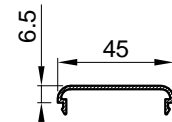

M45-756
kg/m 0.225

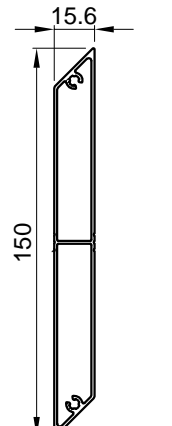

F-1845
kg/m 1.1313

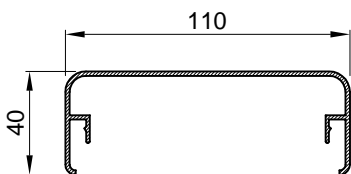

F-1096
kg/m 0.970

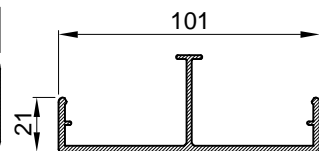

F-1097
kg/m 1.148

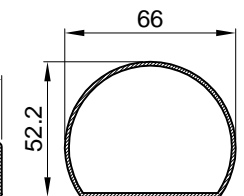

F-1191
kg/m 0.784

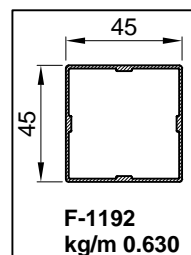

F-1192
kg/m 0.630

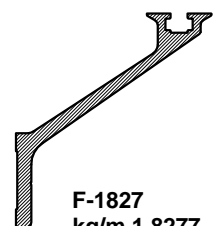

F-1827
kg/m 1.8277

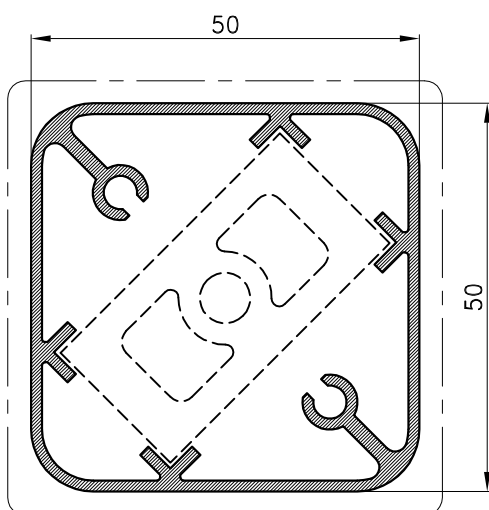

Profil		
Art.-Br.	OG-102	
Težina	kg/m	1.056
Opseg	mm	186
Moment inercije	I_x (cm ⁴)	13.25
	I_y (cm ⁴)	13.26
	W_x (cm ⁴)	5.30
	W_y (cm ⁴)	5.30
Dužina isporuke	mm	6500

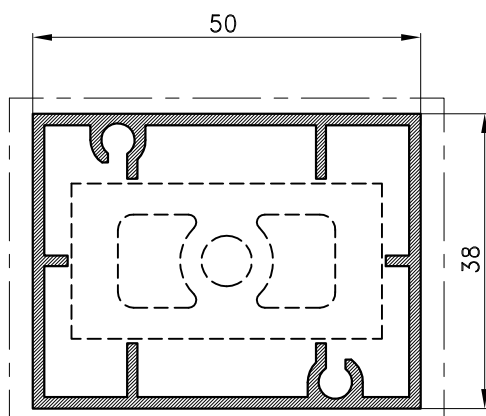

Profil		
Art.-Br.	OG-101	
Težina	kg/m	0.854
Opseg	mm	176
Moment inercije	I_x (cm ⁴)	7.1990
	I_y (cm ⁴)	10.6421
	W_x (cm ⁴)	3.7869
	W_y (cm ⁴)	4.2568
Dužina isporuke	mm	6500

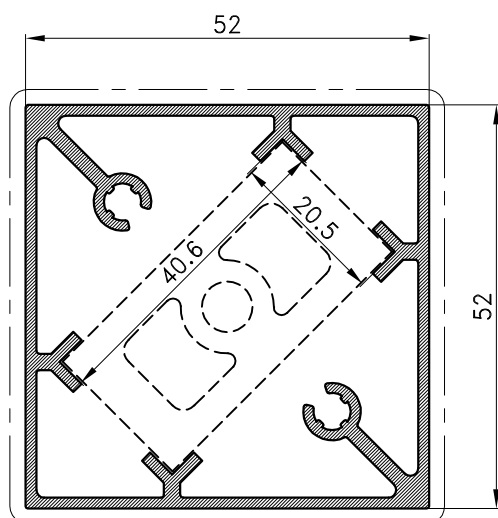

Profil		
Art.-Br.	F-1247	
Težina	kg/m	1.209
Opseg	mm	207.5
Moment inercije	I_x (cm ⁴)	16.95
	I_y (cm ⁴)	16.95
	W_x (cm ⁴)	6.52
	W_y (cm ⁴)	6.52
Dužina isporuke	mm	6500

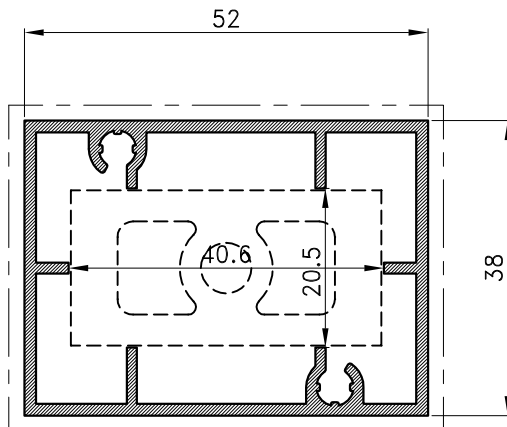

Profil		
Art.-Br.	F-1246	
Težina	kg/m	0.892
Opseg	mm	180
Moment inercije	I_x (cm ⁴)	7.47
	I_y (cm ⁴)	11.83
	W_x (cm ⁴)	3.39
	W_y (cm ⁴)	4.55
Dužina isporuke	mm	6500

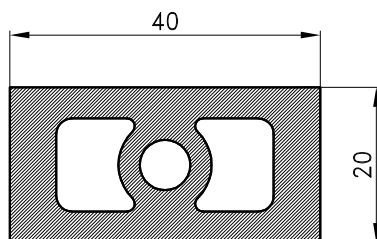

Profil		
Art.-Br.	F-0200	
Težina	kg/m	1.499
Opseg	mm	120
Moment inercije	I_x (cm ⁴)	2.39
	I_y (cm ⁴)	8.63
	W_x (cm ⁴)	2.39
	W_y (cm ⁴)	4.31
Dužina isporuke	mm	6500

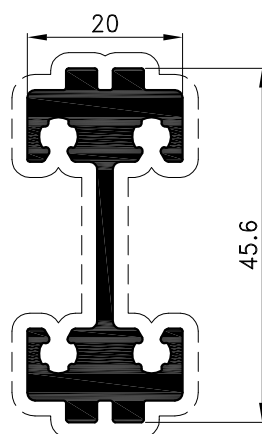

Profil		
Art.-Br.	F-1855	
Težina	kg/m	1.0097
Opseg	mm	224.91
Moment inercije	I_x (cm ⁴)	9.63
	I_y (cm ⁴)	0.96
	W_x (cm ⁴)	4.22
	W_y (cm ⁴)	0.96
Dužina isporuke	mm	6500

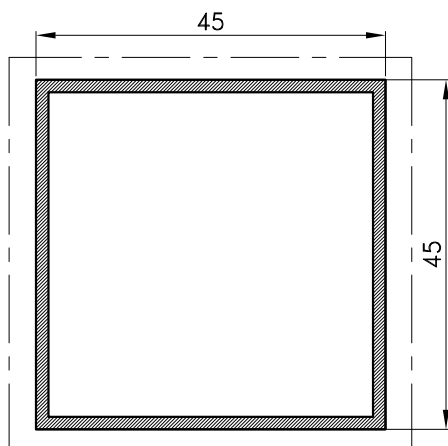

Profil		
Art.-Br.	F-0048/A	
Težina	kg/m	0.750
Opseg	mm	180
Moment inercije	I_x (cm ⁴)	8.73
	I_y (cm ⁴)	8.73
	W_x (cm ⁴)	3.88
	W_y (cm ⁴)	3.88
Dužina isporuke	mm	6000

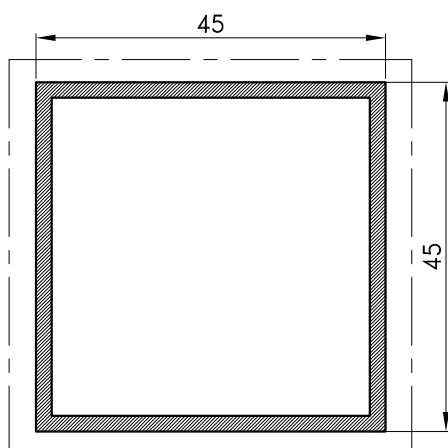

Profil		
Art.-Br.	F-0048	
Težina	kg/m	0.84
Opseg	mm	180
Moment inercije	I_x (cm ⁴)	10.62
	I_y (cm ⁴)	10.62
	W_x (cm ⁴)	4.72
	W_y (cm ⁴)	4.72
Dužina isporuke	mm	6500

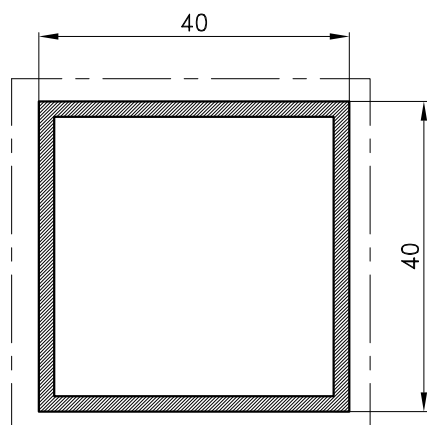

Profil		
Art.-Br.	F-0174	
Težina	kg/m	0.829
Opseg	mm	160
Moment inercije	I_x (cm ⁴)	7.34
	I_y (cm ⁴)	7.34
	W_x (cm ⁴)	3.67
	W_y (cm ⁴)	3.67
Dužina isporuke	mm	6000

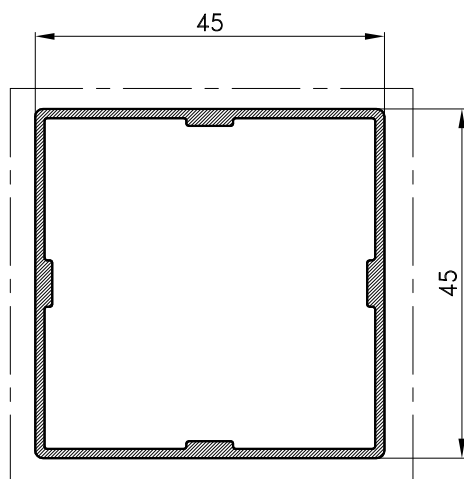

Profil		
Art.-Br.	F-1192	
Težina	kg/m	0.630
Opseg	mm	180
Moment inercije	I_x (cm ⁴)	7.21
	I_y (cm ⁴)	7.21
	W_x (cm ⁴)	3.20
	W_y (cm ⁴)	3.20
Dužina isporuke	mm	6000

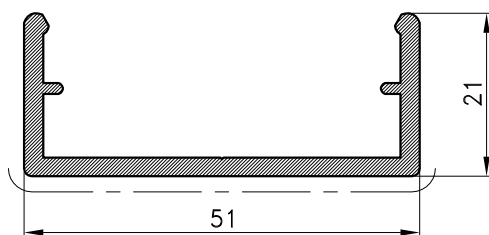

Profil		
Art.-Br.	F-0620	
Težina	kg/m	0.600
Opseg	mm	188
Moment inercije	I_x (cm ⁴)	0.88
	I_y (cm ⁴)	8.43
	W_x (cm ⁴)	0.58
	W_y (cm ⁴)	3.31
Dužina isporuke	mm	6500

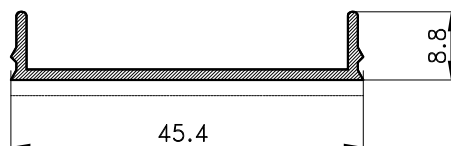

Profil		
Art.-Br.	OG-103	
Težina	kg/m	0.224
Opseg	mm	122
Moment inercije	I_x (cm ⁴)	0.04
	I_y (cm ⁴)	1.97
	W_x (cm ⁴)	0.05
	W_y (cm ⁴)	0.87
Dužina isporuke	mm	6500

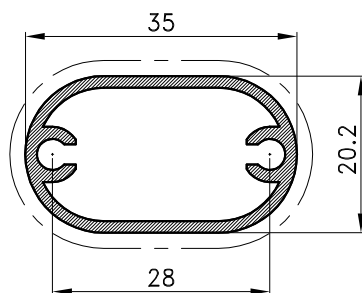

Profil		
Art.-Br.	OG-111	
Težina	kg/m	0.44
Opseg	mm	93
Moment inercije	I_x (cm ⁴)	0.78
	I_y (cm ⁴)	2.28
	W_x (cm ⁴)	0.78
	W_y (cm ⁴)	1.30
Dužina isporuke	mm	6500

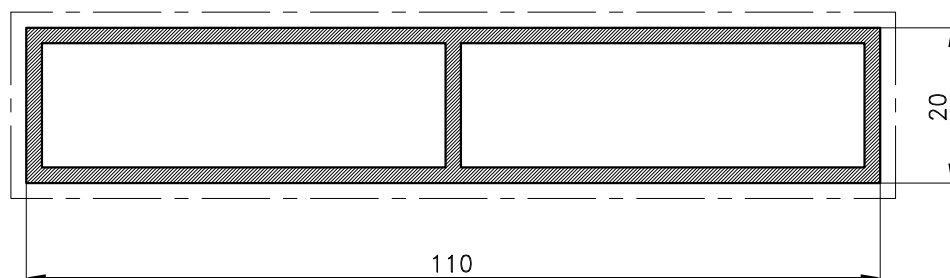

Profil		
Art.-Br.	F-0062	
Težina	kg/m	1.45
Opseg	mm	260
Moment inercije	I_x (cm ⁴)	3.78
	I_y (cm ⁴)	63.03
	W_x (cm ⁴)	3.78
	W_y (cm ⁴)	11.46
Dužina isporuke	mm	6500

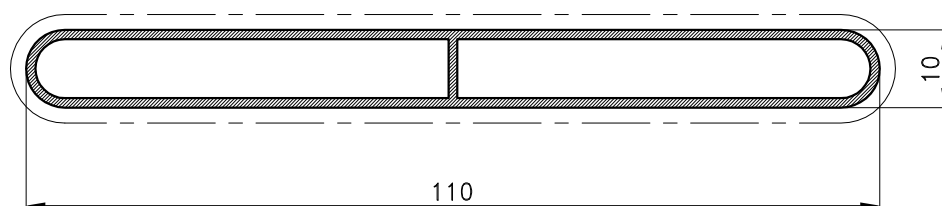

Profil		
Art.-Br.	F-1068	
Težina	kg/m	0.760
Opseg	mm	231
Moment inercije	I_x (cm ⁴)	0.50
	I_y (cm ⁴)	29.26
	W_x (cm ⁴)	1.01
	W_y (cm ⁴)	5.32
Dužina isporuke	mm	6500

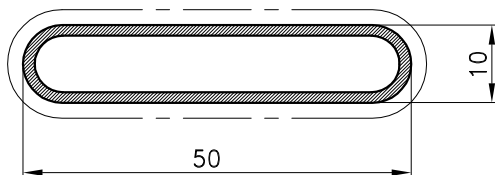

Profil		
Art.-Br.	F-0187	
Težina	kg/m	0.397
Opseg	mm	111
Moment inercije	I_x (cm ⁴)	0.24
	I_y (cm ⁴)	3.46
	W_x (cm ⁴)	0.48
	W_y (cm ⁴)	1.39
Dužina isporuke	mm	6500

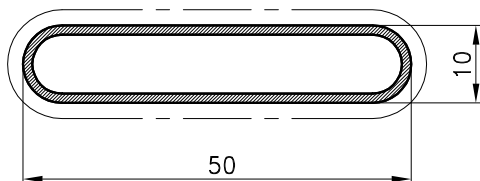

Profil		
Art.-Br.	F-0187/A	
Težina	kg/m	0.349
Opseg	mm	111
Moment inercije	I_x (cm ⁴)	0.21
	I_y (cm ⁴)	3.01
	W_x (cm ⁴)	0.43
	W_y (cm ⁴)	1.20
Dužina isporuke	mm	6500

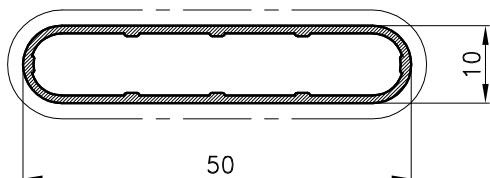

Profil		
Art.-Br.	F-0187/L	
Težina	kg/m	0.307
Opseg	mm	111
Moment inercije	I_x (cm ⁴)	0.20
	I_y (cm ⁴)	2.66
	W_x (cm ⁴)	0.39
	W_y (cm ⁴)	1.07
Dužina isporuke	mm	6500

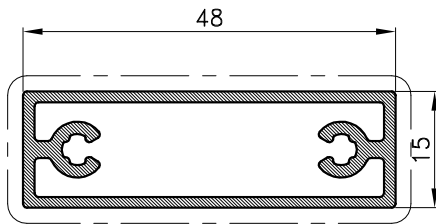

Profil		
Art.-Br.	F-1541	
Težina	kg/m	0.618
Opseg	mm	186
Moment inercije	I _x (cm ⁴)	6.49
	I _y (cm ⁴)	0.69
	W _x (cm ⁴)	2.70
	W _y (cm ⁴)	0.92
Dužina isporuke	mm	6500

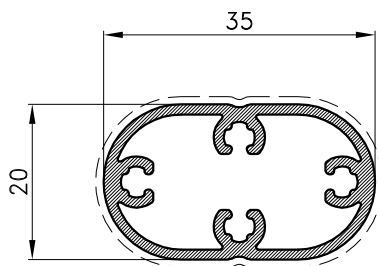

Profil		
Art.-Br.	F-1849	
Težina	kg/m	0.5
Opseg	mm	93.1
Moment inercije	I _x (cm ⁴)	0.83
	I _y (cm ⁴)	2.22
	W _x (cm ⁴)	0.83
	W _y (cm ⁴)	1.27
L	mm	6500

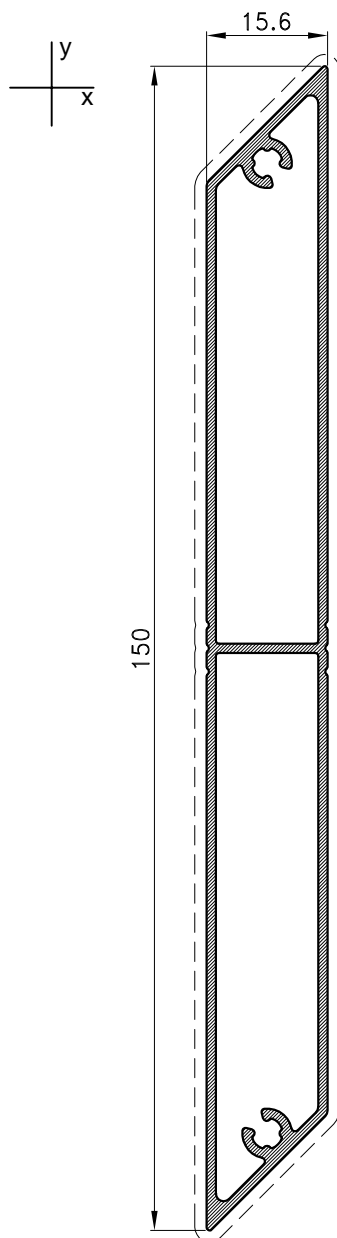

Profil		
Art.-Br.	F-1845	
Težina	kg/m	1.1313
Opseg	mm	314.32
Moment inercije	I_x (cm ⁴)	85.28
	I_y (cm ⁴)	1.79
	W_x (cm ⁴)	11.37
	W_y (cm ⁴)	2.29
Dužina isporuke	mm	6500

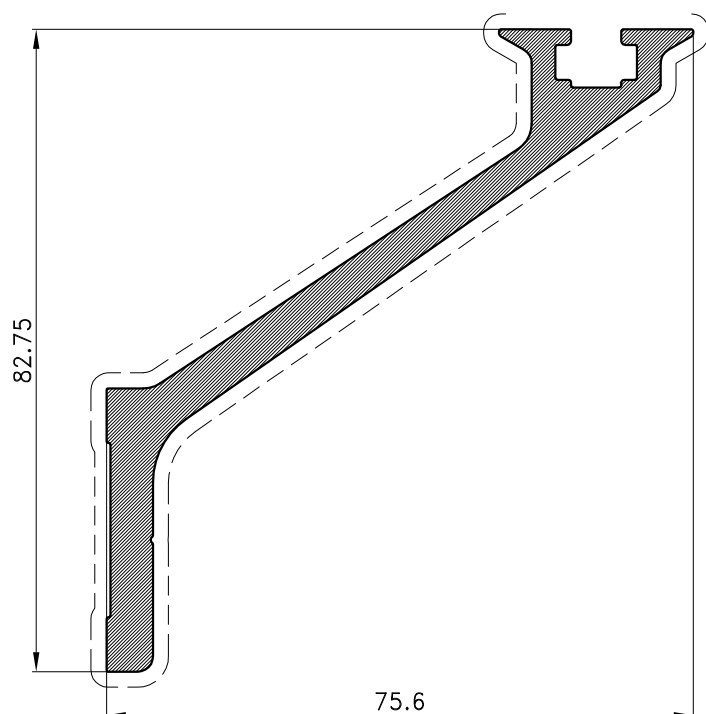

Profil		
Art.-Br.	F-1827	
Težina	kg/m	1.8277
Opseg	mm	287.16
Moment inercije	I_x (cm ⁴)	36.21
	I_y (cm ⁴)	38.89
	W_x (cm ⁴)	7.87
	W_y (cm ⁴)	8.41
Dužina isporuke	mm	6500

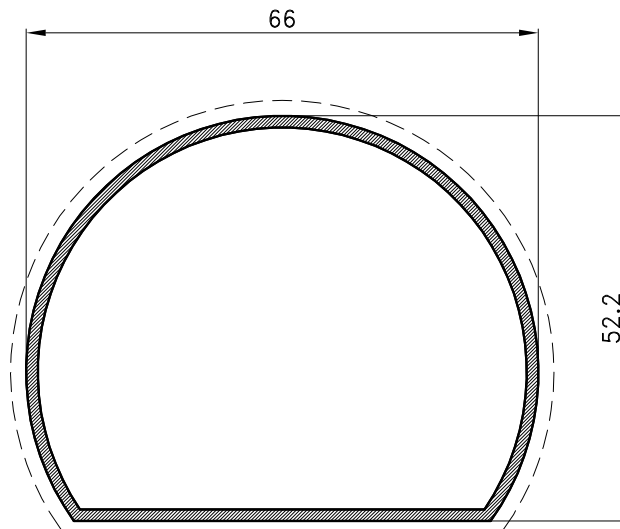

Profil		
Art.-Br.	F-1191	
Težina	kg/m	0.784
Opseg	mm	198.34
Moment inercije	I _x (cm ⁴)	10.90
	I _y (cm ⁴)	15.18
	W _x (cm ⁴)	3.73
	W _y (cm ⁴)	4.60
Dužina isporuke	mm	6500

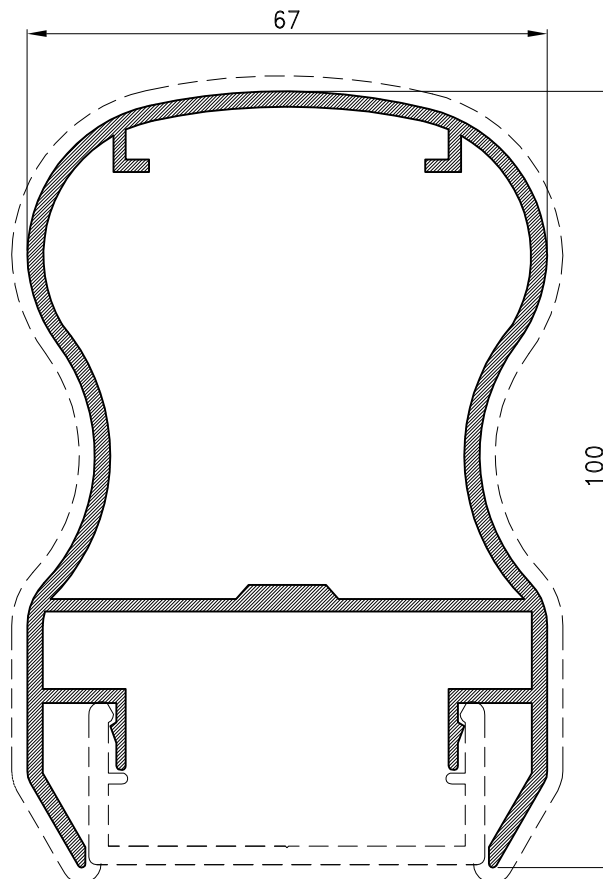

Profil		
Art.-Br.	F-0673	
Težina	kg/m	1.925
Opseg	mm	469
Moment inercije	I _x (cm ⁴)	66.23
	I _y (cm ⁴)	44.90
	W _x (cm ⁴)	12.74
	W _y (cm ⁴)	13.39
Dužina isporuke	mm	6500

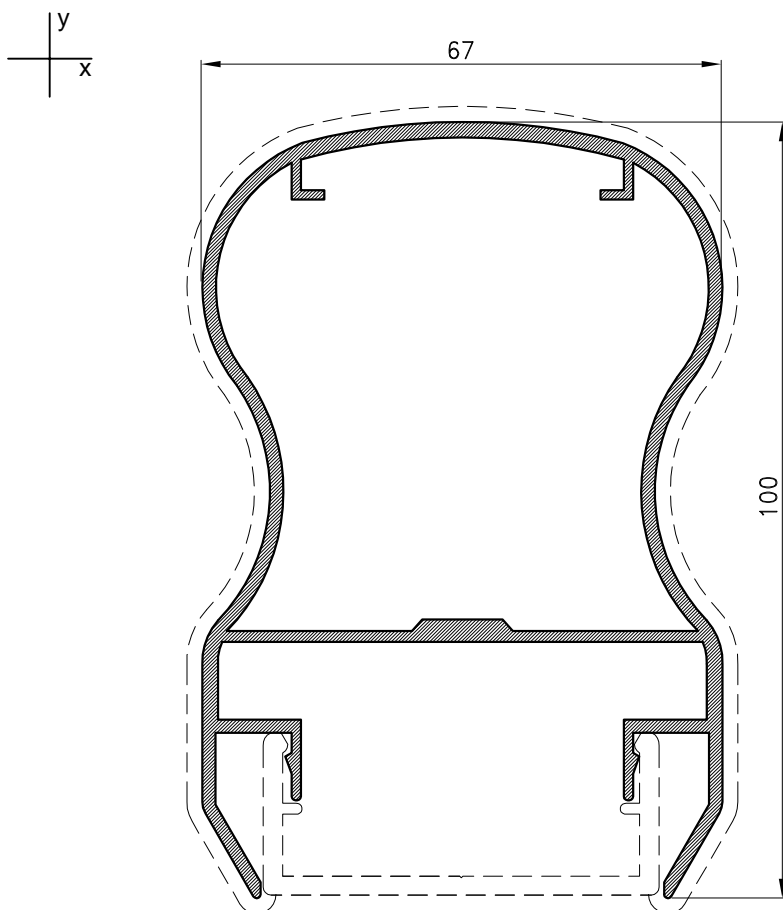

Profil		
Art.-Br.	F-0673/A	
Težina	kg/m	1.735
Opseg	mm	470
Moment inercije	I_x (cm ⁴)	60.76
	I_y (cm ⁴)	40.48
	W_x (cm ⁴)	11.66
	W_y (cm ⁴)	12.08
Dužina isporuke	mm	6500

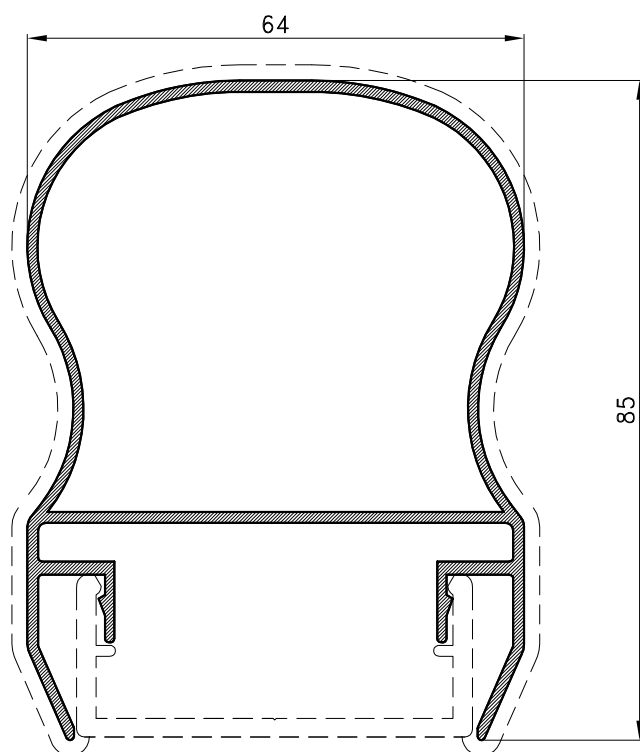

Profil		
Art.-Br.	F-1334	
Težina	kg/m	1.185
Opseg	mm	414.53
Moment inercije	I_x (cm ⁴)	28.66
	I_y (cm ⁴)	26.24
	W_x (cm ⁴)	6.70
	W_y (cm ⁴)	8.20
Dužina isporuke	mm	6500

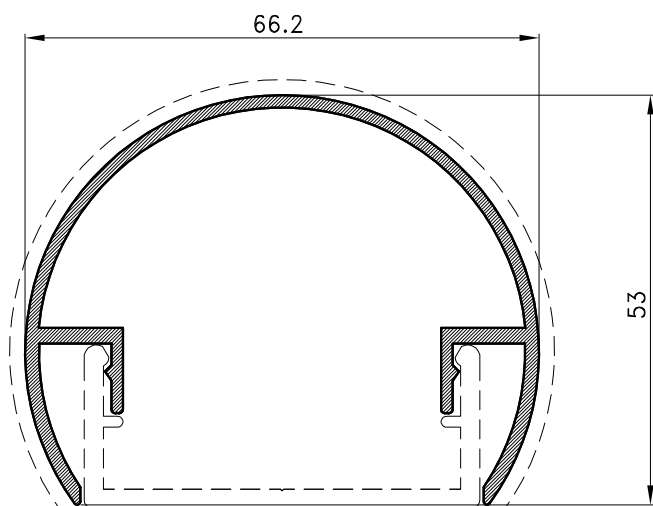

Profil		
Art.-Br.	F-0621	
Težina	kg/m	0.831
Opseg	mm	367
Moment inercije	I_x (cm ⁴)	7.21
	I_y (cm ⁴)	19.42
	W_x (cm ⁴)	2.55
	W_y (cm ⁴)	5.87
Dužina isporuke	mm	6500

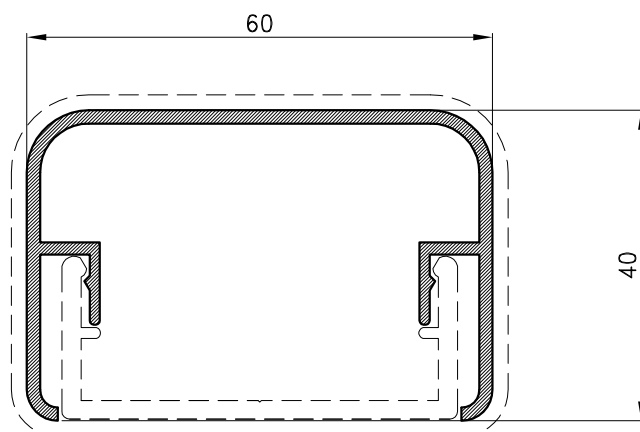

Profil		
Art.-Br.	F-0689	
Težina	kg/m	0.74
Opseg	mm	335
Moment inercije	I_x (cm ⁴)	4.20
	I_y (cm ⁴)	15.94
	W_x (cm ⁴)	1.64
	W_y (cm ⁴)	5.31
Dužina isporuke	mm	6500

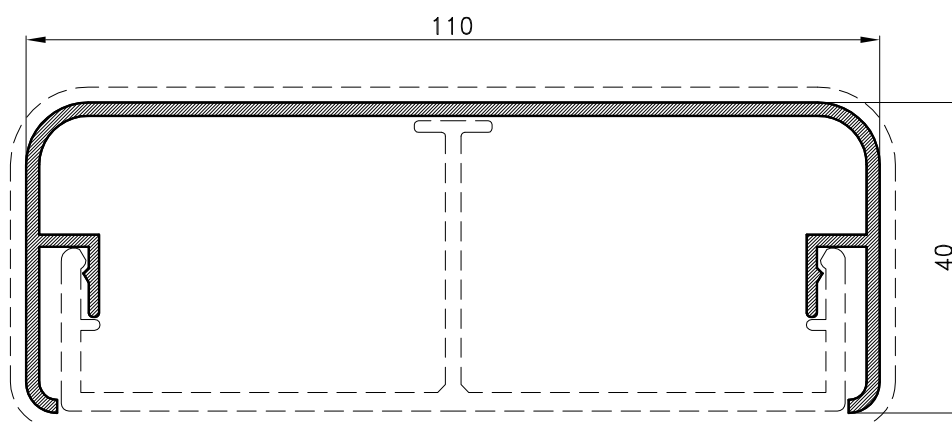

Profil		
Art.-Br.	F-1096	
Težina	kg/m	0.970
Opseg	mm	435
Moment inercije	I_x (cm ⁴)	5.37
	I_y (cm ⁴)	65.89
	W_x (cm ⁴)	1.86
	W_y (cm ⁴)	11.98
Dužina isporuke	mm	6500

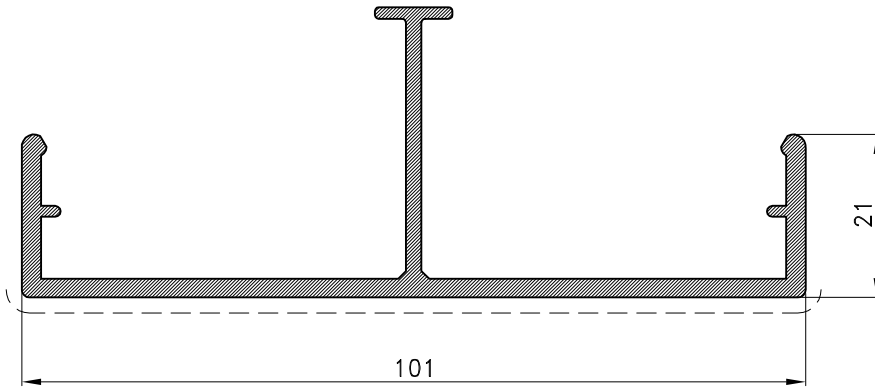

Profil		
Art.-Br.	F-1097	
Težina	kg/m	1.148
Opseg	mm	372
Moment inercije	I_x (cm ⁴)	4.21
	I_y (cm ⁴)	44.62
	W_x (cm ⁴)	1.42
	W_y (cm ⁴)	8.83
Dužina isporuke	mm	6500

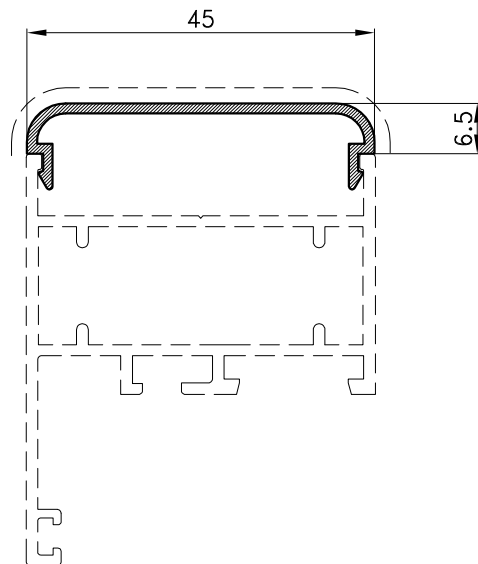

Profil		
Art.-Br.	M45-756	
Težina	kg/m	0.225
Opseg	mm	132
Moment inercije	I_x (cm ⁴)	0.08
	I_y (cm ⁴)	2.02
	W_x (cm ⁴)	0.09
	W_y (cm ⁴)	0.90
Dužina isporuke	mm	6500

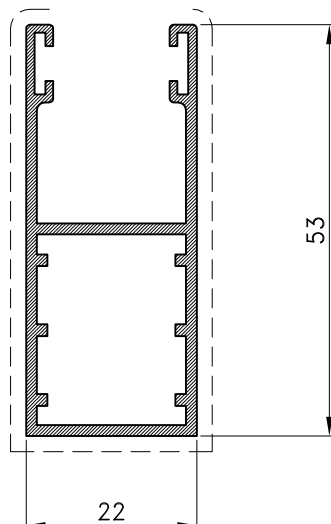

Profil		
Art.-Br.	F-0608	
Težina	kg/m	0.607
Opseg	mm	231
Moment inercije	I_x (cm ⁴)	5.86
	I_y (cm ⁴)	1.90
	W_x (cm ⁴)	2.00
	W_y (cm ⁴)	1.72
Dužina isporuke	mm	6500

Vezni elementi

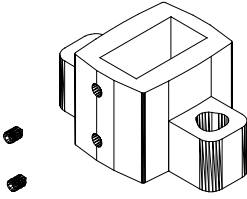
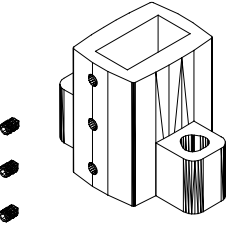
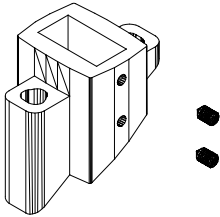
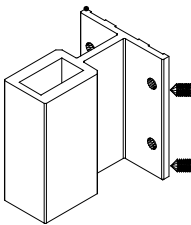
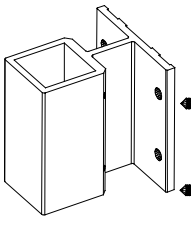
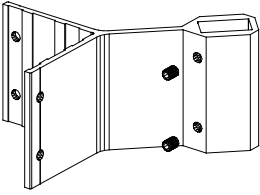
Oznaka	Izgled-presjek	Opis	Materijal	Nap.
521.042		- Stopa ograde; - Stara oznaka: OG-S-01	Al.	
521.043		- Stopa ograde; - Stara oznaka: OG-S-02	Al.	
521.044		- Stopa ograde pod kutem; - Stara oznaka: OG-S-03	Al.	
521.054		- Bočna stopa ograde ; - Stara oznaka: OG-V-07	Al.	
521.126		- Bočna stopa ograde; 2 vijka M6X10 DIN 914	Al.	
521.062		- Bočna stopa ograde ;	Al.	

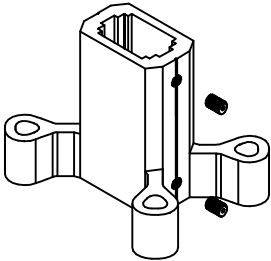
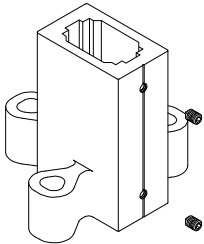
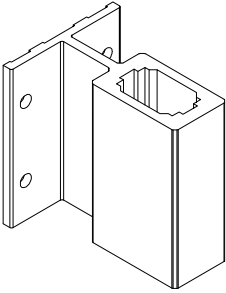
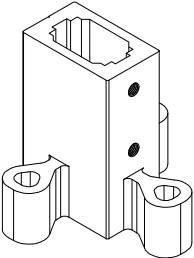
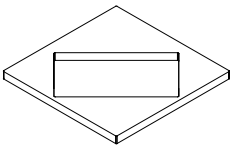
Oznaka	Izgled-presjek	Opis	Materijal	Nap.
521.060		- Stopa ograde;	Al.	
521.266		- Stopa ograde;	Al.	
521.523.01 .02 .03		- Stopa ograde - Radi se iz profila F-1856 - H=100mm	Al	
521.522.01 .02 .03		- Stopa ograde - Radi se iz profila F-1582 - H=100mm	Al	
521.125		- Pločica 52x52x3 za bočnu stopu 521.062	Al.	

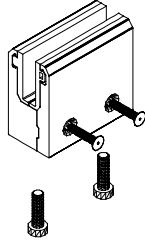
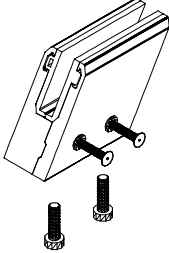
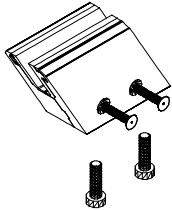
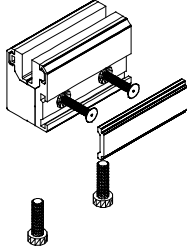
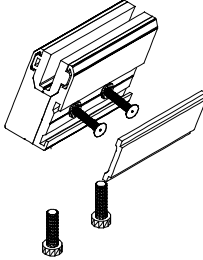
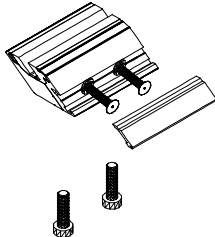
Oznaka	Izgled-presjek	Opis	Materijal	Nap.
521.082		- Držać stakla (staklo 55.2 - ravni)	Al	
521.093		- Držać stakla (staklo 55.2 - kosi D)	Al	
521.096		- Držać stakla (staklo 55.2 - kosi L)	Al	
521.045		- Držać stakla (staklo 44.2 - ravni) -Stara oznaka - DSR-01	Al	
521.046		- Držać stakla (staklo 44.2 - kosi D) -Stara oznaka - DSK-02	Al	
521.131		- Držać stakla (staklo 44.2 - kosi L)	Al	

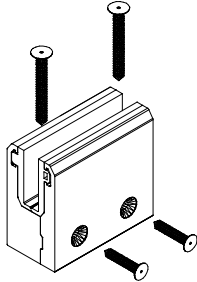
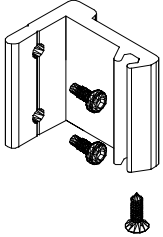
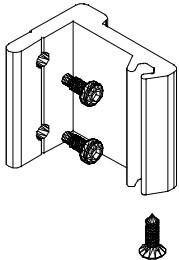
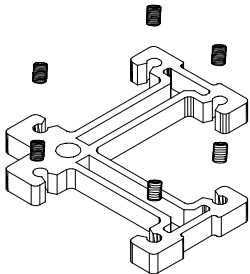
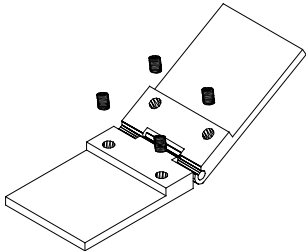
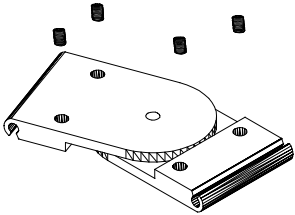
Oznaka	Izgled-presjek	Opis	Materijal	Nap.
521.099		-Bočni držač stakla (staklo 55.2)	Al	
521.047		- Veznik za F-0174 ; - Stara oznaka : 060 814	Al	
521.048		- Veznik za F-0048 ; - Stara oznaka : 060 814/A	Al.	
521.049		- Veznik; - Stara oznaka: OG-V-01	Al.	
521.050		- Veznik pod kutem; - Stara oznaka: OG-V-02	Al	
521.051		- Veznik pod kutem; - Stara oznaka: OG-V-03	Al	

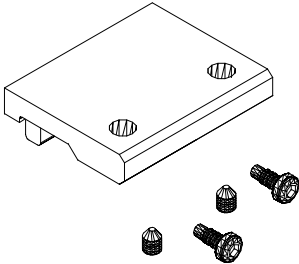
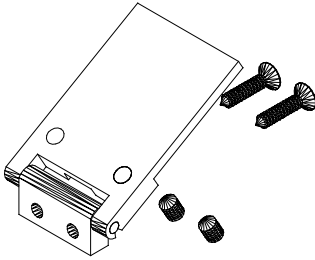
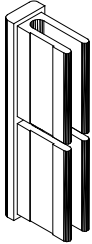
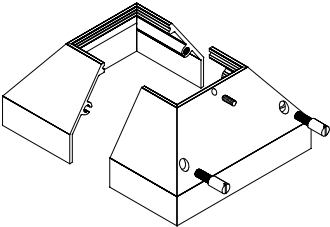
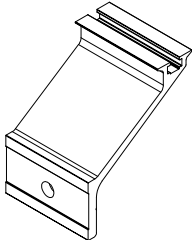
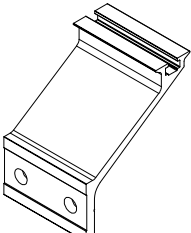
Oznaka	Izgled-presjek	Opis	Materijal	Nap.
521.052		- Veznik pod 90° - Stara oznaka: OG-V-04	Al	
521.053		- Veznik pod kutem; - Stara oznaka: OG-V-05	Al	
391.045		- Bočni poklopac za profil F-0062 - Stara oznaka: DE-0340	Al	
392.001.01 .02 .03		- Maska stubića al. ograde - Oznaka proizvođača 700.300.310 700.300.305 ; 700.300.313 - Boje: 01- bijela; 02 - siva; 03 - crna	Al.	
521.512.01 .02 .03		- držač profila podrukohvata - radi se iz profila F-1827 - koristi se vijak-tipla	Al.	
521.513.01 .02 .03		- držač profila podrukohvata - radi se iz profila F-1827 - koristi se vijak-tipla	Al.	

PVC komponente

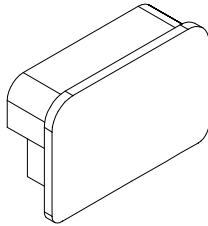
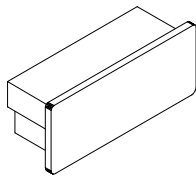
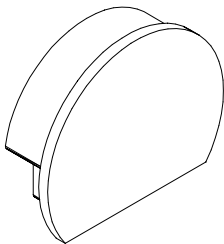
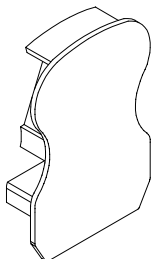
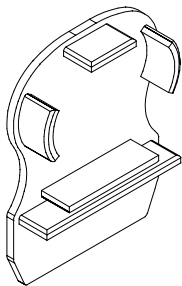
Oznaka	Izgled-presjek	Opis	Materijal	Nap.
373.007.01 02 03		- Bočni čep za profil F-0689 - Stara oznaka: RA 450 01-bijela 02-siva 03-crna	PVC	
373.008.01 02 03		- Bočni čep za profil F-0620 - Stara oznaka: RA 452 01-bijela 02-siva 03-crna	PVC	
374.036.01 02 03		- Bočni čep za profil F-0621 - Stara oznaka: RA 723 01-bijela 02-siva 03-crna	PVC	
373.009.01 02 03		- Stara oznaka: RA 752 - Bočni čep za profil F-0673 01-bijela 02-siva 03-crna	PVC	
373.030.01 02 03		- Bočni čep za profil F-1334 01-bijela 02-siva 03-crna	PVC	

Presjeci

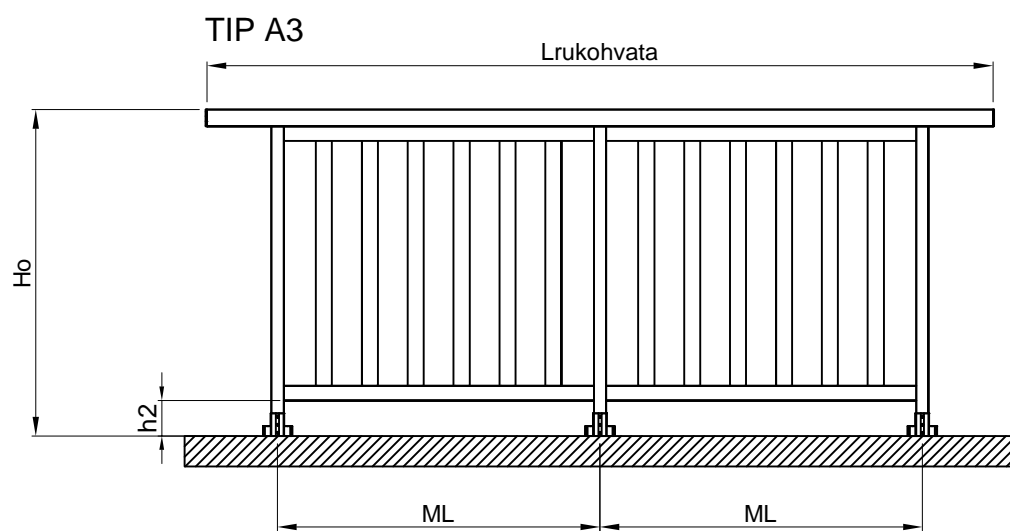
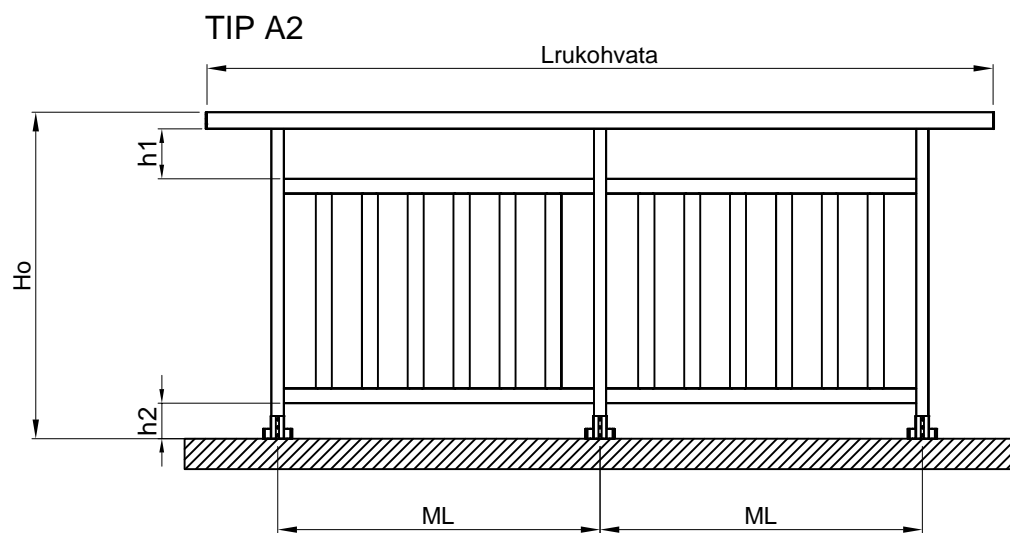
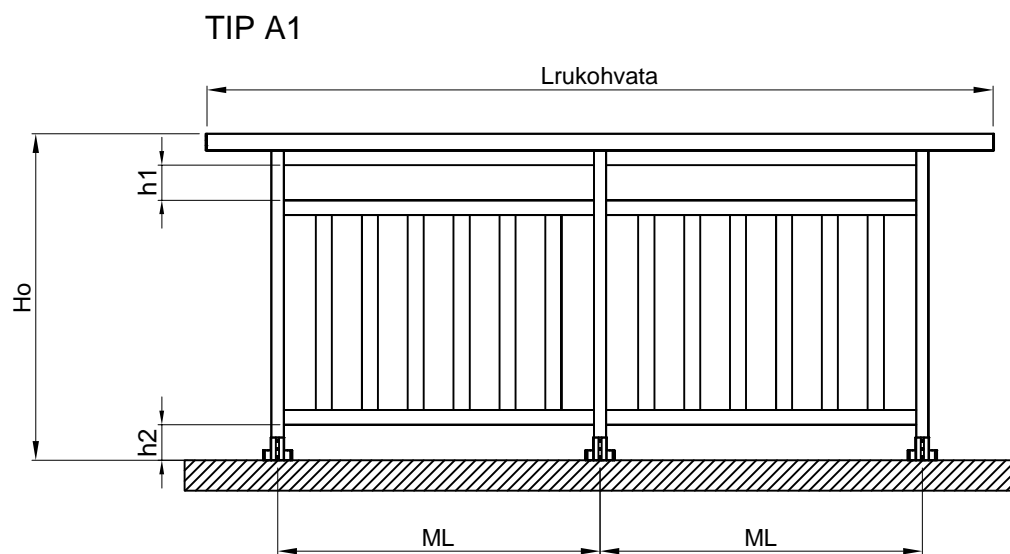

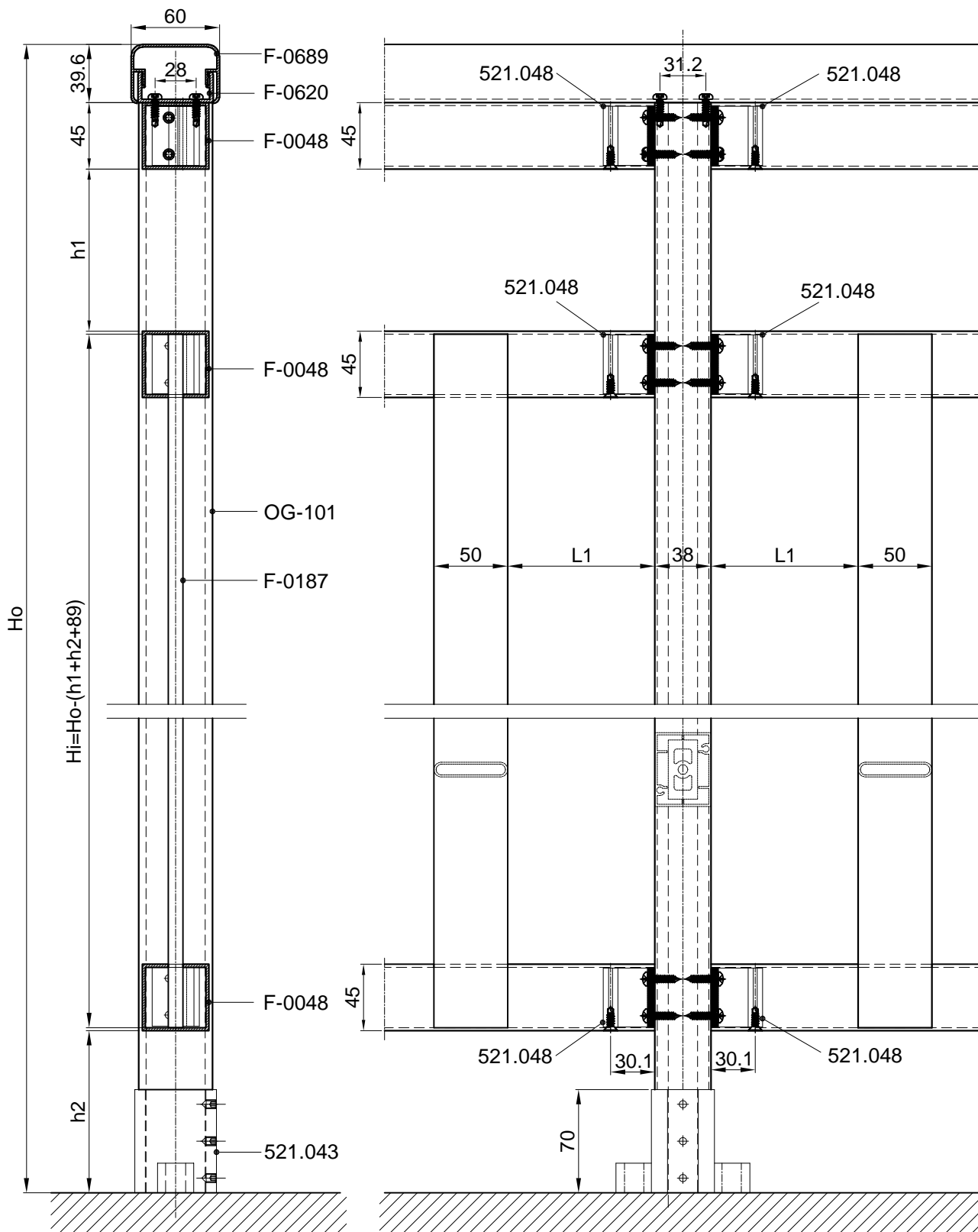
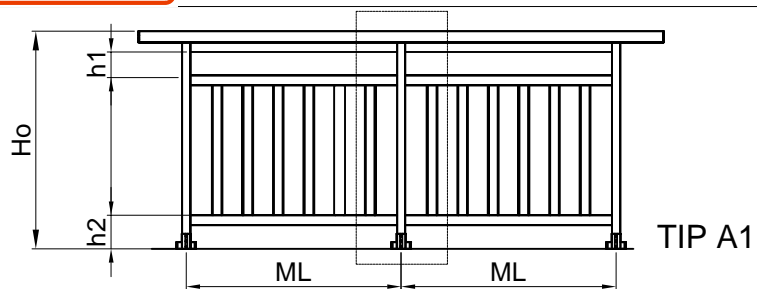

M 1:4

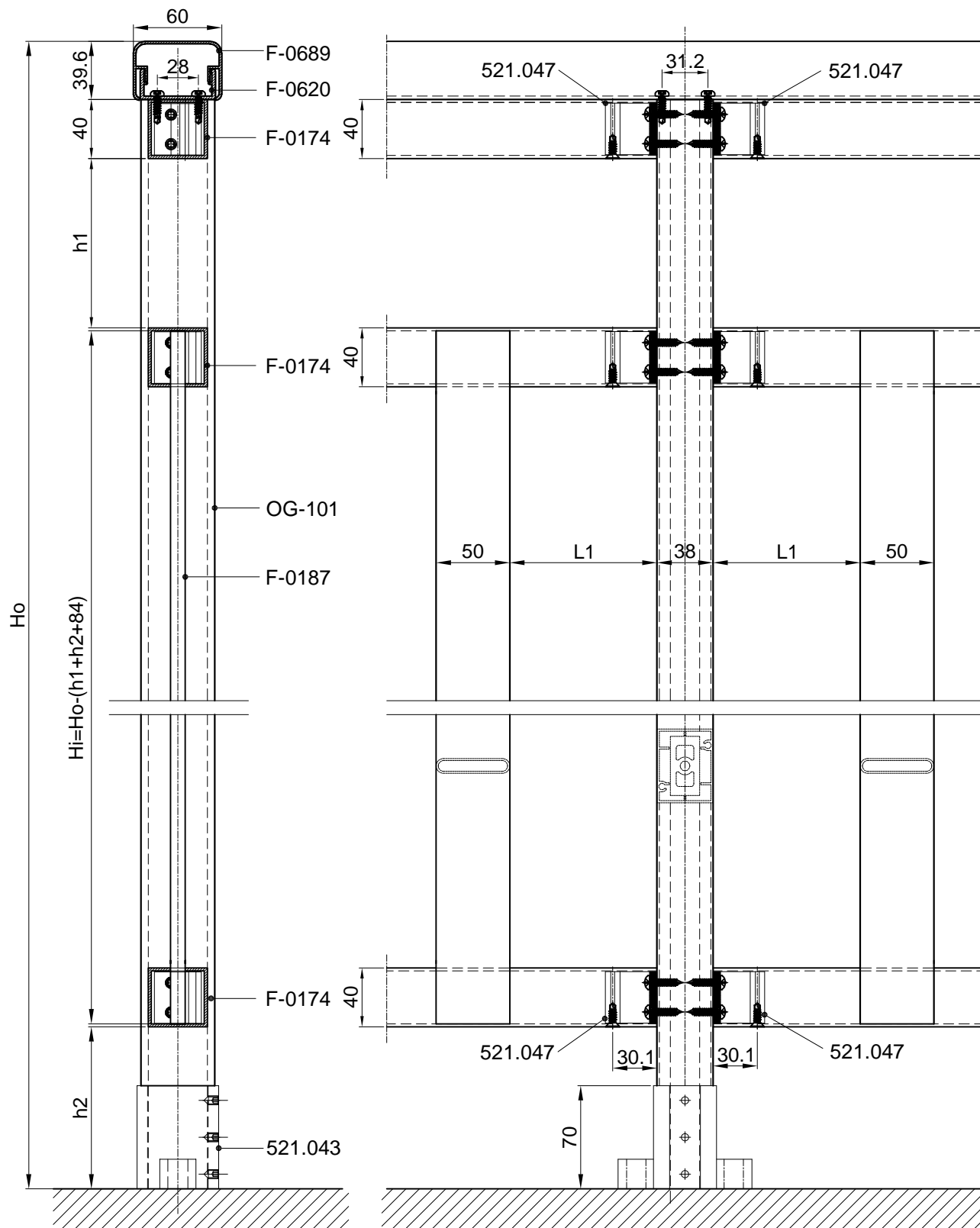
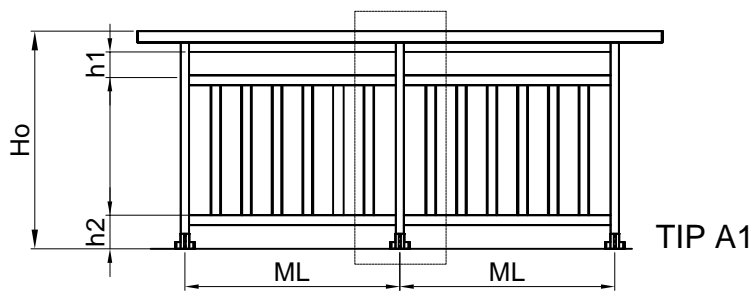

M 1:4

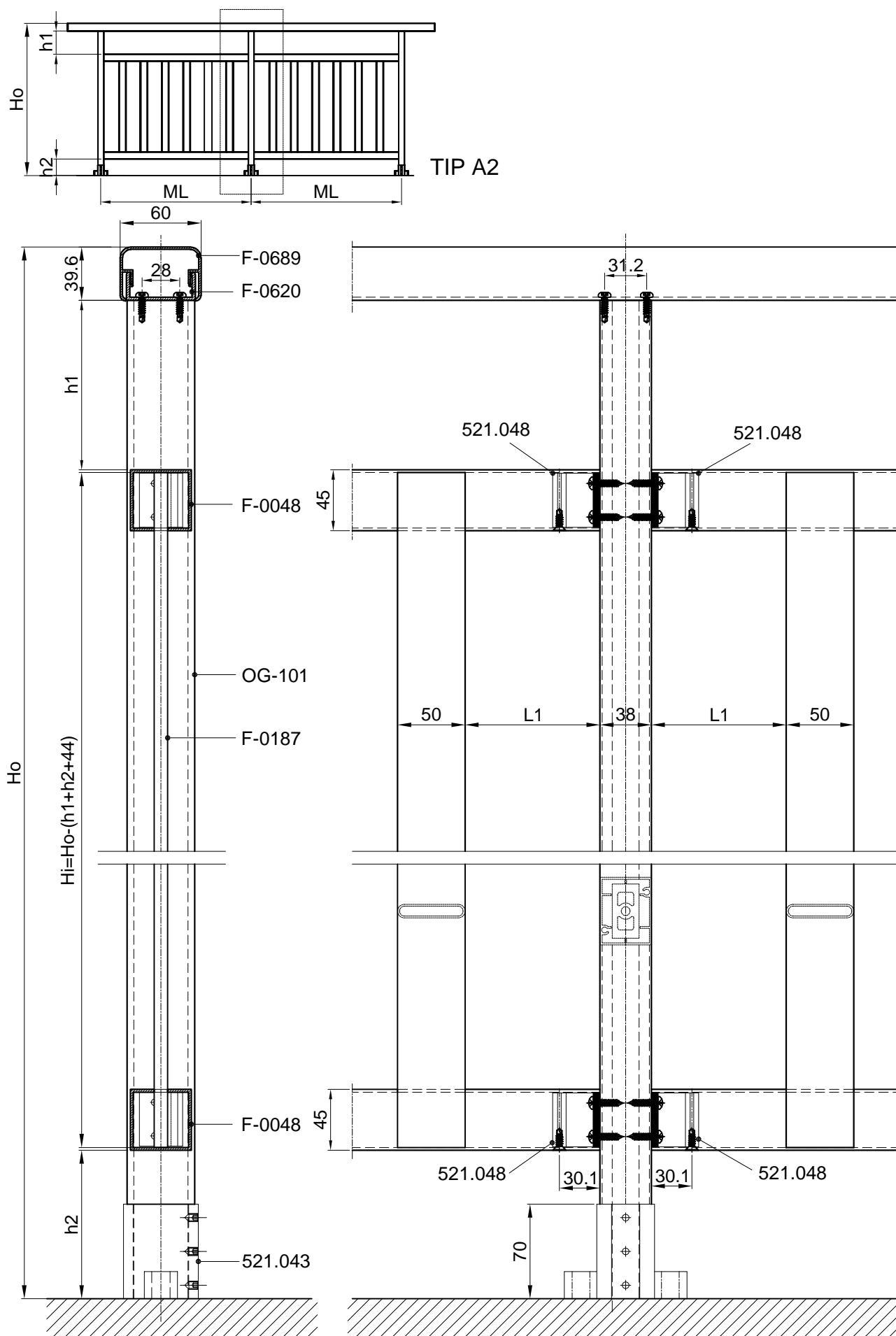

M 1:4

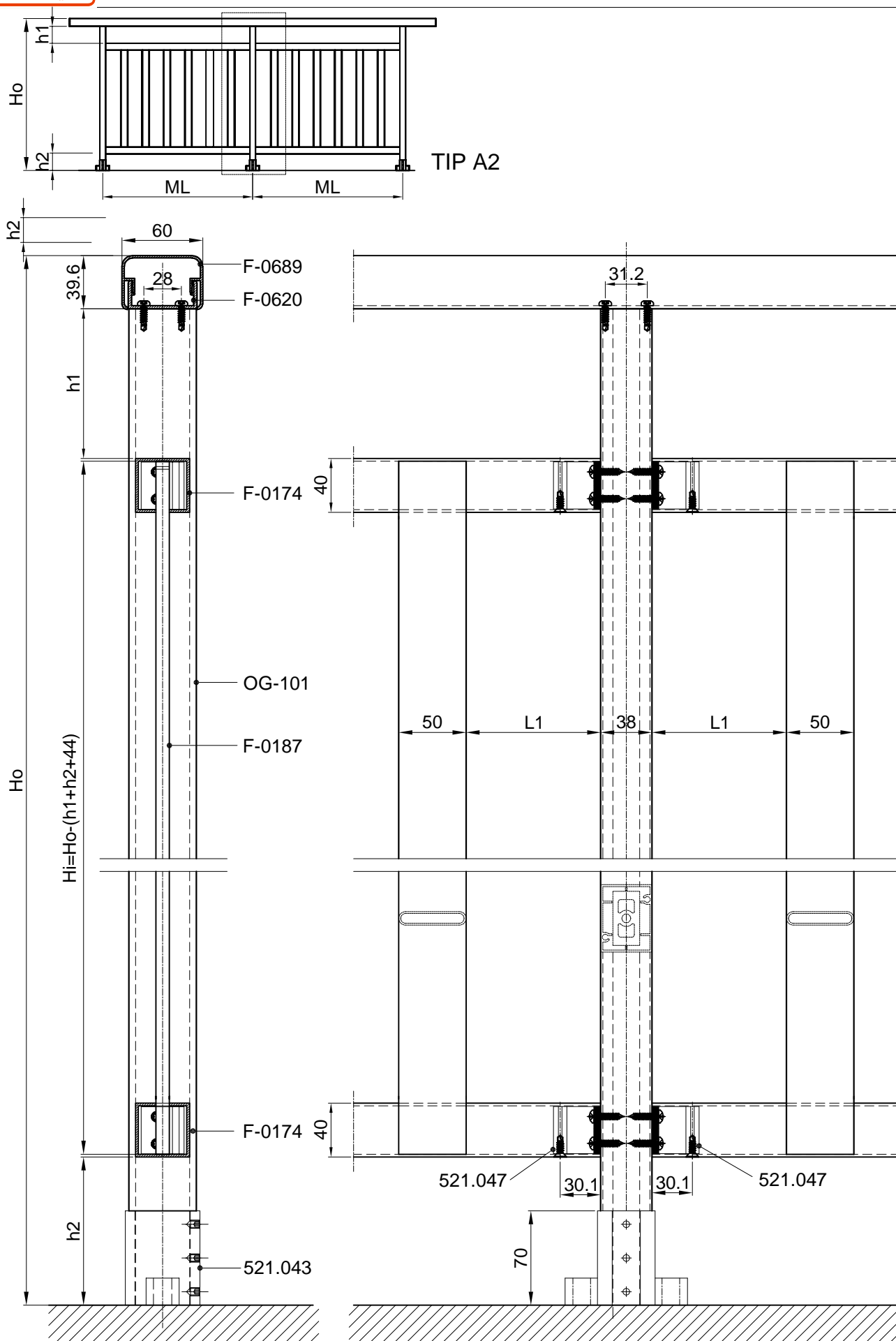

M 1:4

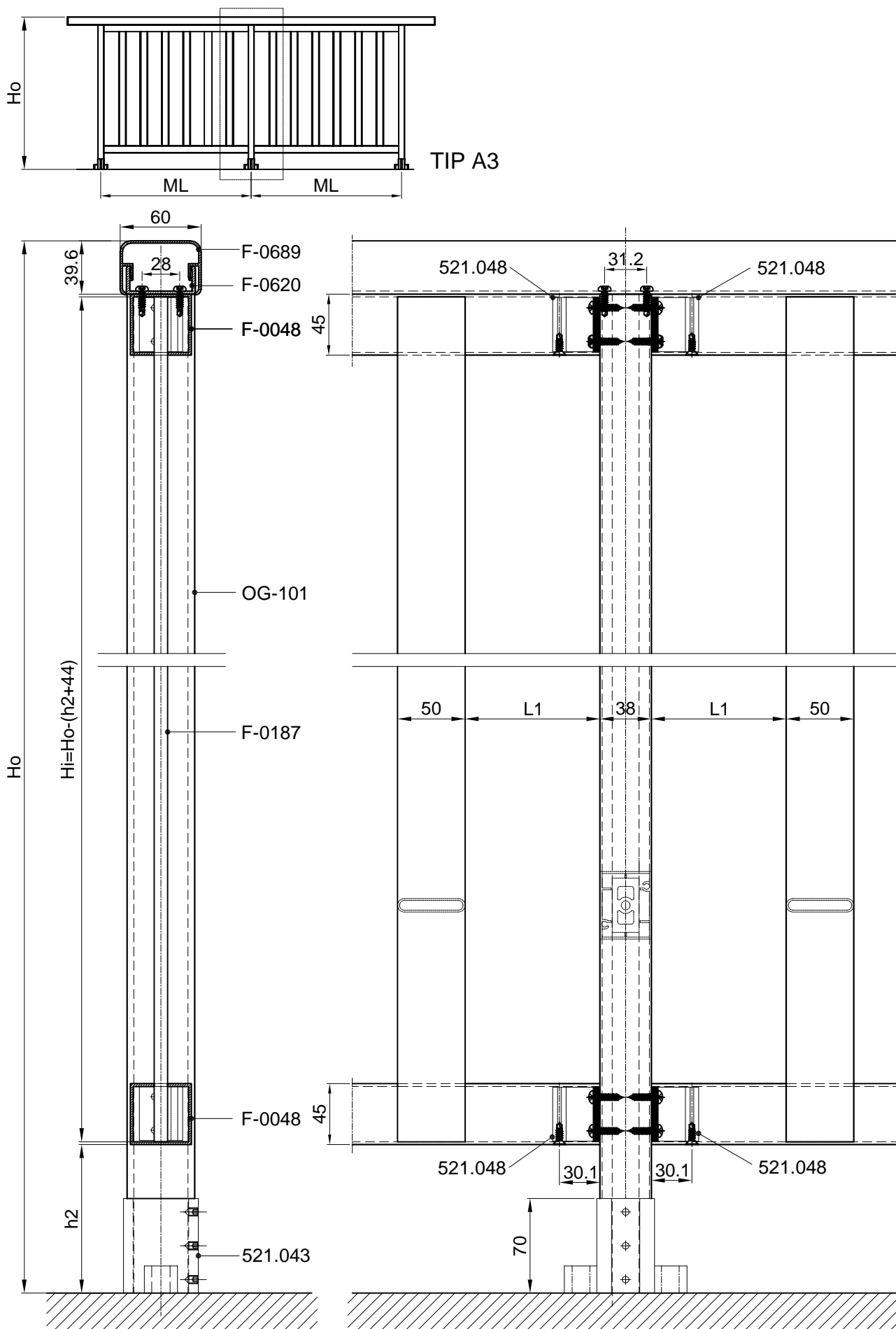

M 1:4

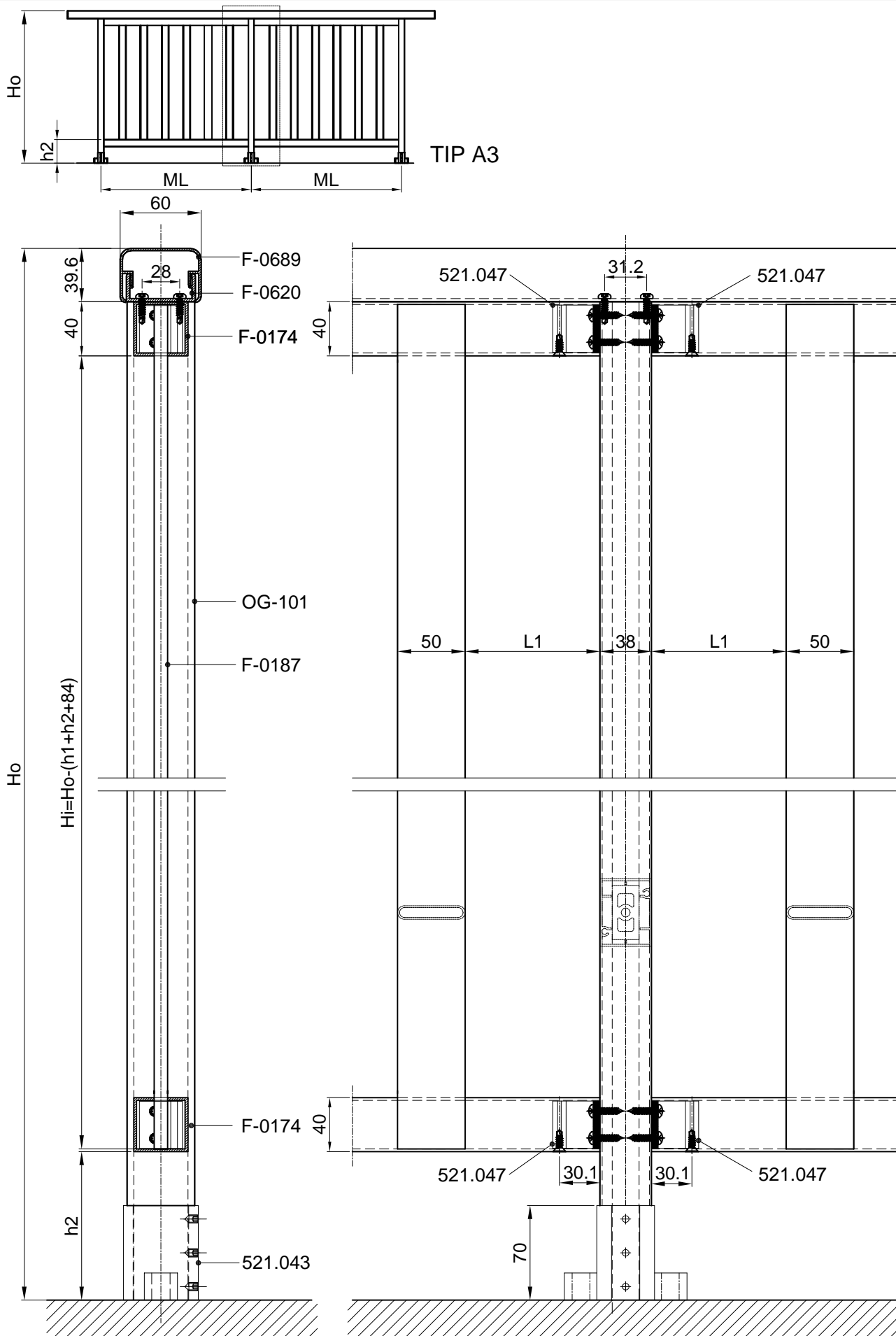

M 1:4

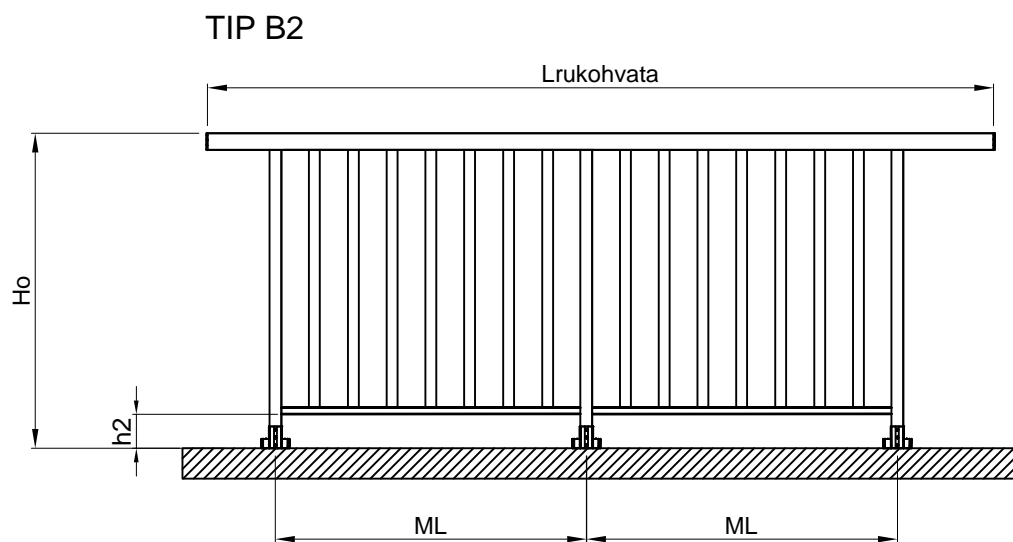
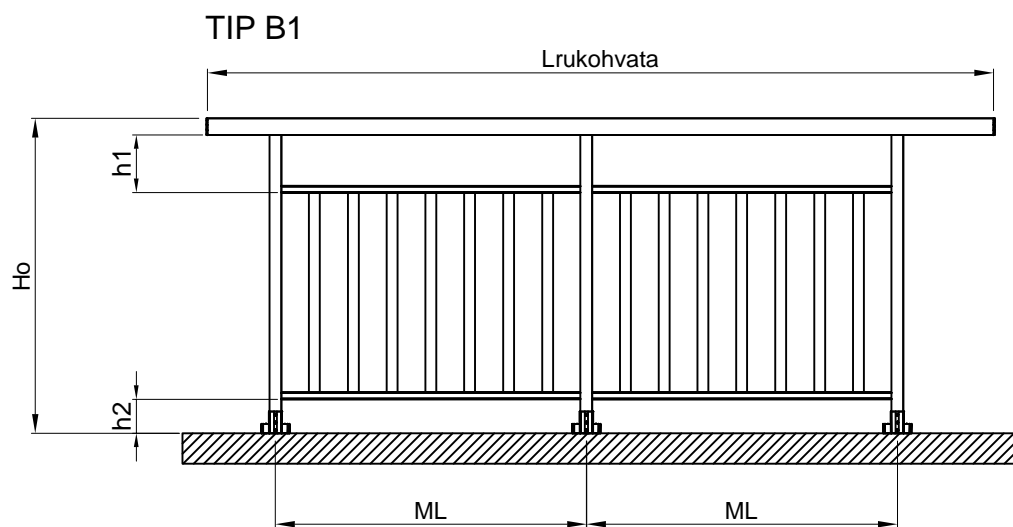

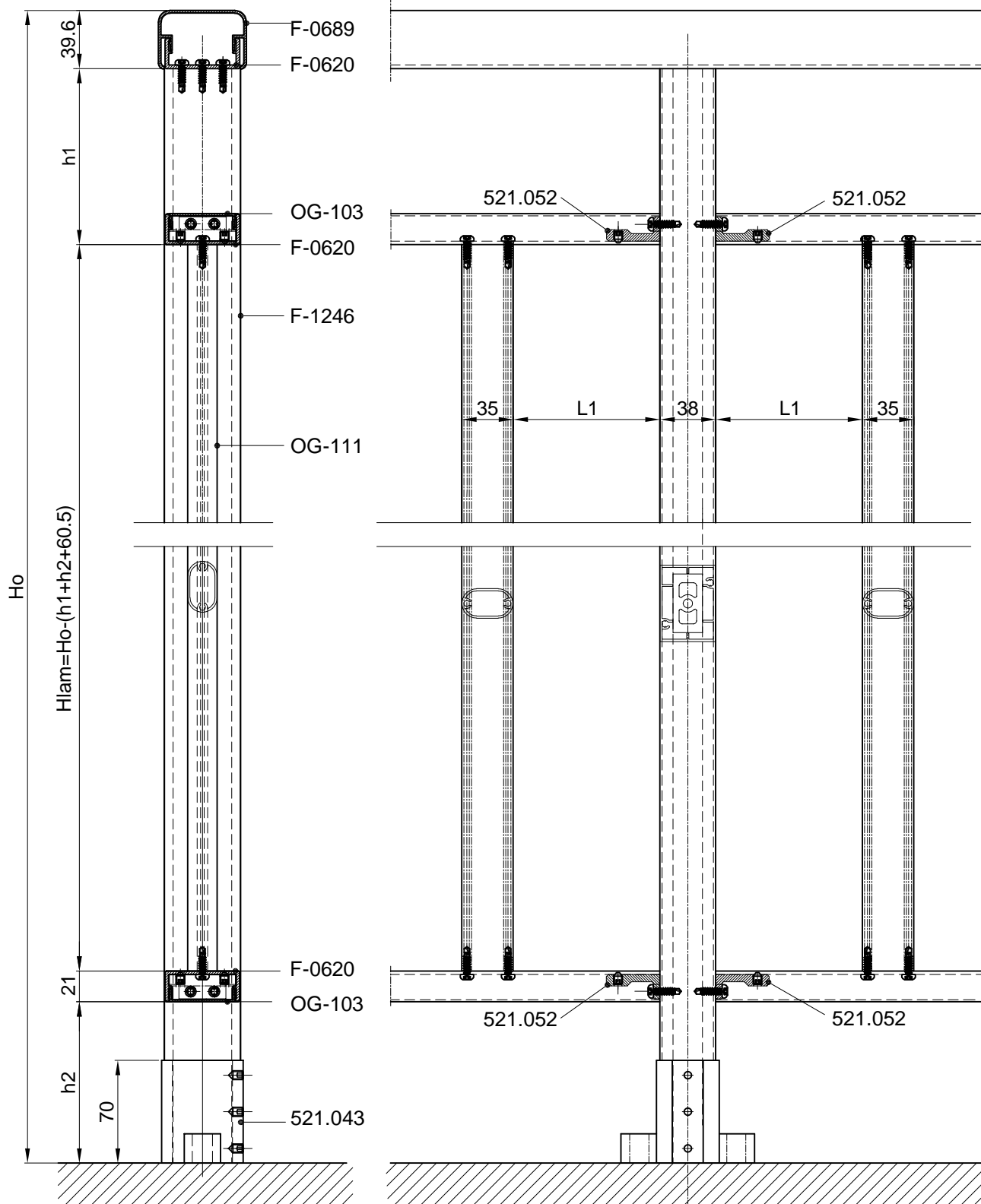
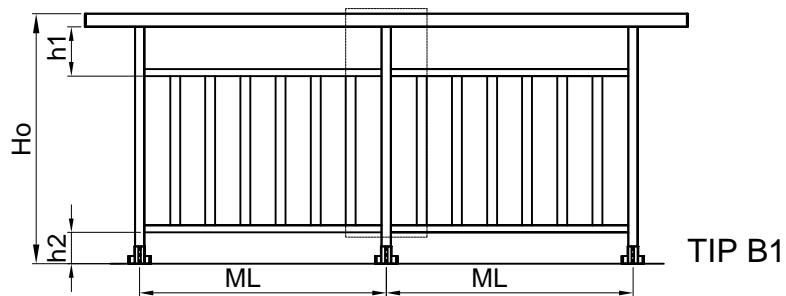

M 1:4

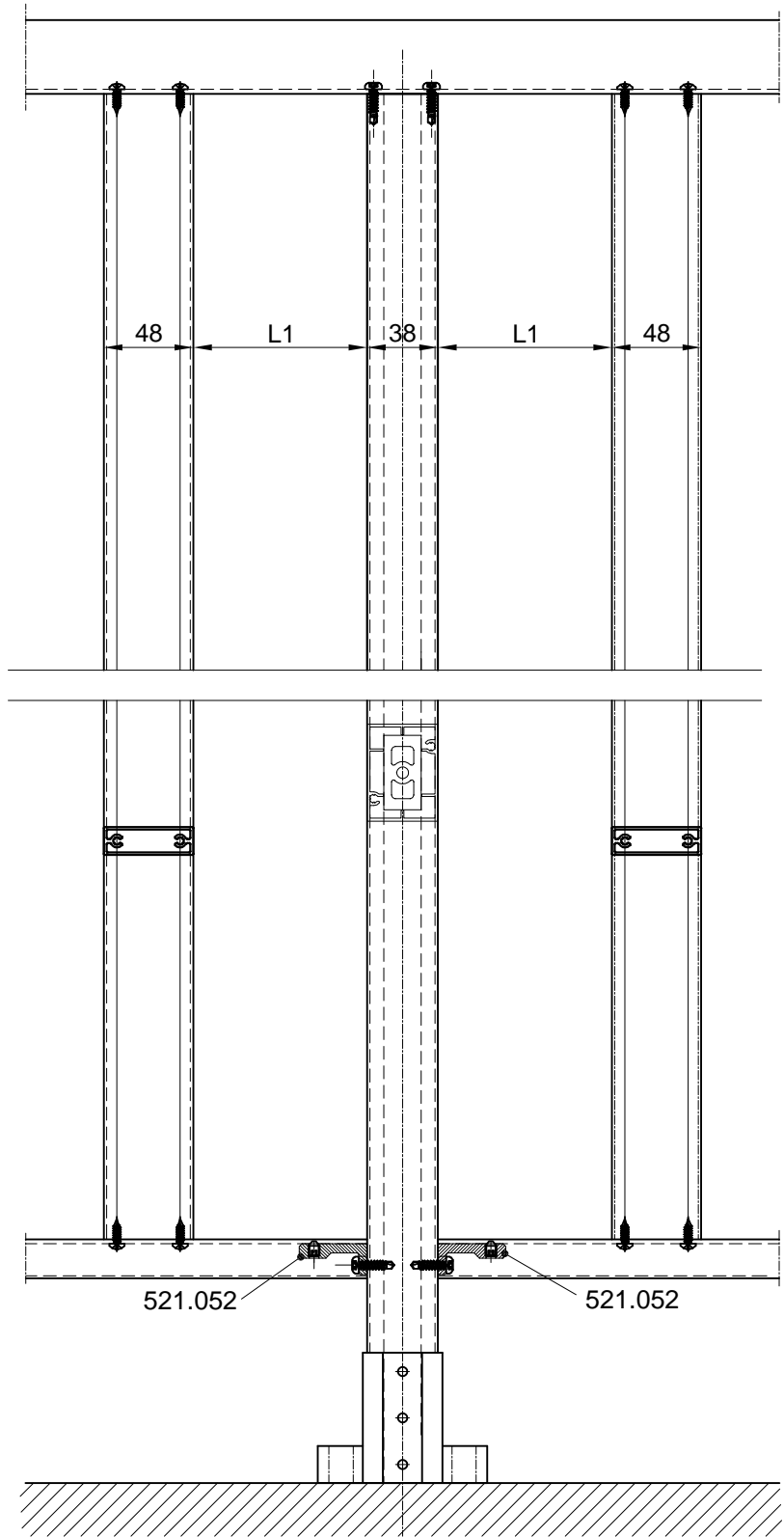
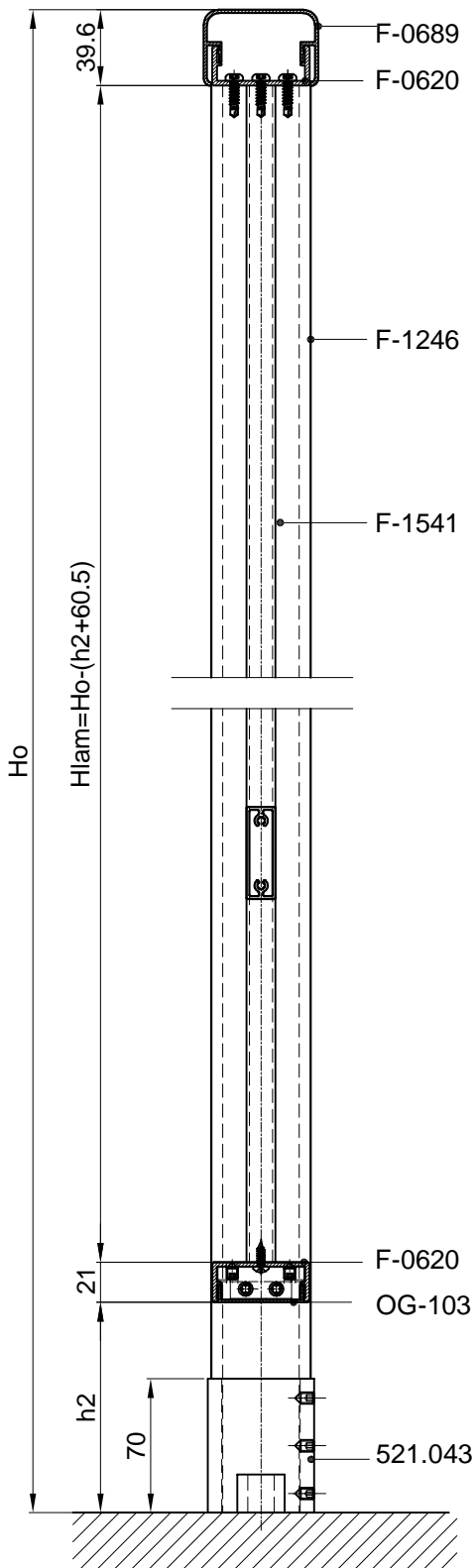
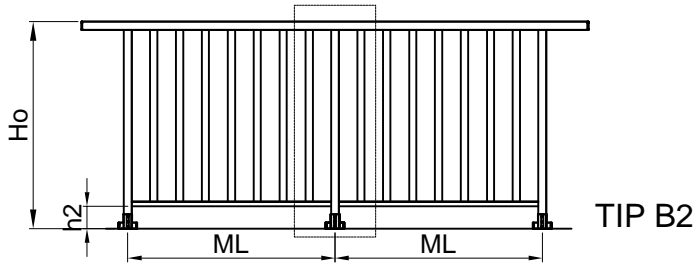

M 1:4

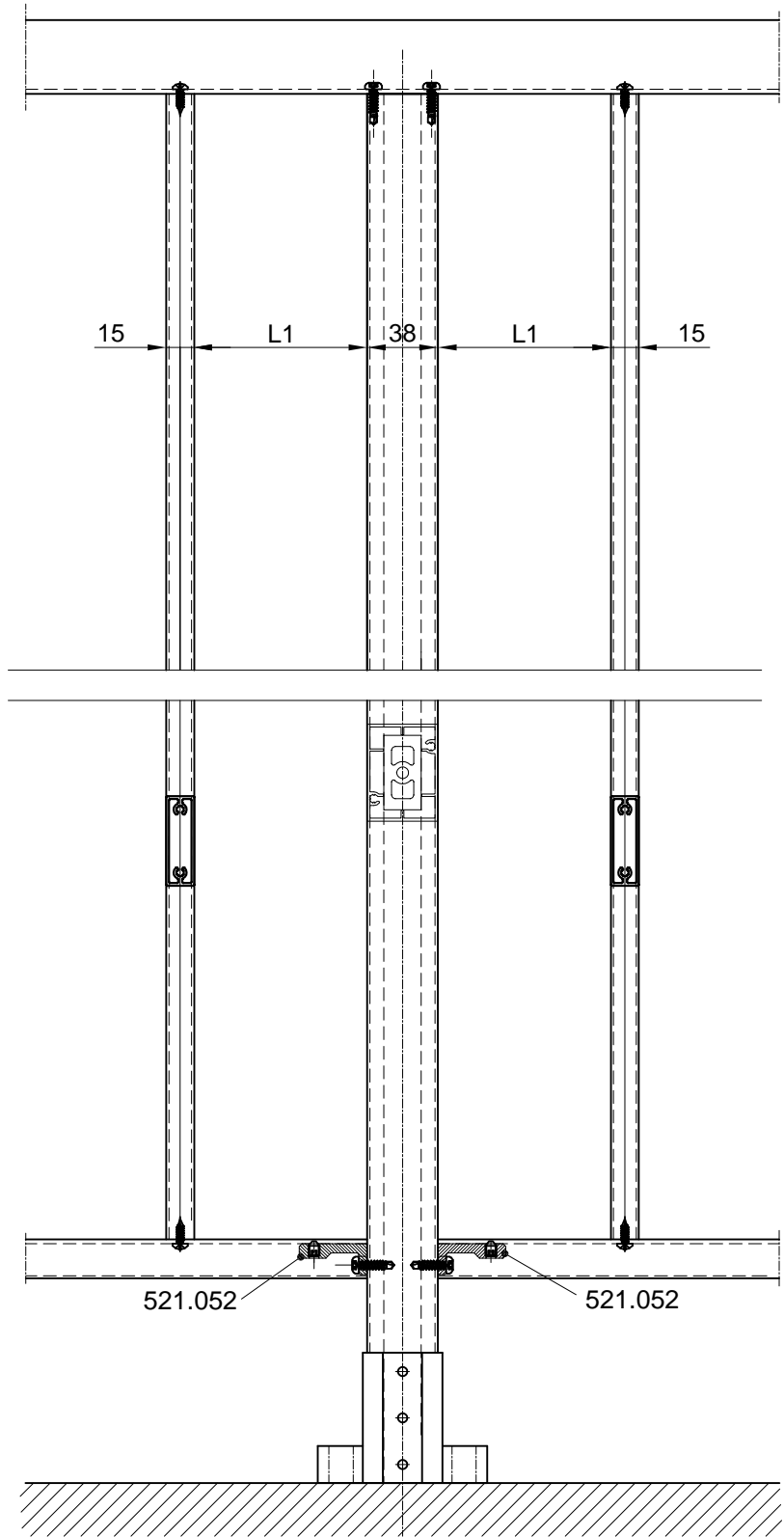
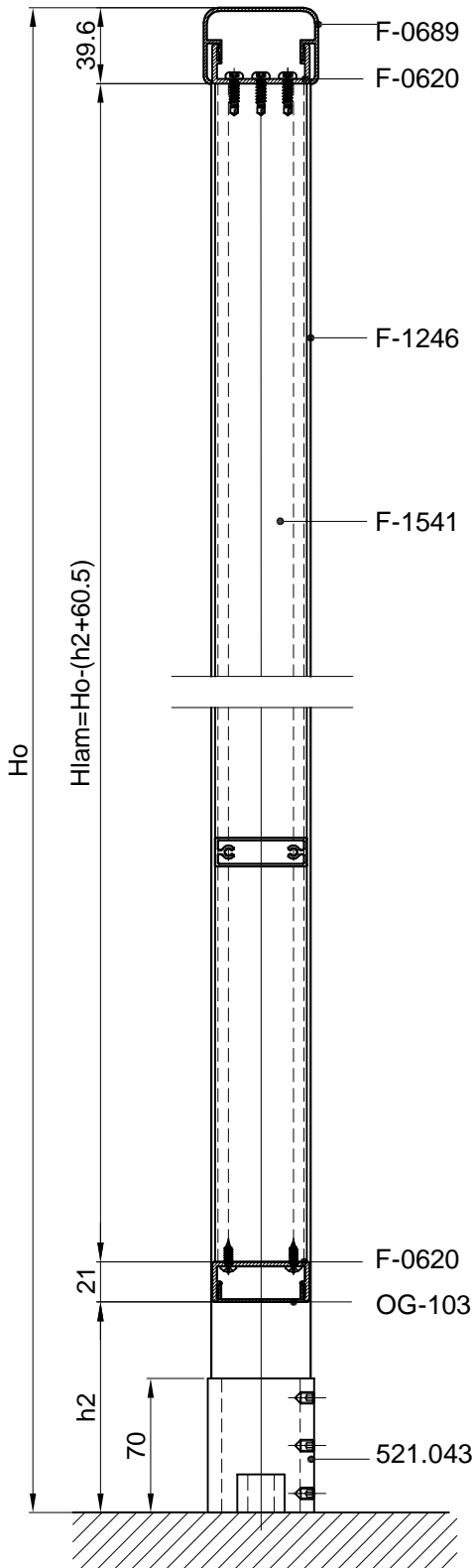
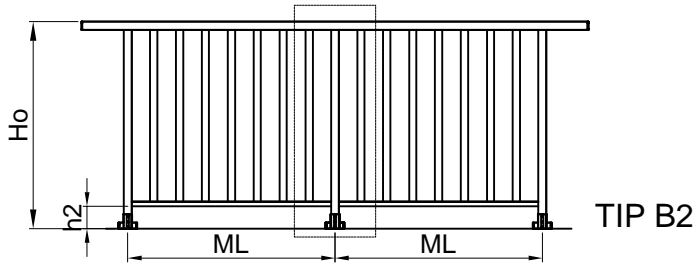

M 1:4

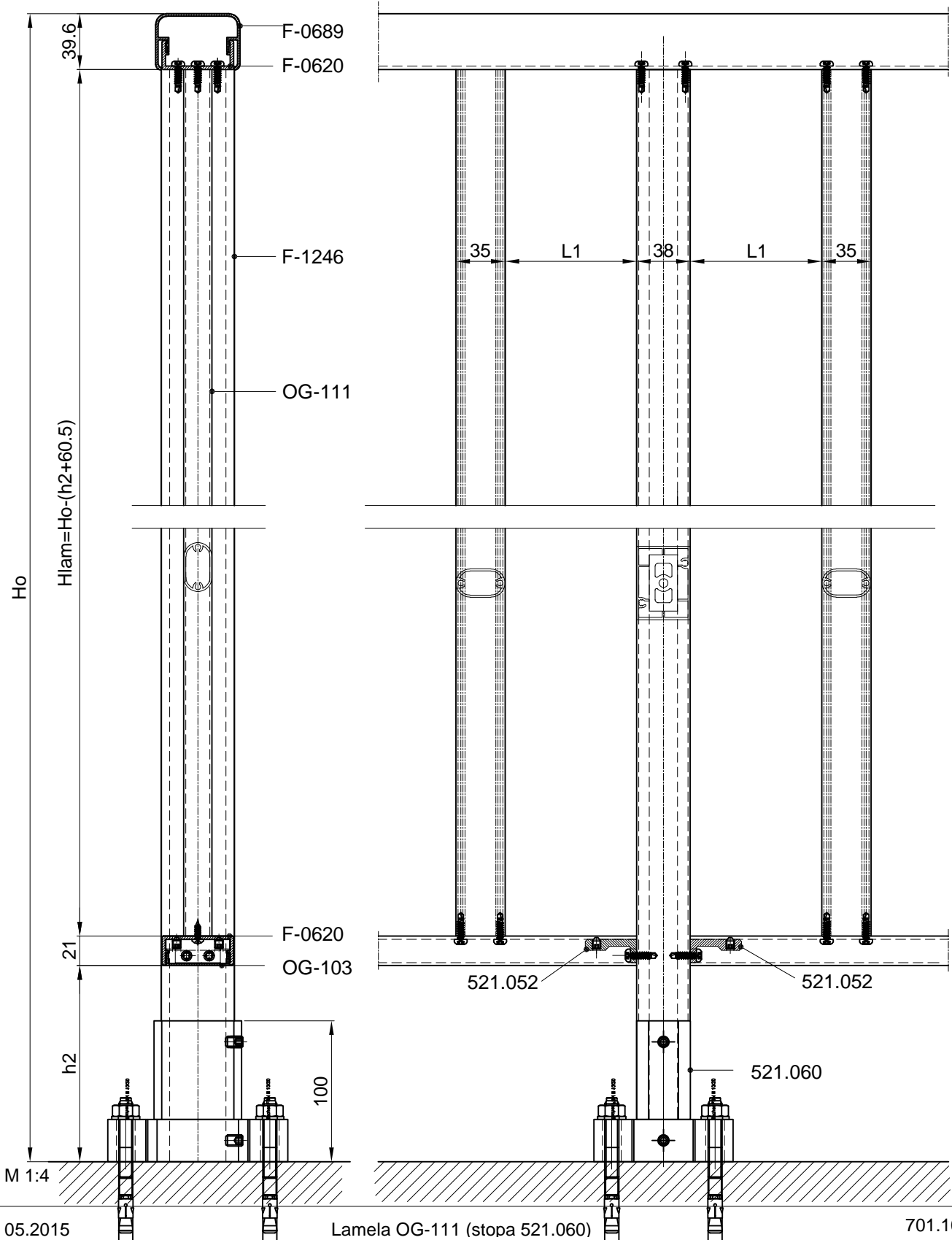
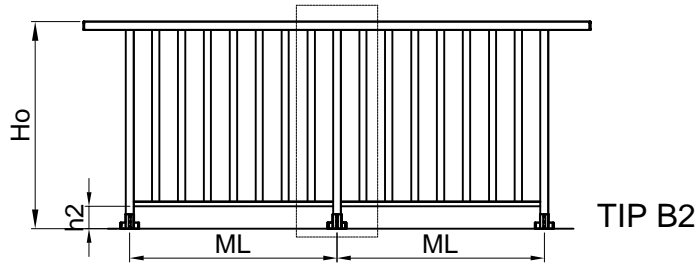

Držač stakla 521.082 /za staklo 55.2

TIP C1

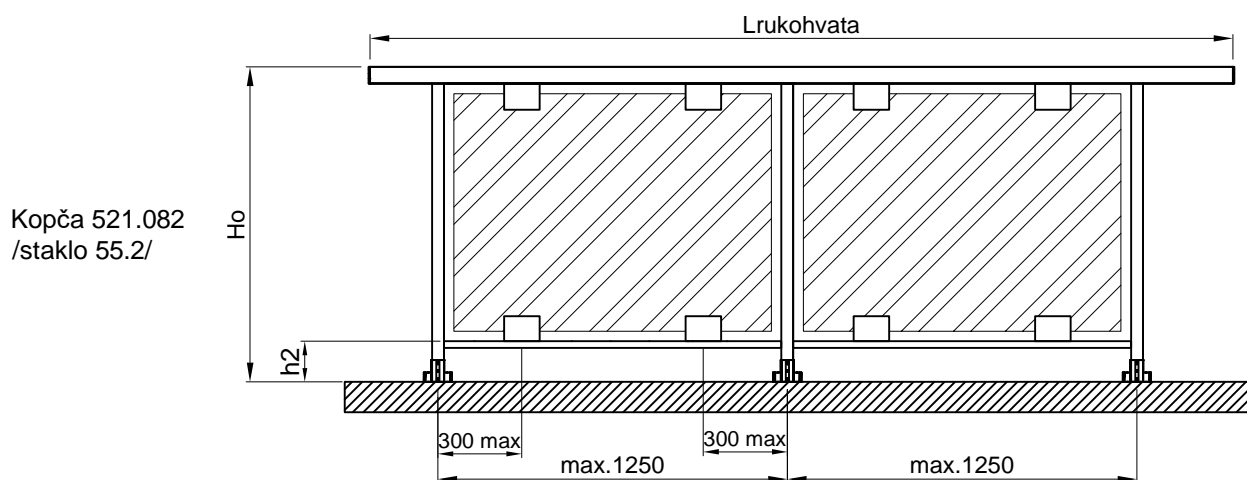

TIP C2

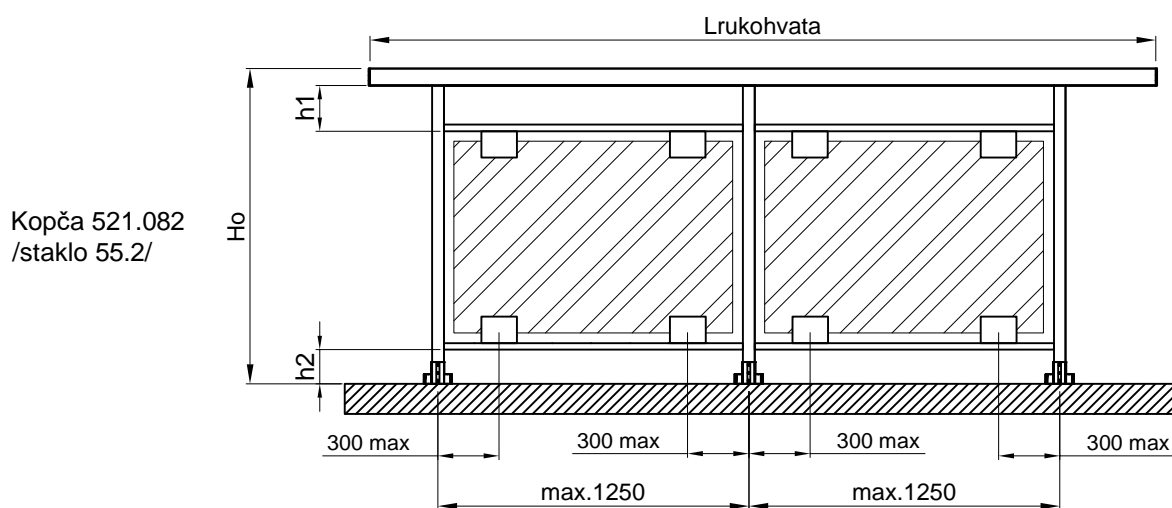

TIP C3

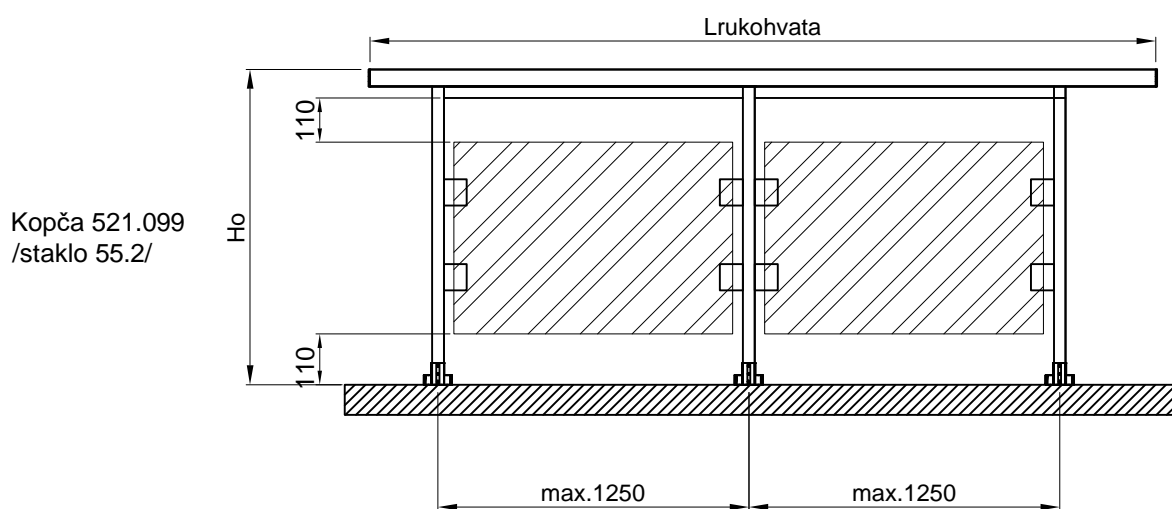

Držač stakla 521.082 /za staklo 55.2

TIP C4

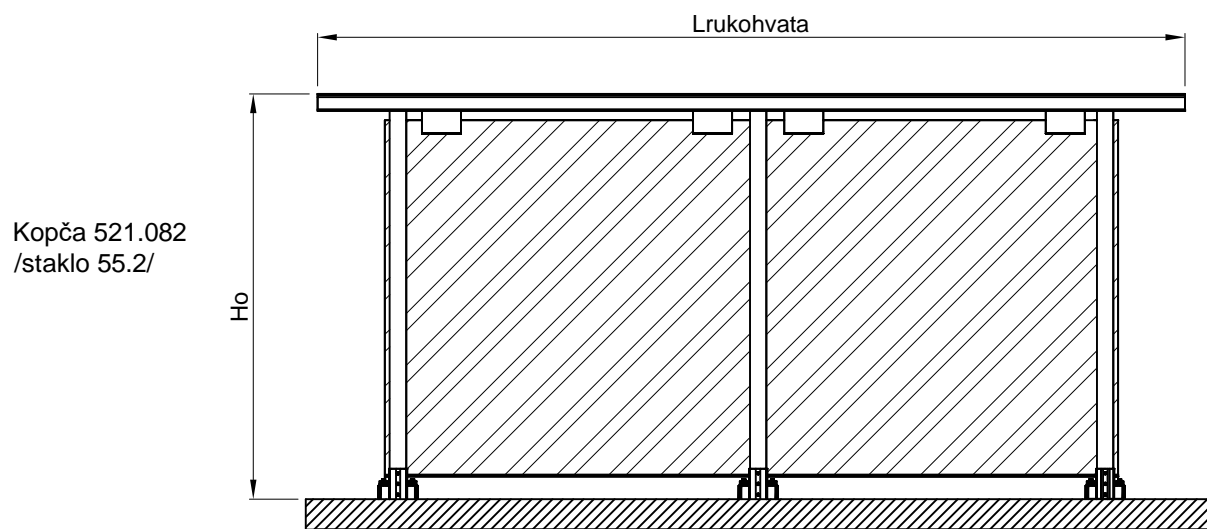

Staklena ograda sa kontinuiranom vodilicom (staklo 55.2)

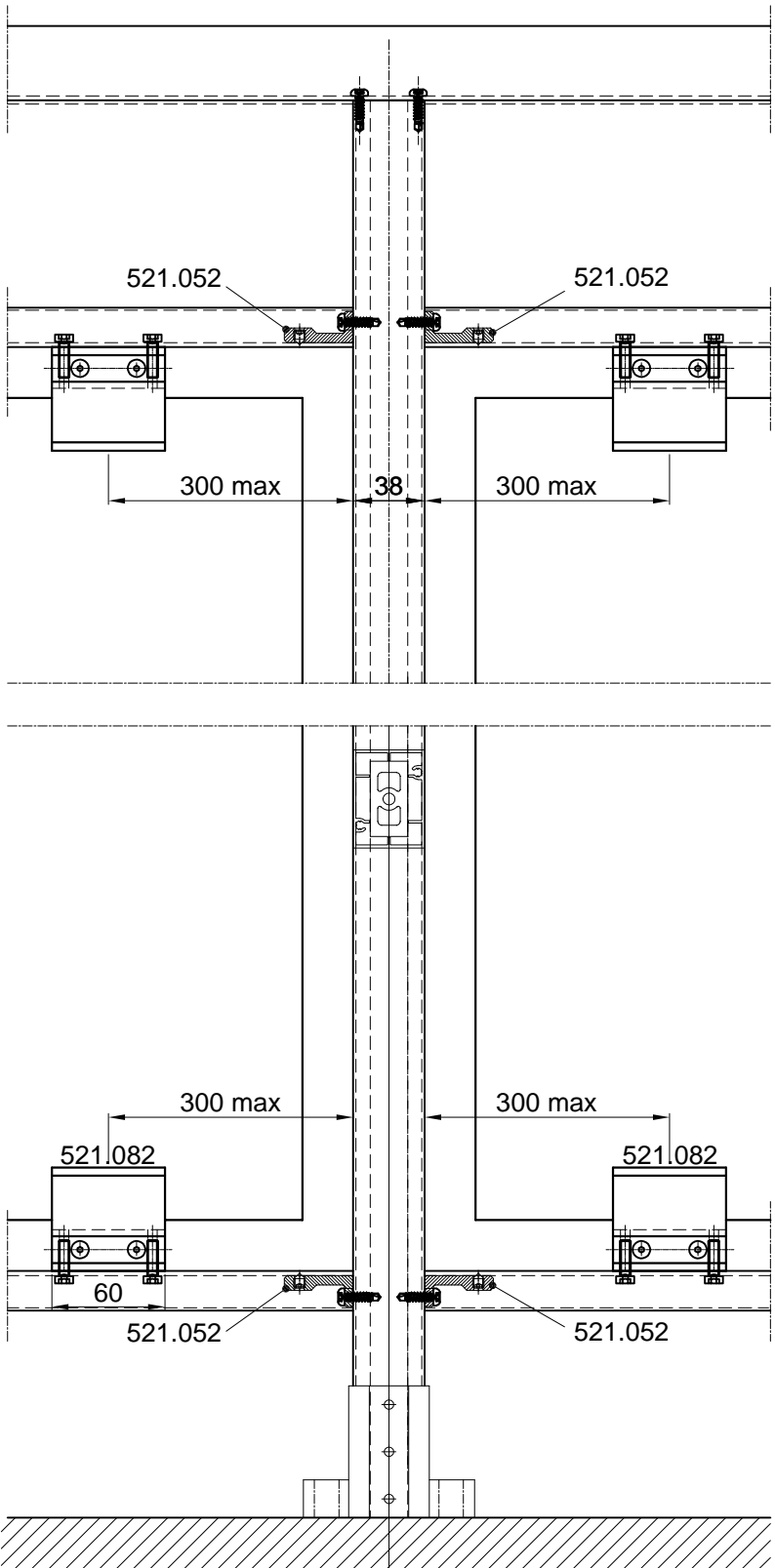
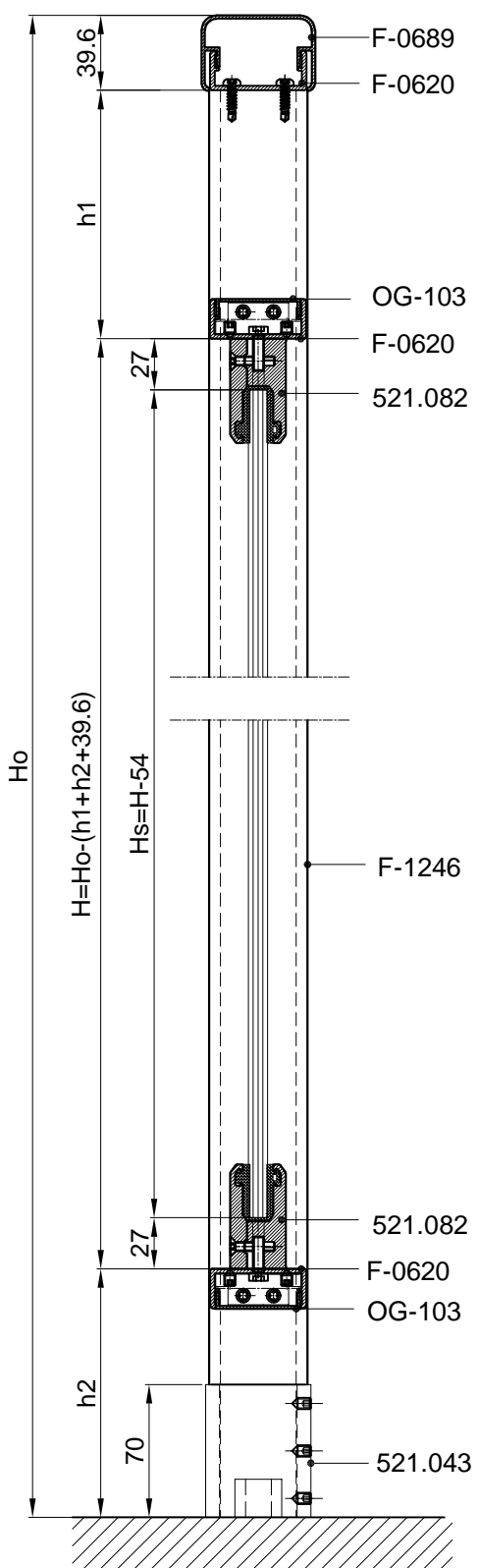
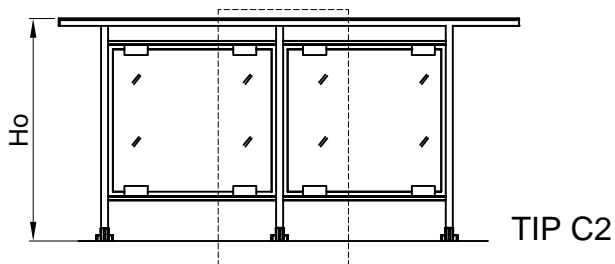

M 1:4

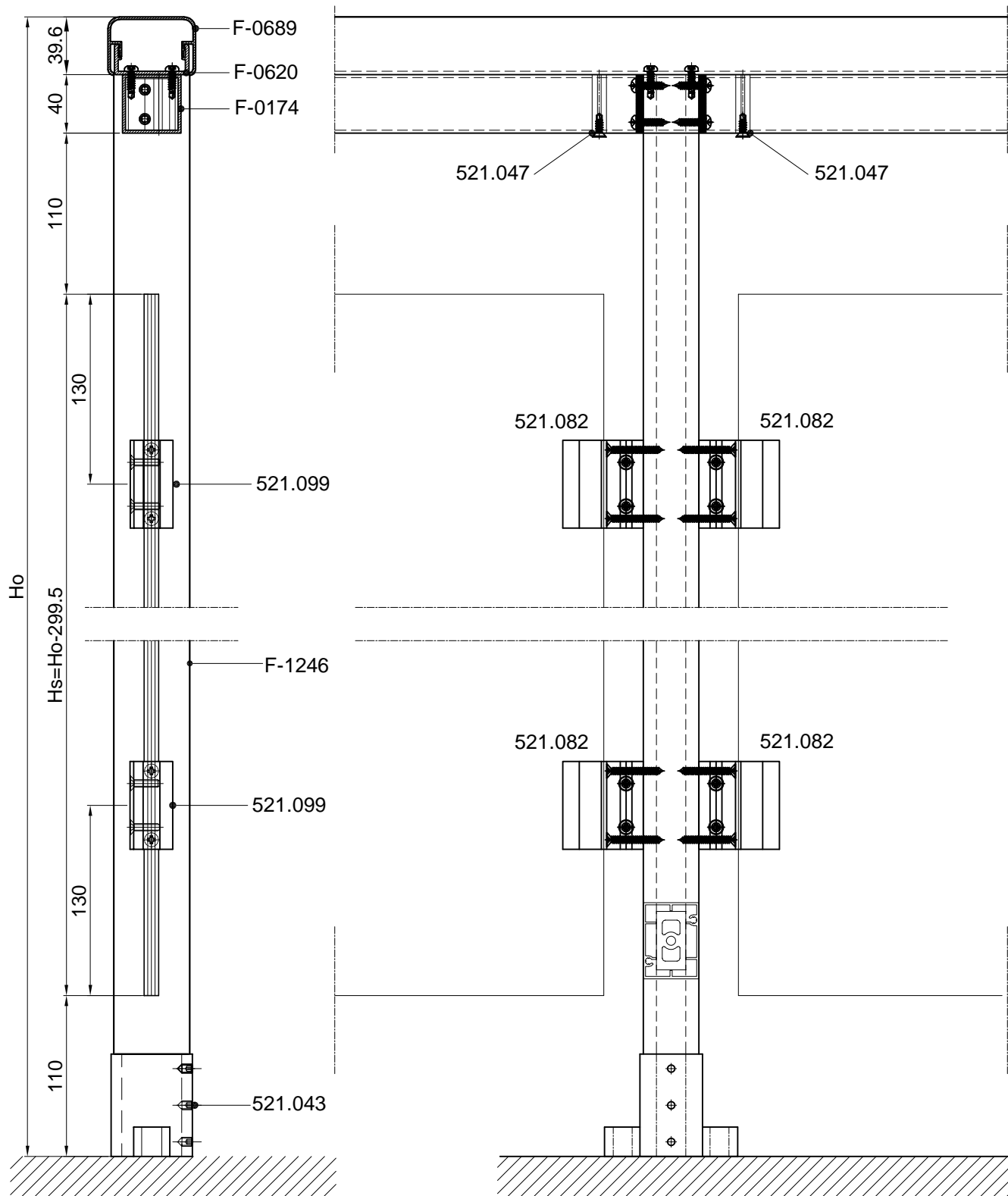
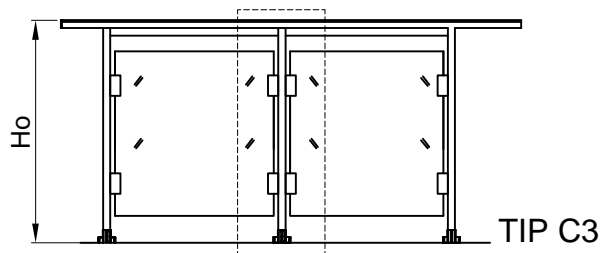

M 1:4

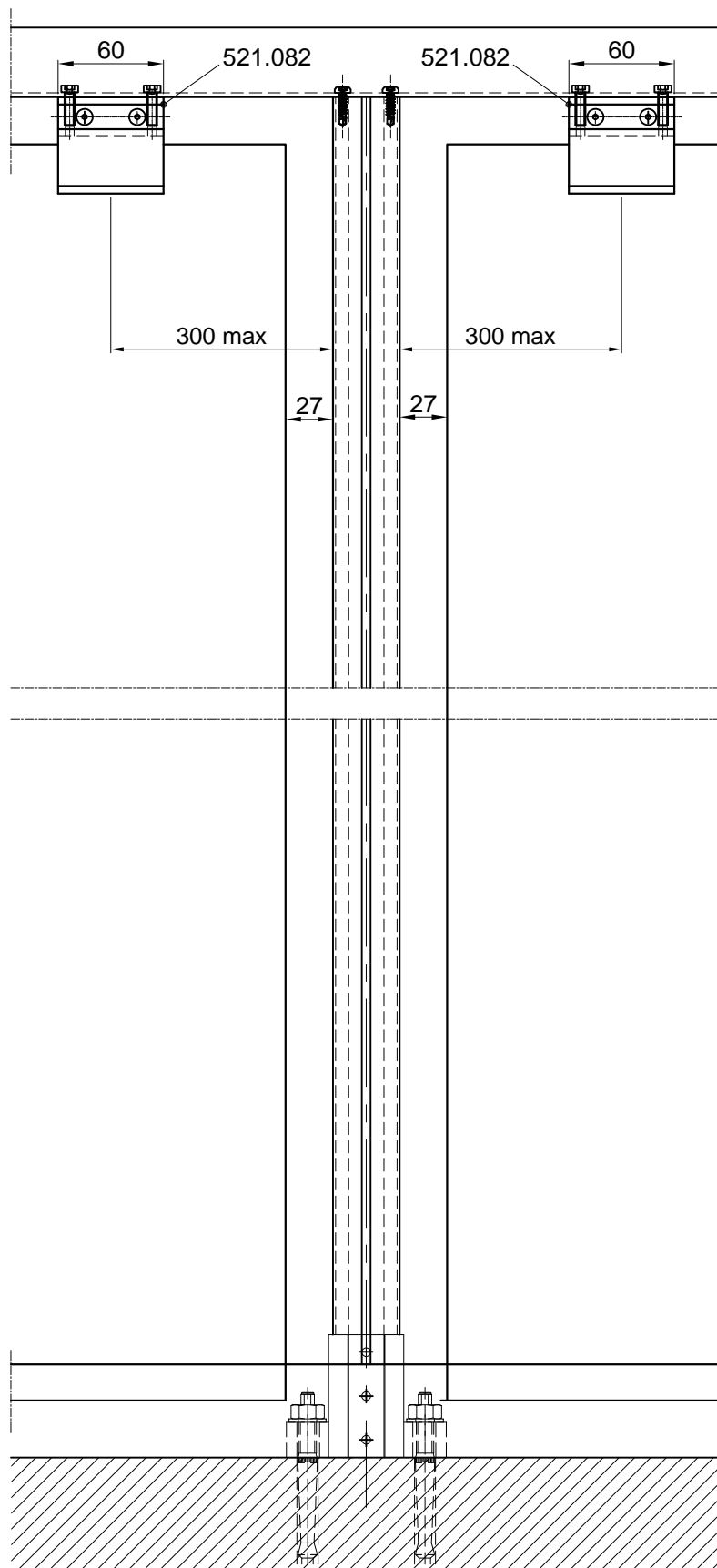
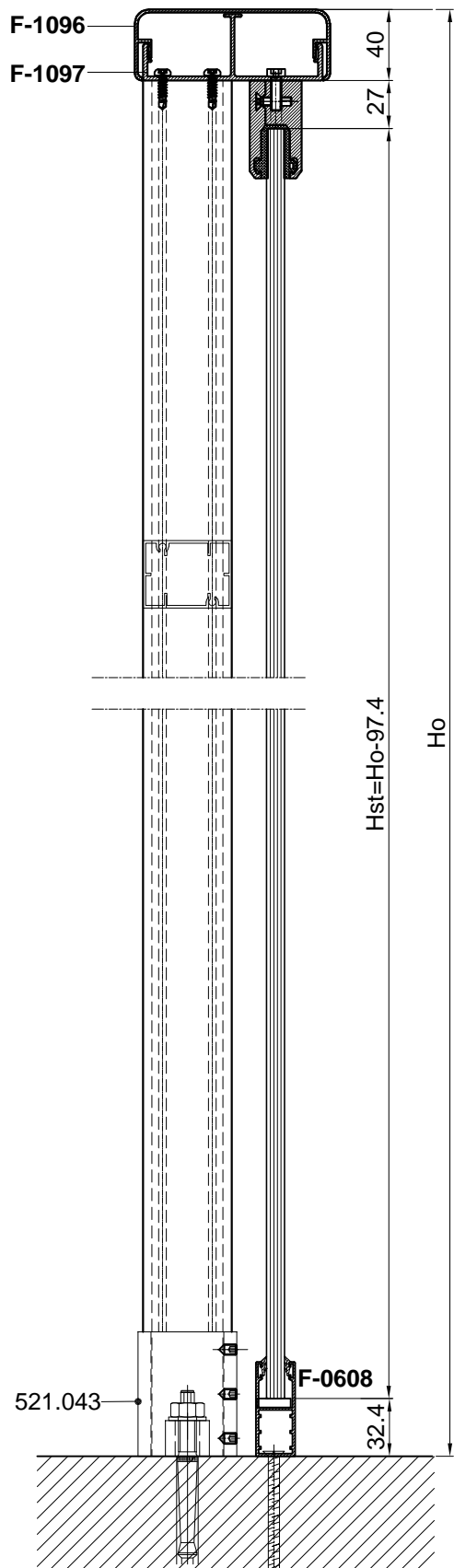
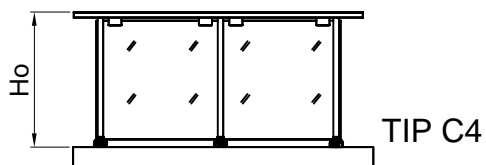

M 1:4

Držač stakla 521.045 /za staklo 44.2

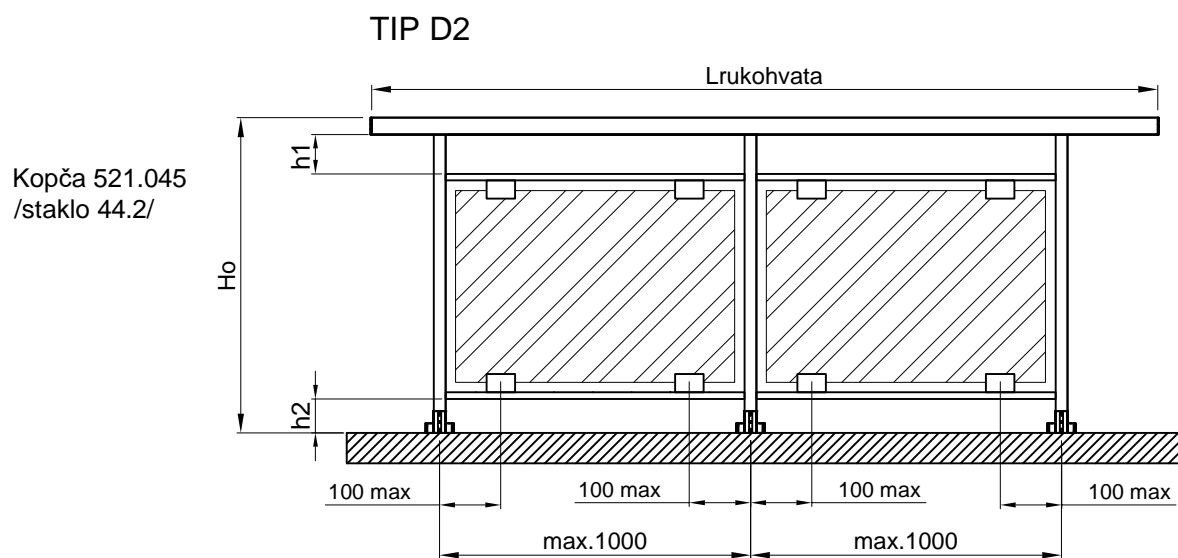
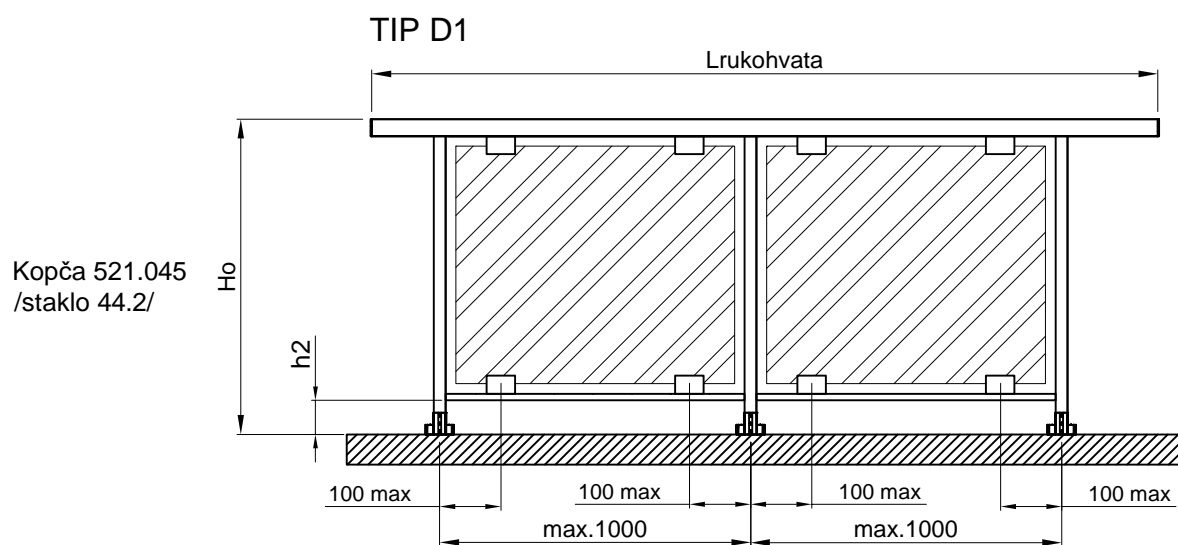

TIP B2

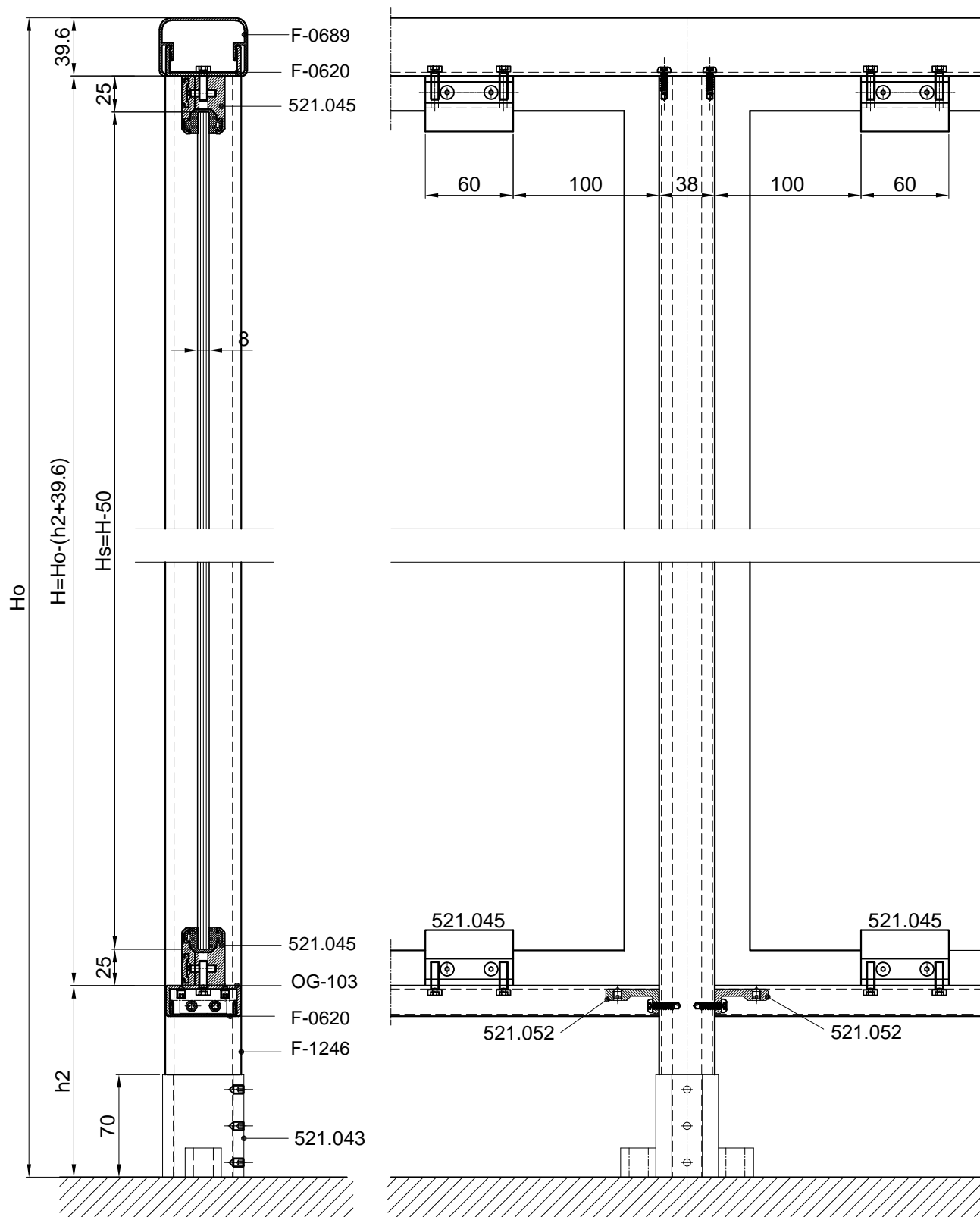
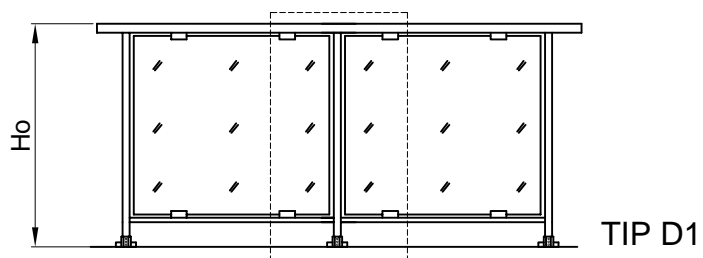

M 1:4

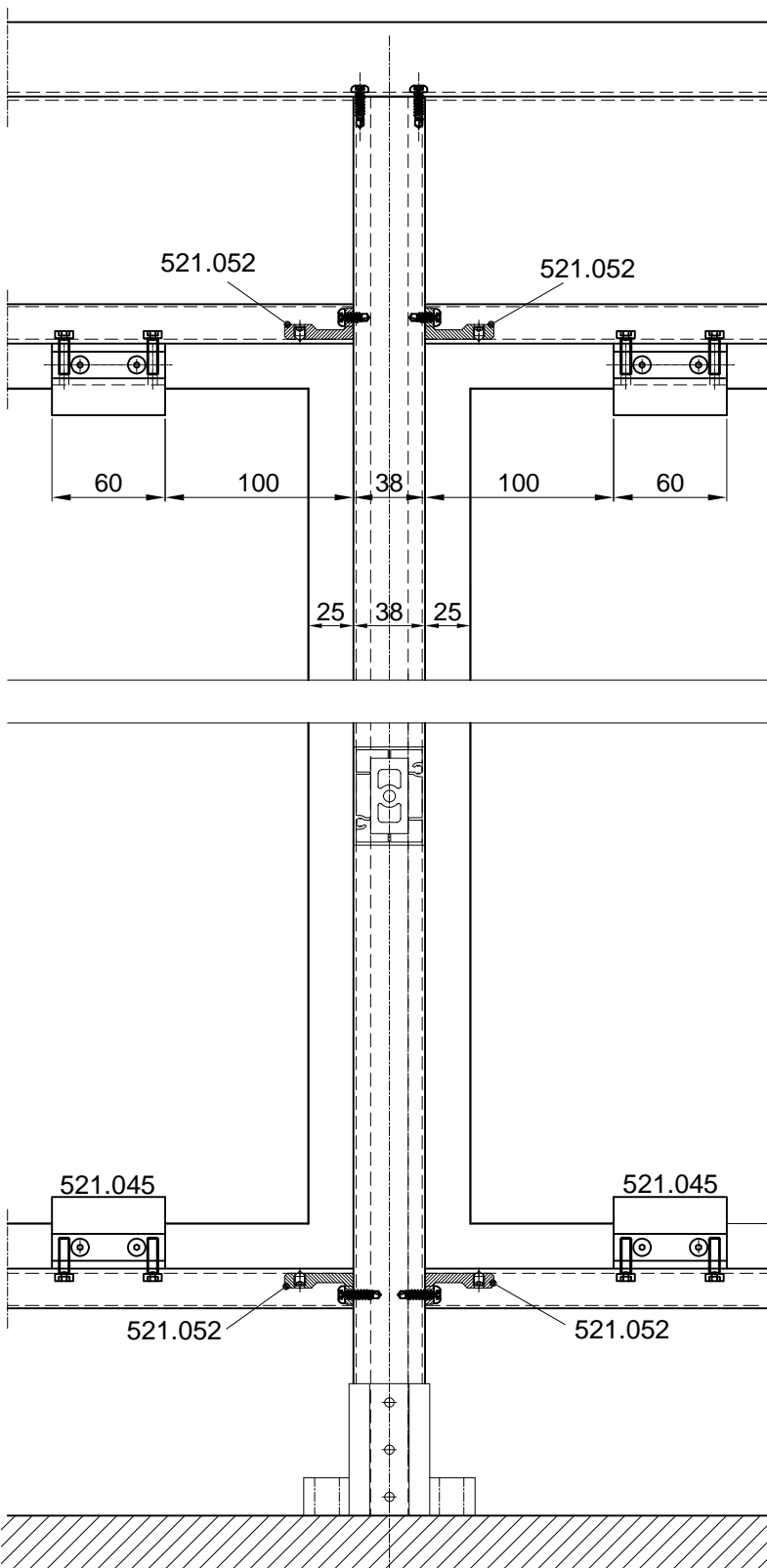
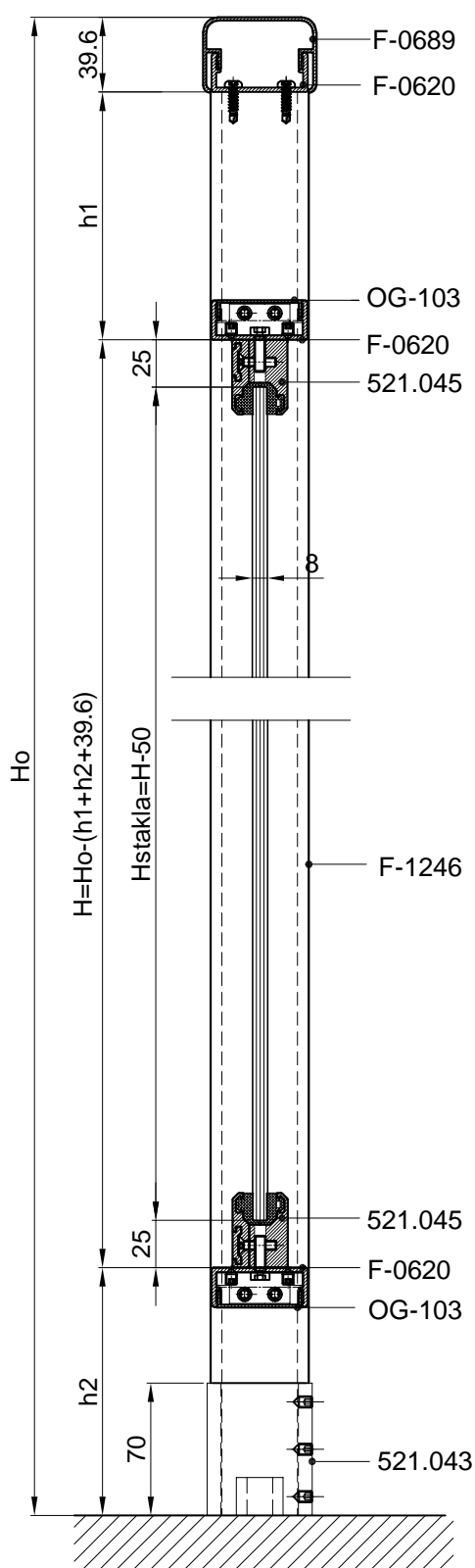
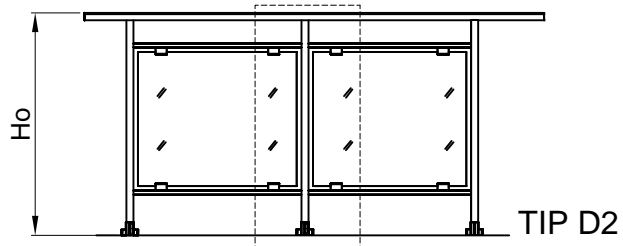

M 1:4

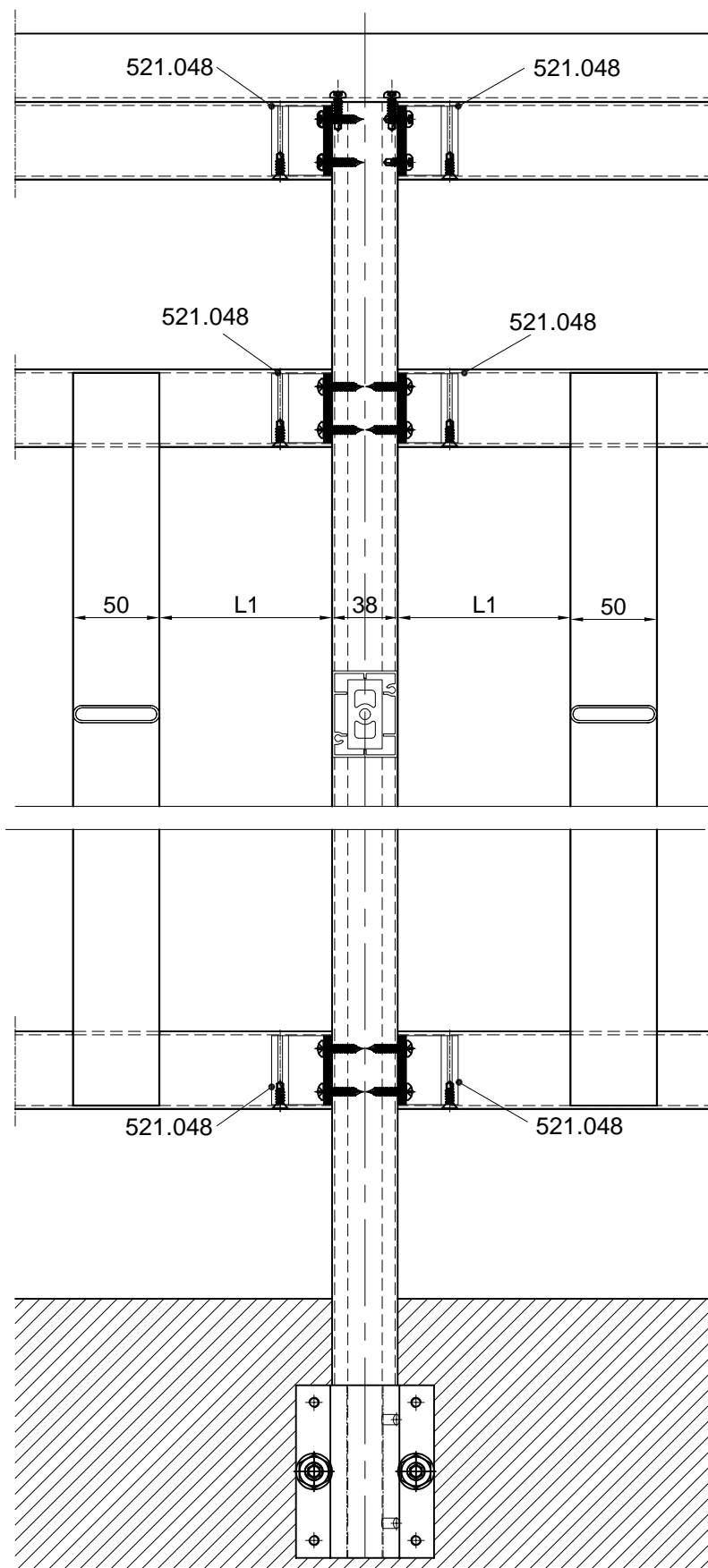
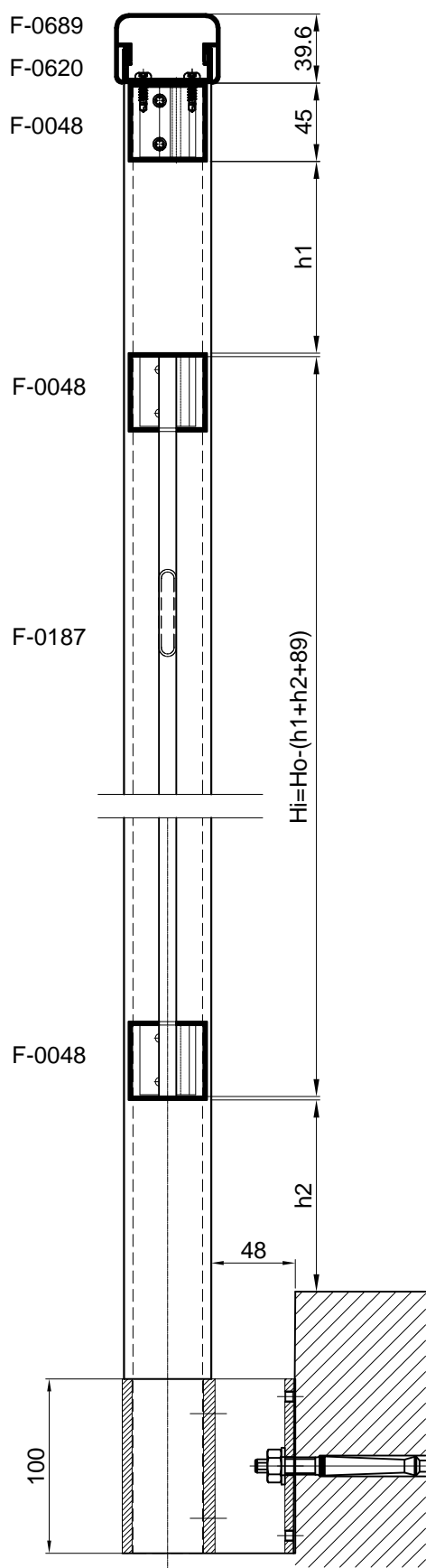

Obrada i montaža

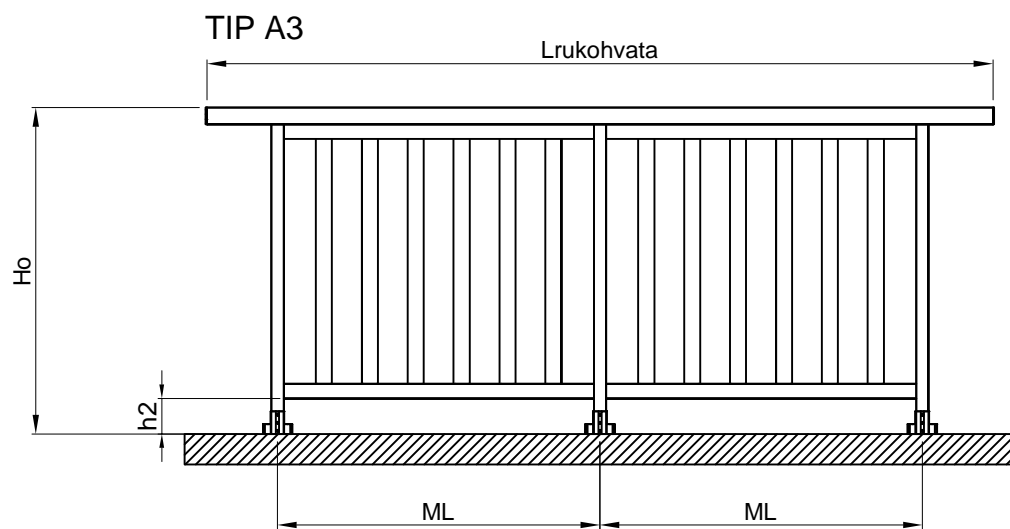
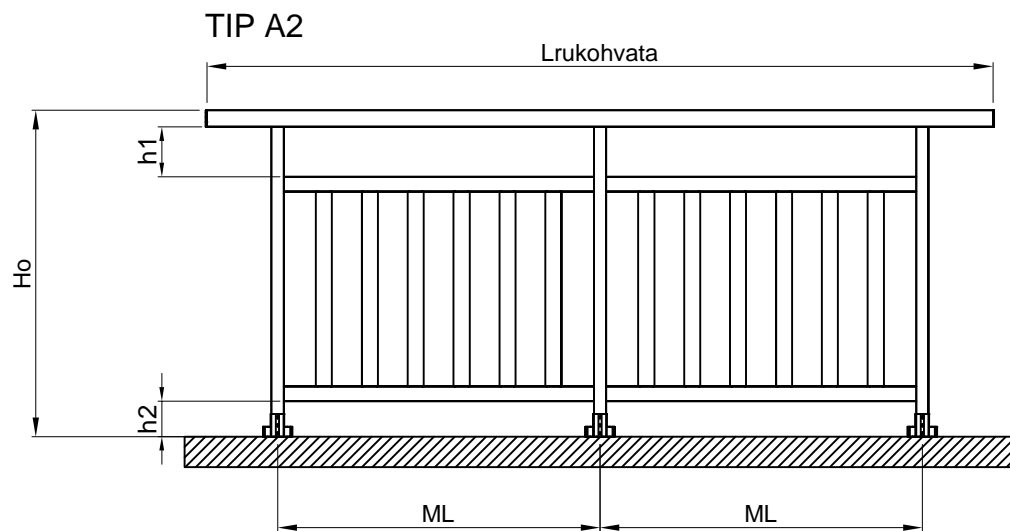
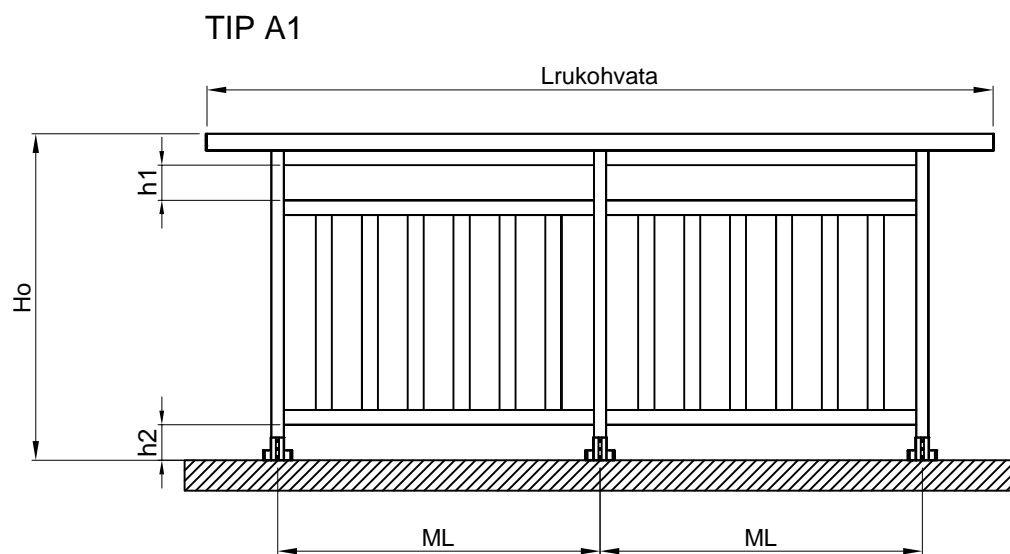

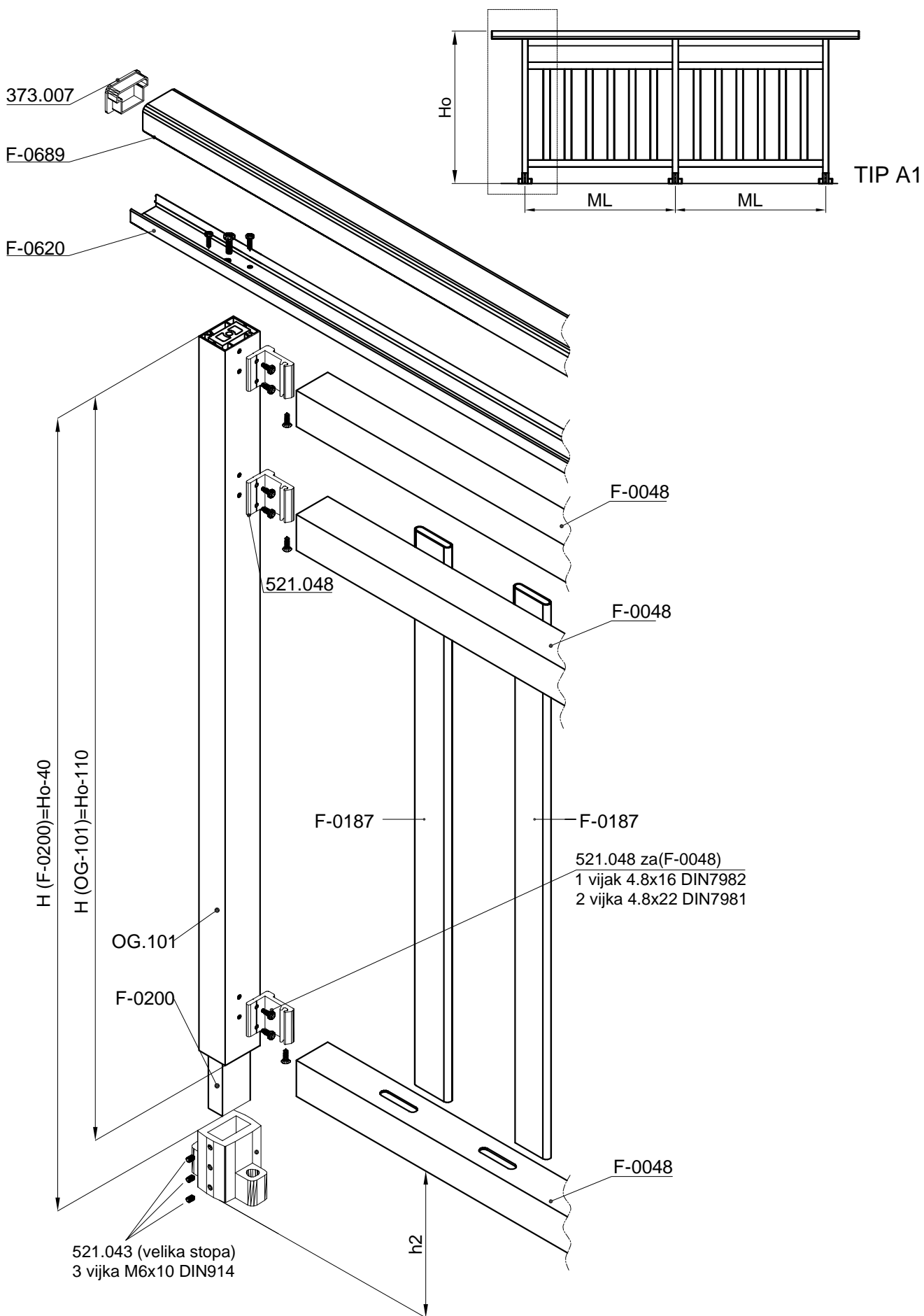

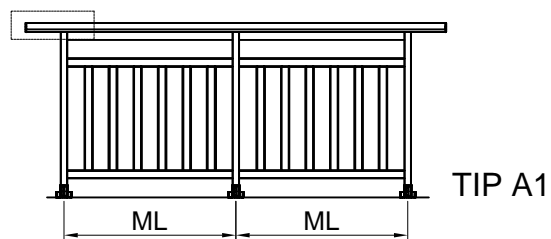

373.007 PVC
čep za rukohvat
F-0689

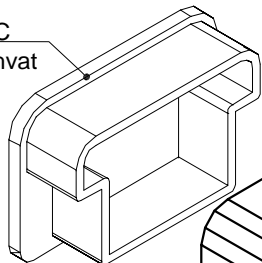

F-0689
rukohvat

2 vijka 4.8x19 DIN7981
1 Vijak M8x30 DIN 933
za spajanje (F-0620)
podrukohvata sa
al. stubom (OG-101)

F-620
podrukohvat

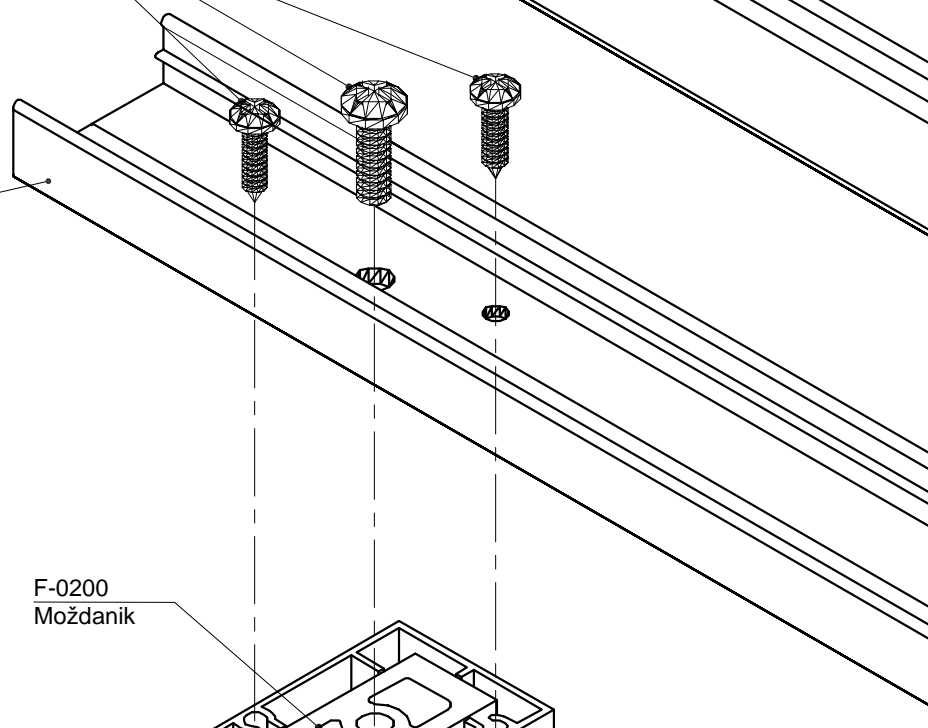

F-020
Moždanik

OG-101
Al stub

F-0200
Moždanik

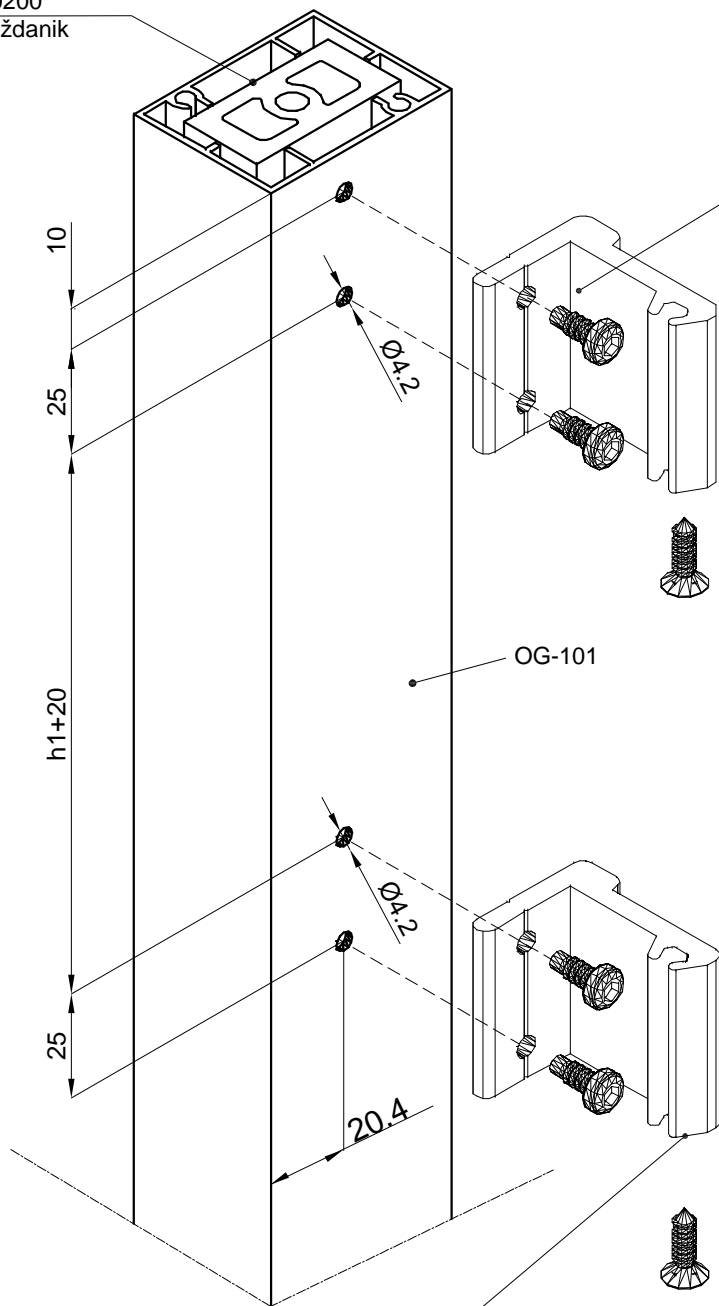

521.048 za(F-0048)
1 vijak 4.8x16 DIN7982
2 vijka 4.8x22 DIN7981

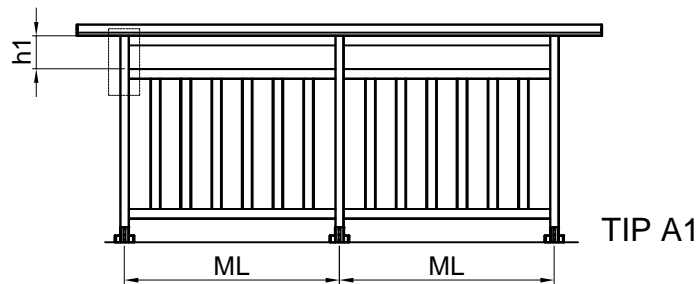

521.048 za(F-0048)
1 vijak 4.8x16 DIN7982
2 vijka 4.8x22 DIN7981

(F-0048-prečka pod rukohvatom),
spaja se preko veznika (521.048)
za al stub (OG101)

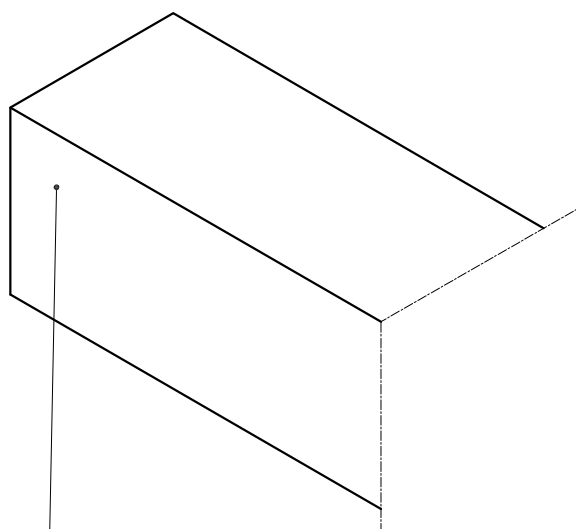
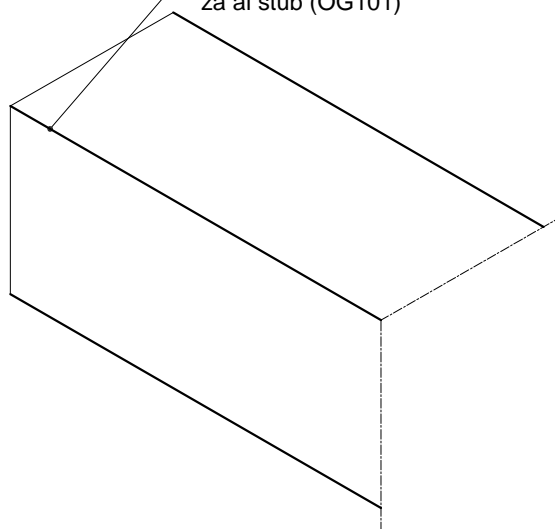

(F-0048-sr. horizont. prečka),
spaja se preko veznika (521.048)
za al stub (OG101)

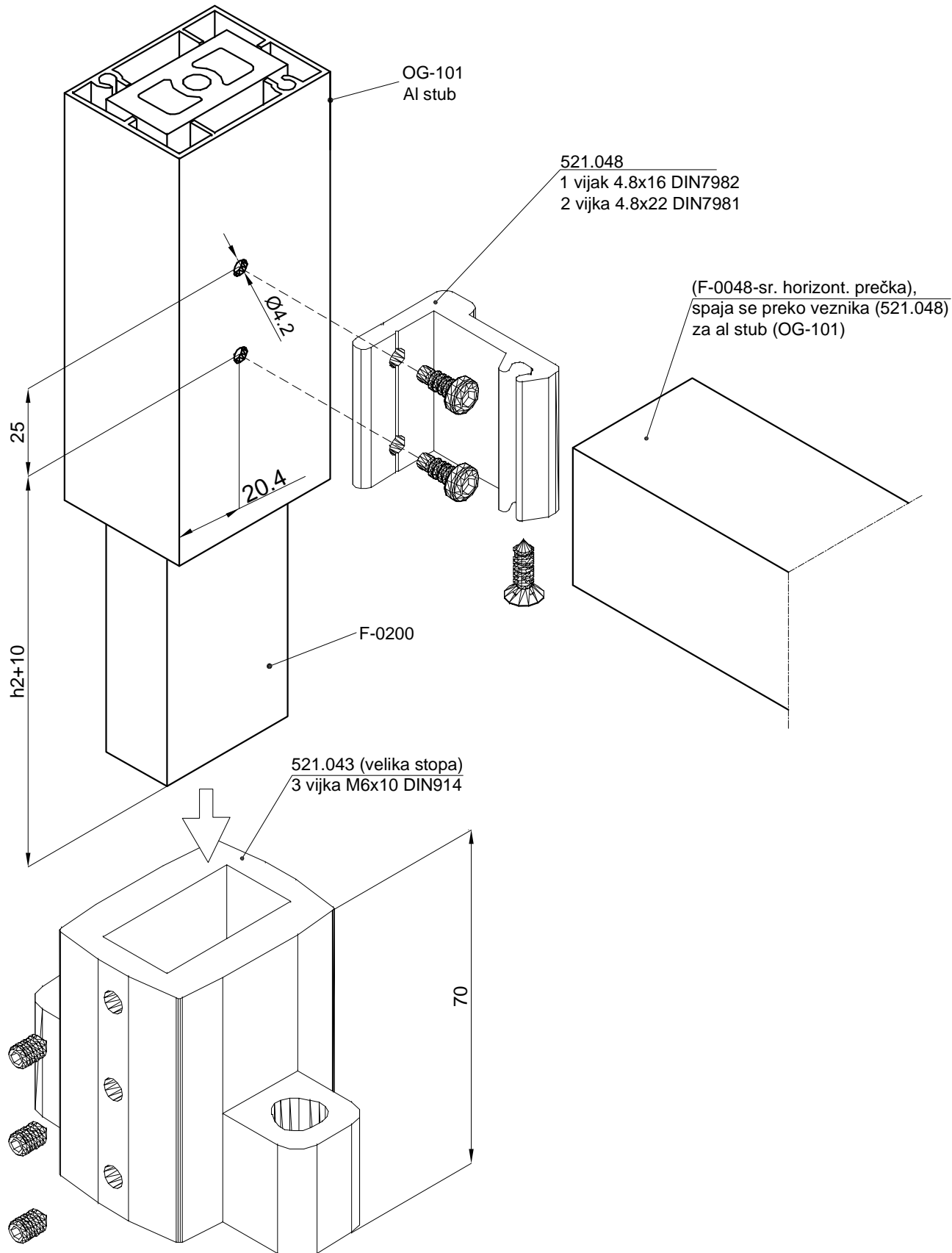
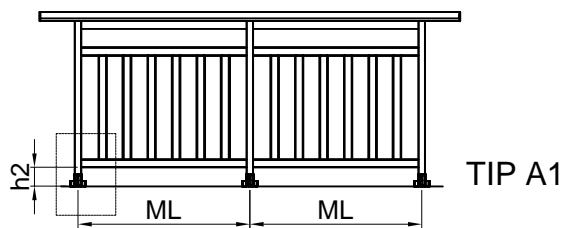

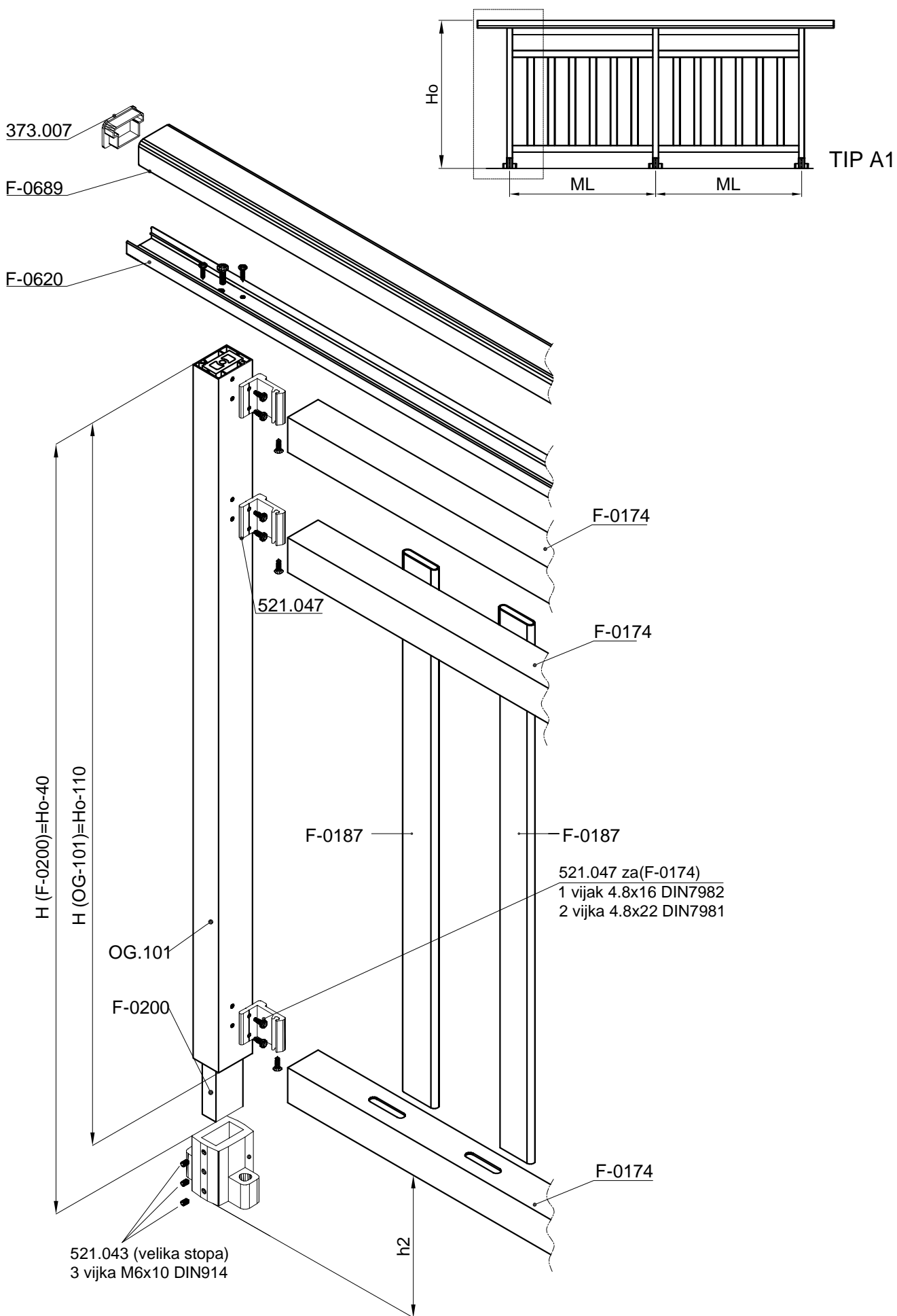

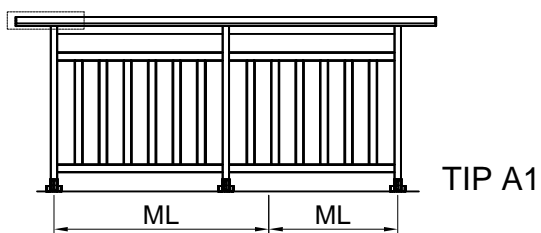

373.007 PVC
čep za rukohvat
F-0689

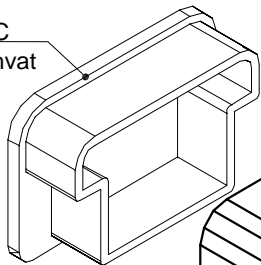

F-0689
rukohvat

2 vijka 4.8x19 DIN7981
1 Vijak M8x30 DIN 933
za spajanje (F-0620)
podrukohvata sa
al. stubom (OG-101)

F-620
podrukohvat

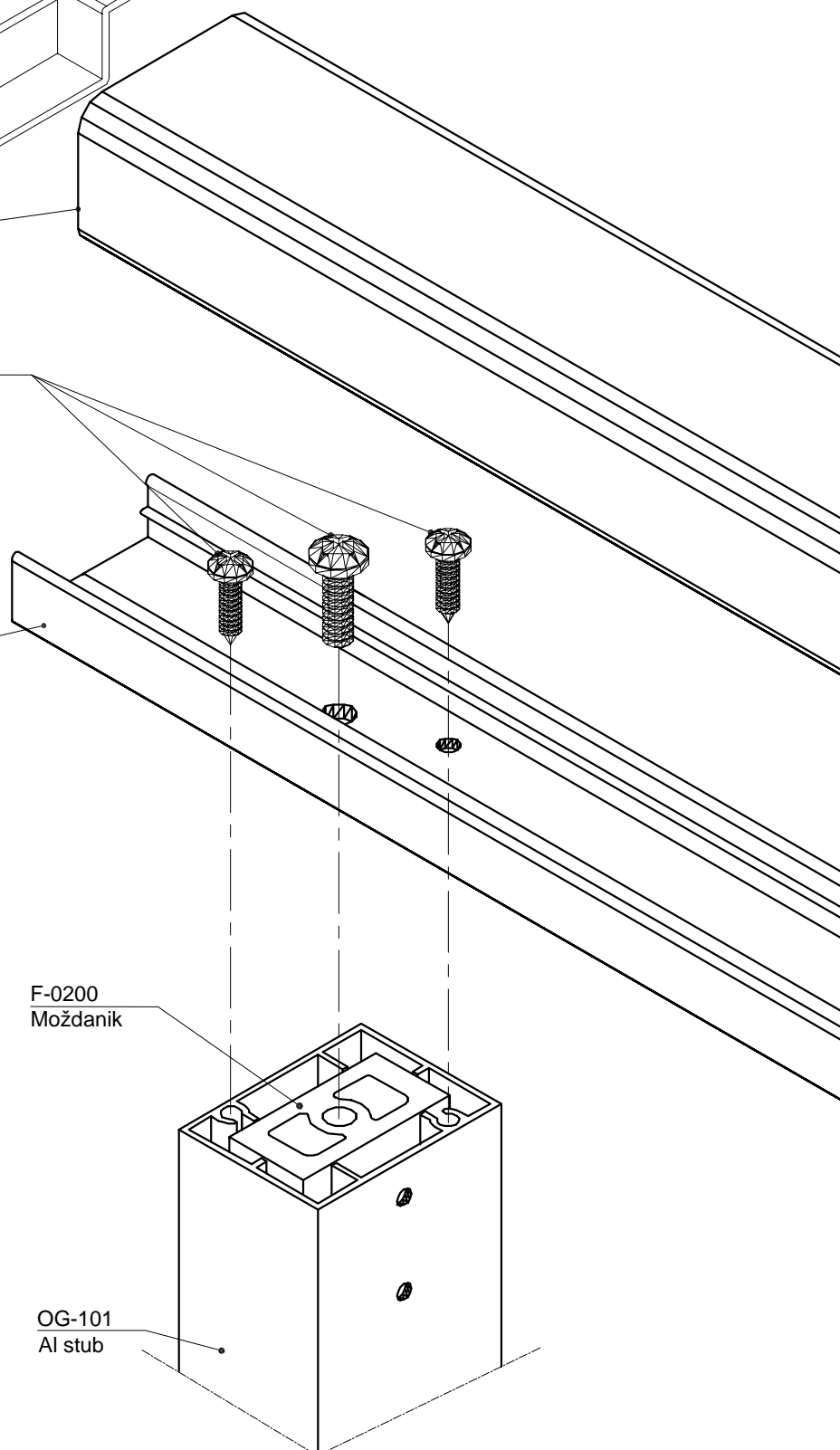

F-020
Moždanik

OG-101
Al stub

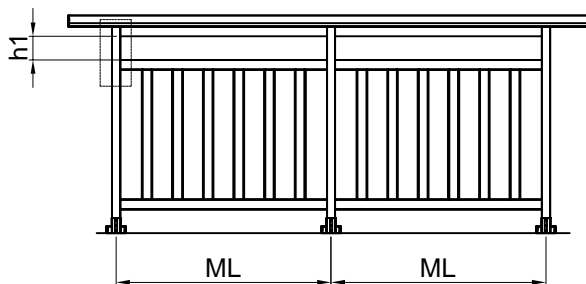

TIP A1

F-0200
Moždanik

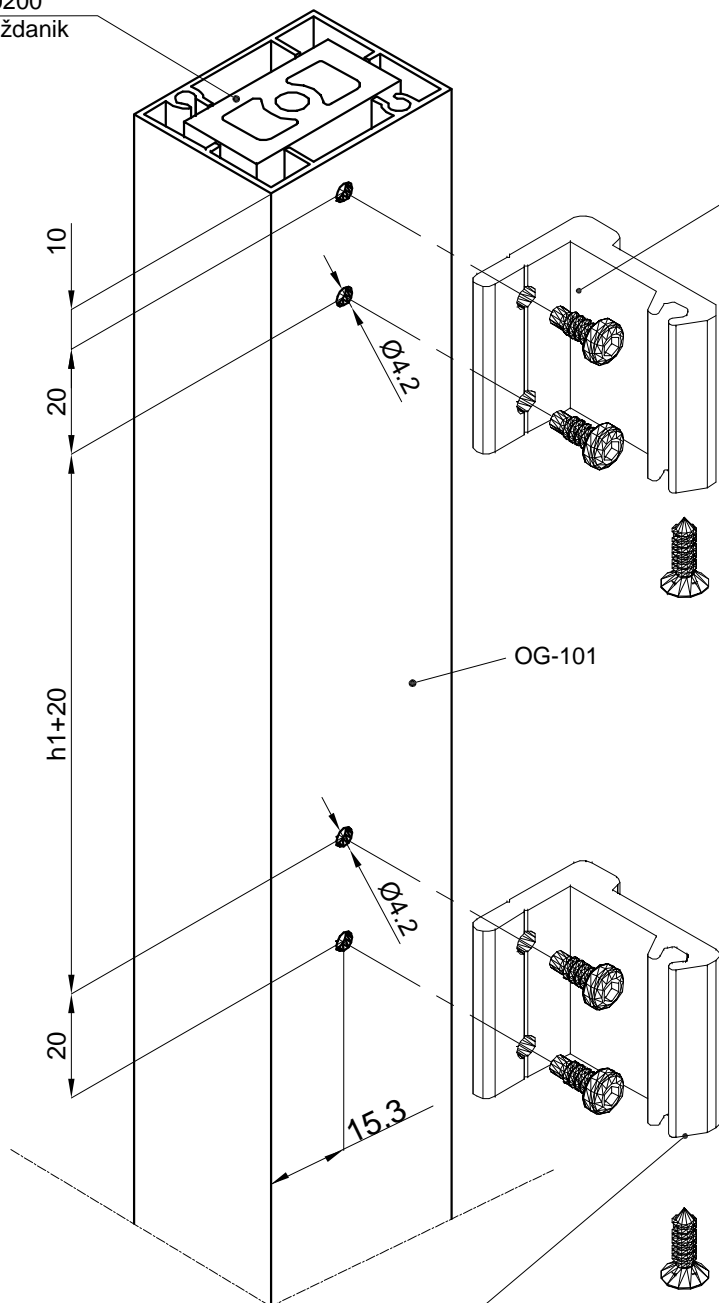

521.047 za(F-0174)
1 vijak 4.8x16 DIN7982
2 vijka 4.8x22 DIN7981

(F-0174-prečka pod rukohvatom),
spaja se preko veznika (521.047)
za al stub (OG101)

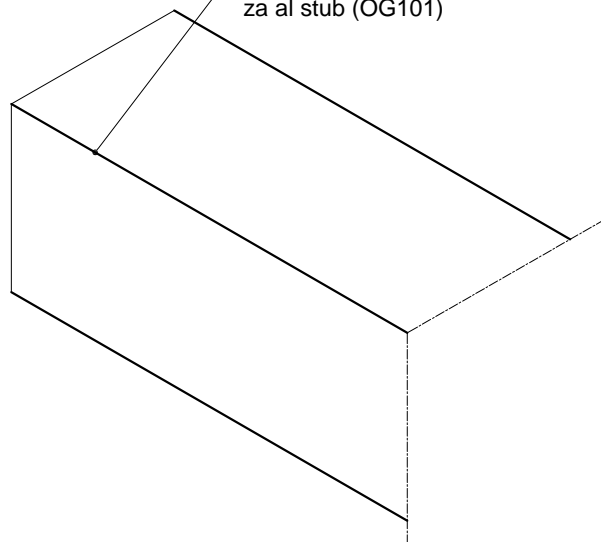

521.047 za(F-0174)
1 vijak 4.8x16 DIN7982
2 vijka 4.8x22 DIN7981

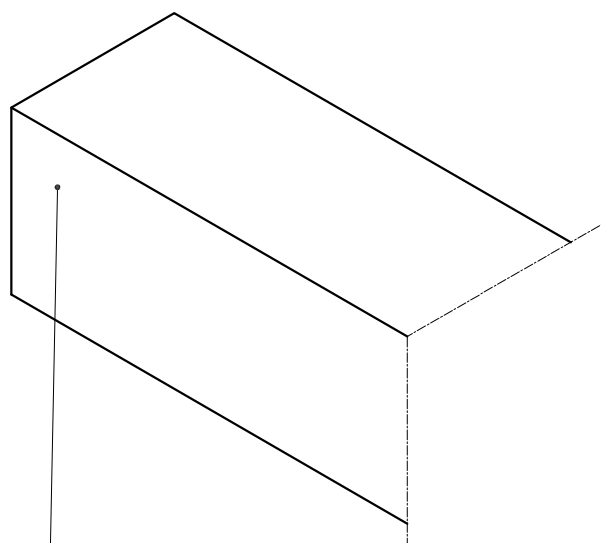

(F-0174-sr. horizont. prečka),
spaja se preko veznika (521.047)
za al stub (OG101)

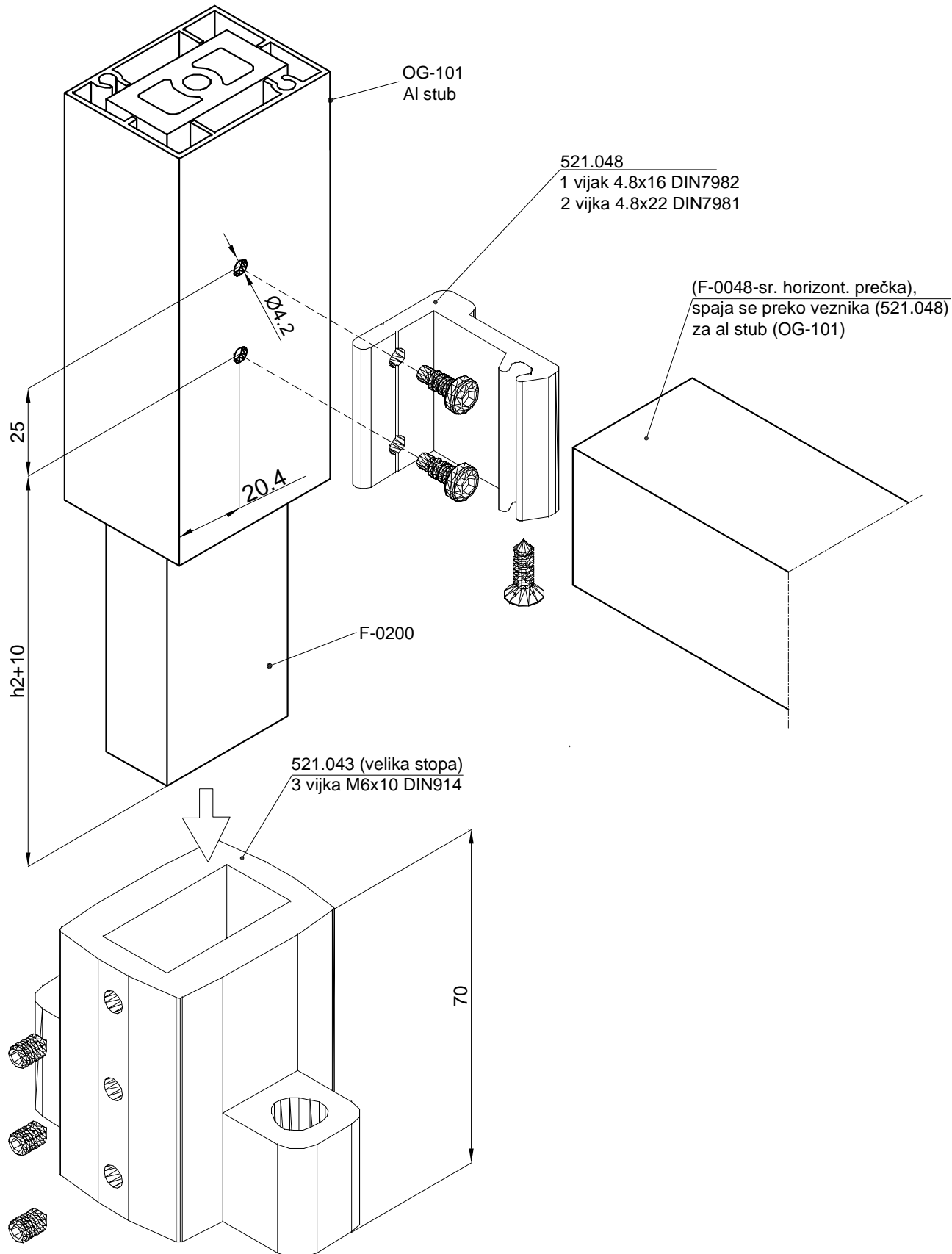
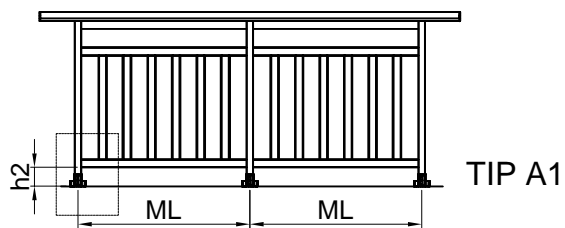

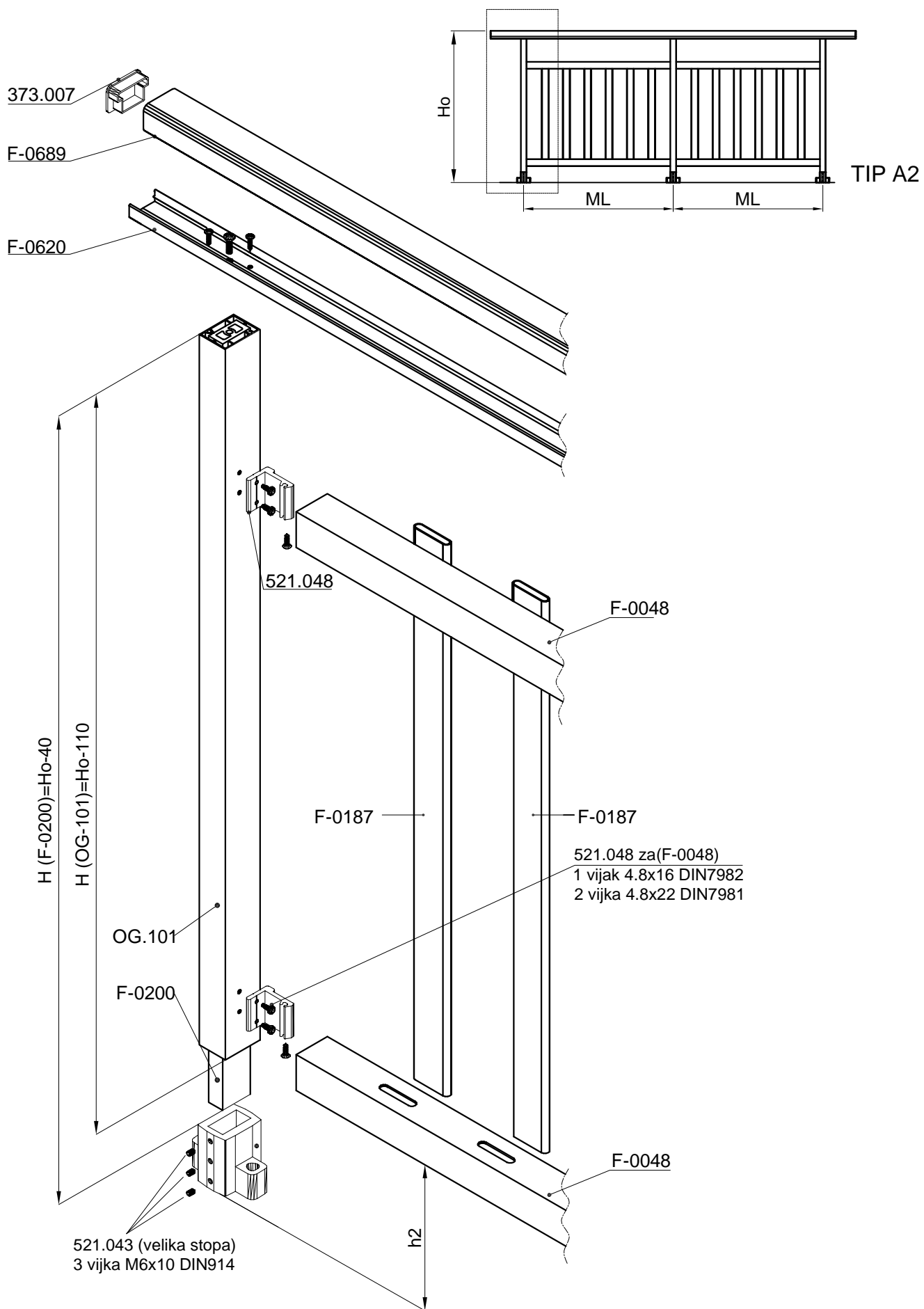

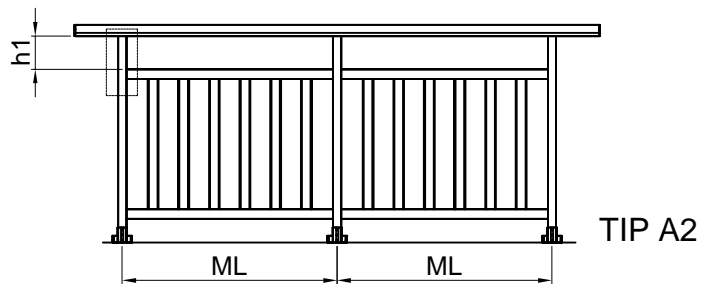

F-0200
Moždanik

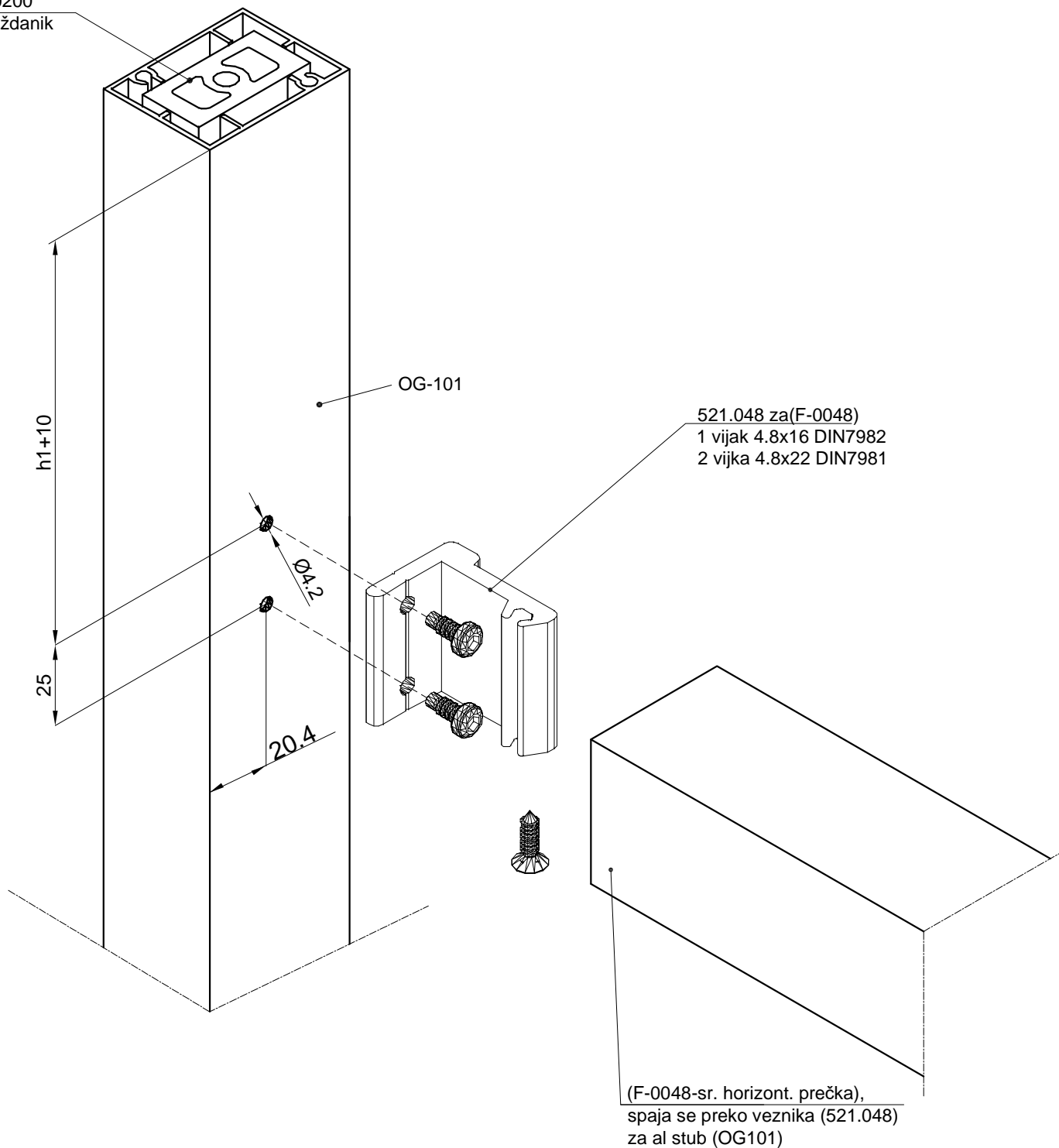

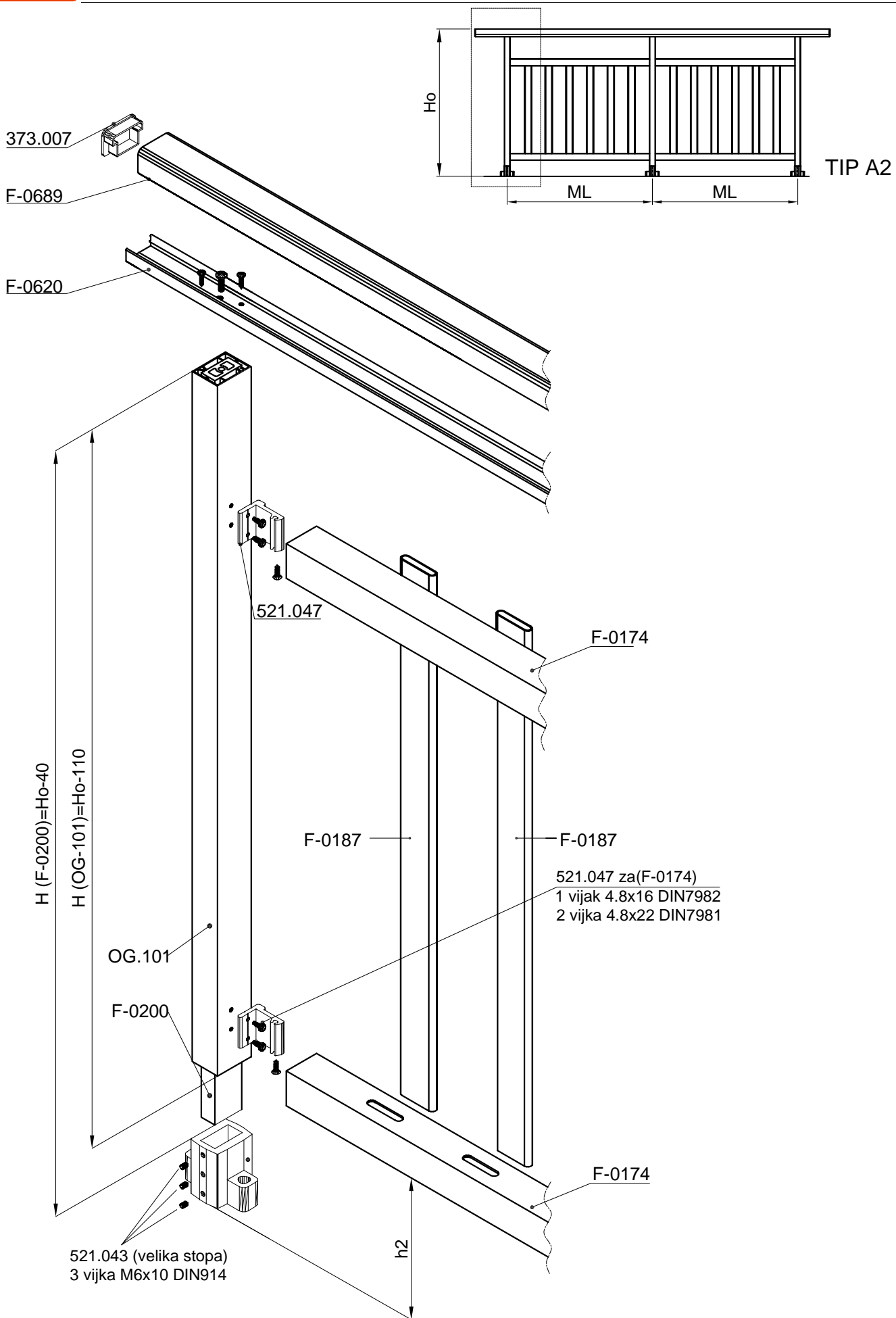

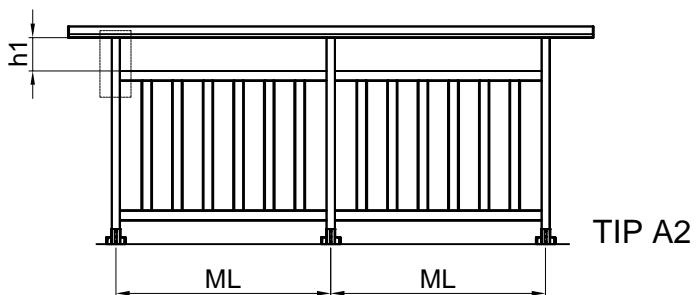

F-0200
Moždanik

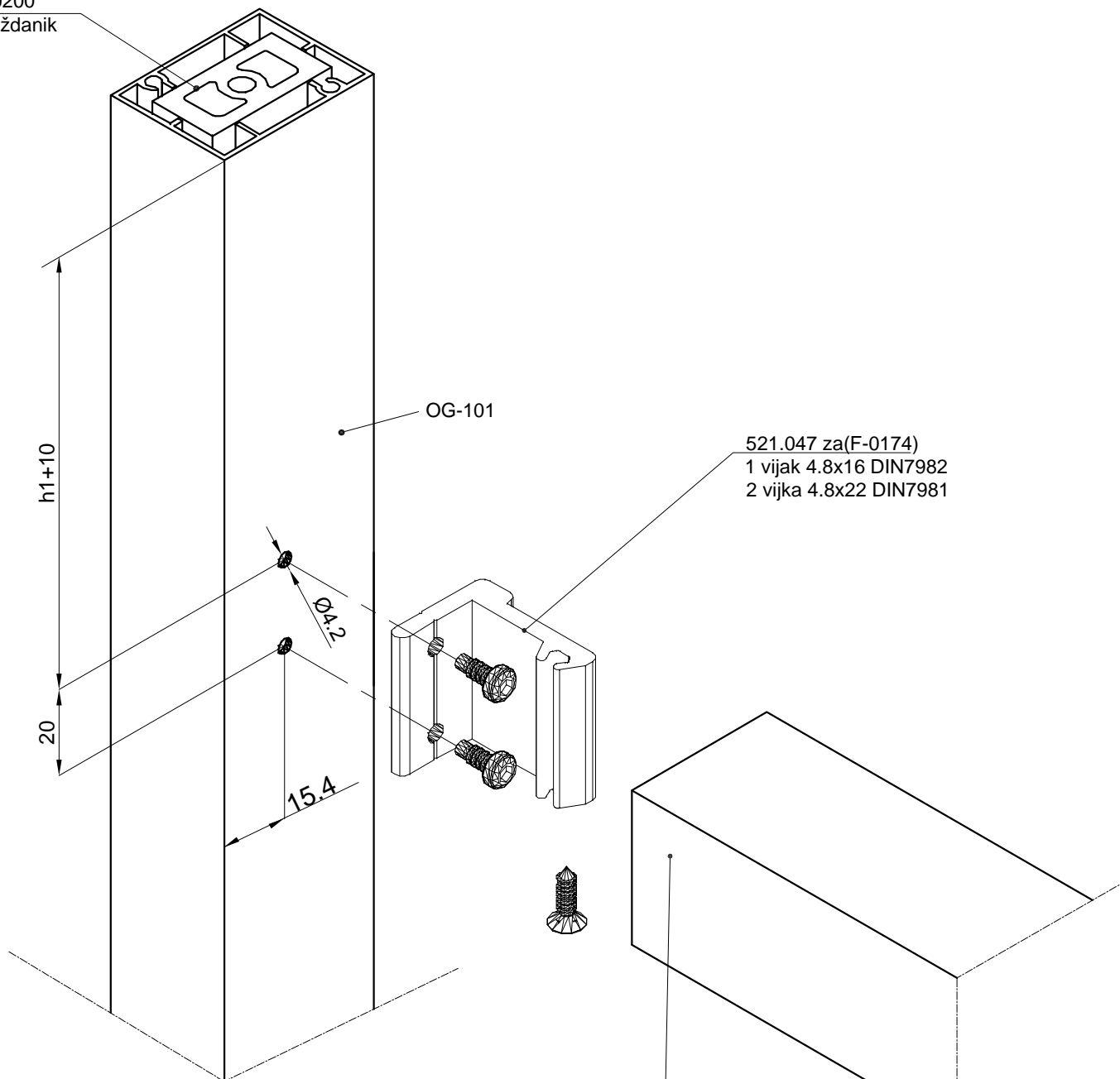

(F-0174-sr. horizont. prečka),
spaja se preko veznika (521.047)
za al stub (OG101)

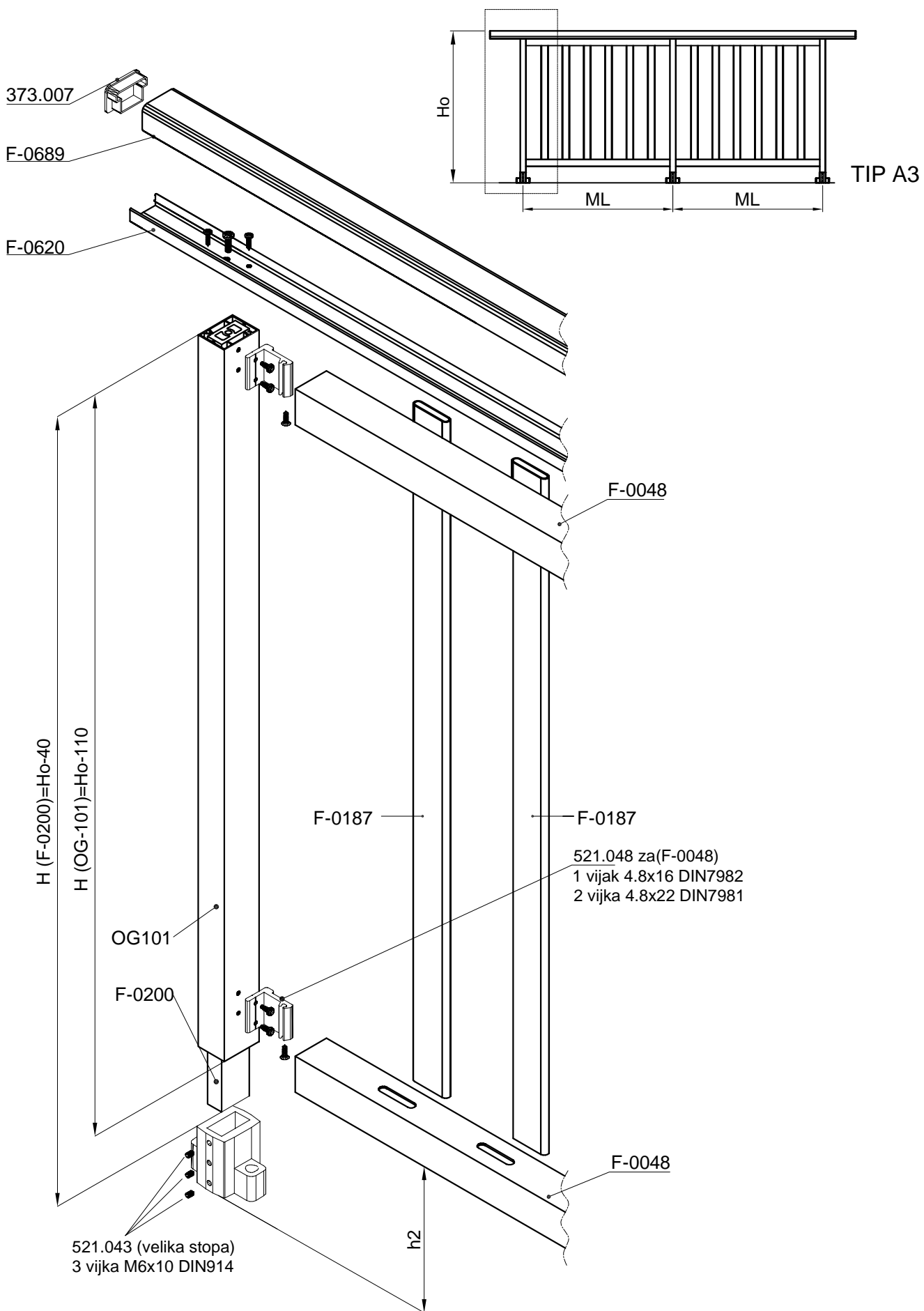

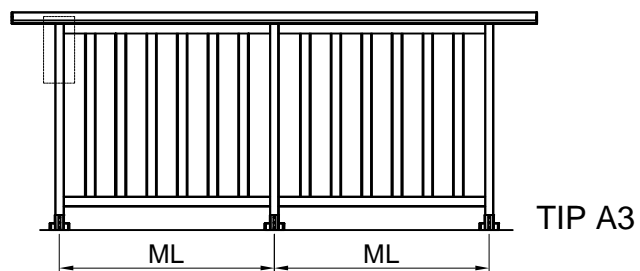

F-0200
Moždanik

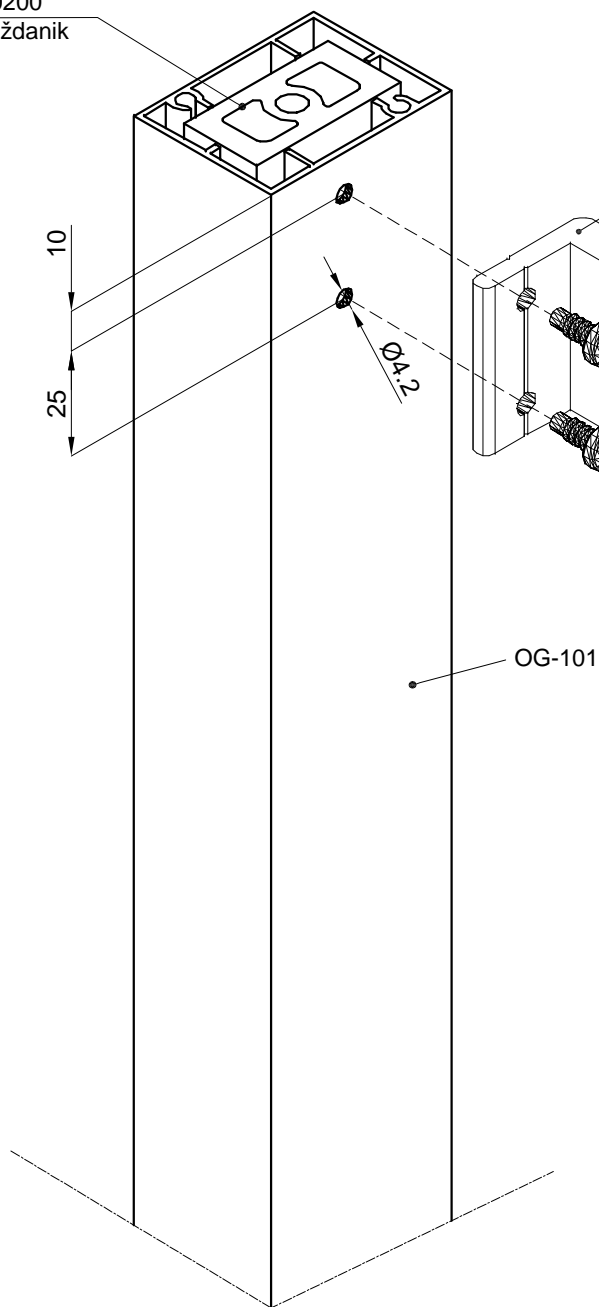

521.048 za(F-0048)
1 vijak 4.8x16 DIN7982
2 vijka 4.8x22 DIN7981

(F-0048-prečka pod rukohvatom),
spaja se preko veznika (521.048)
za al stub (OG101)

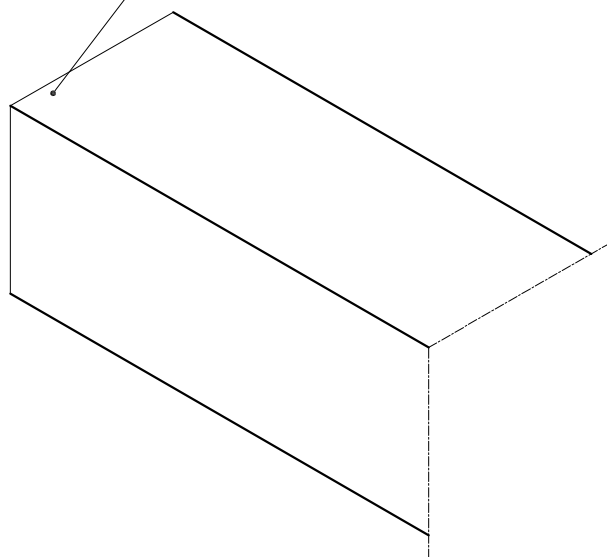

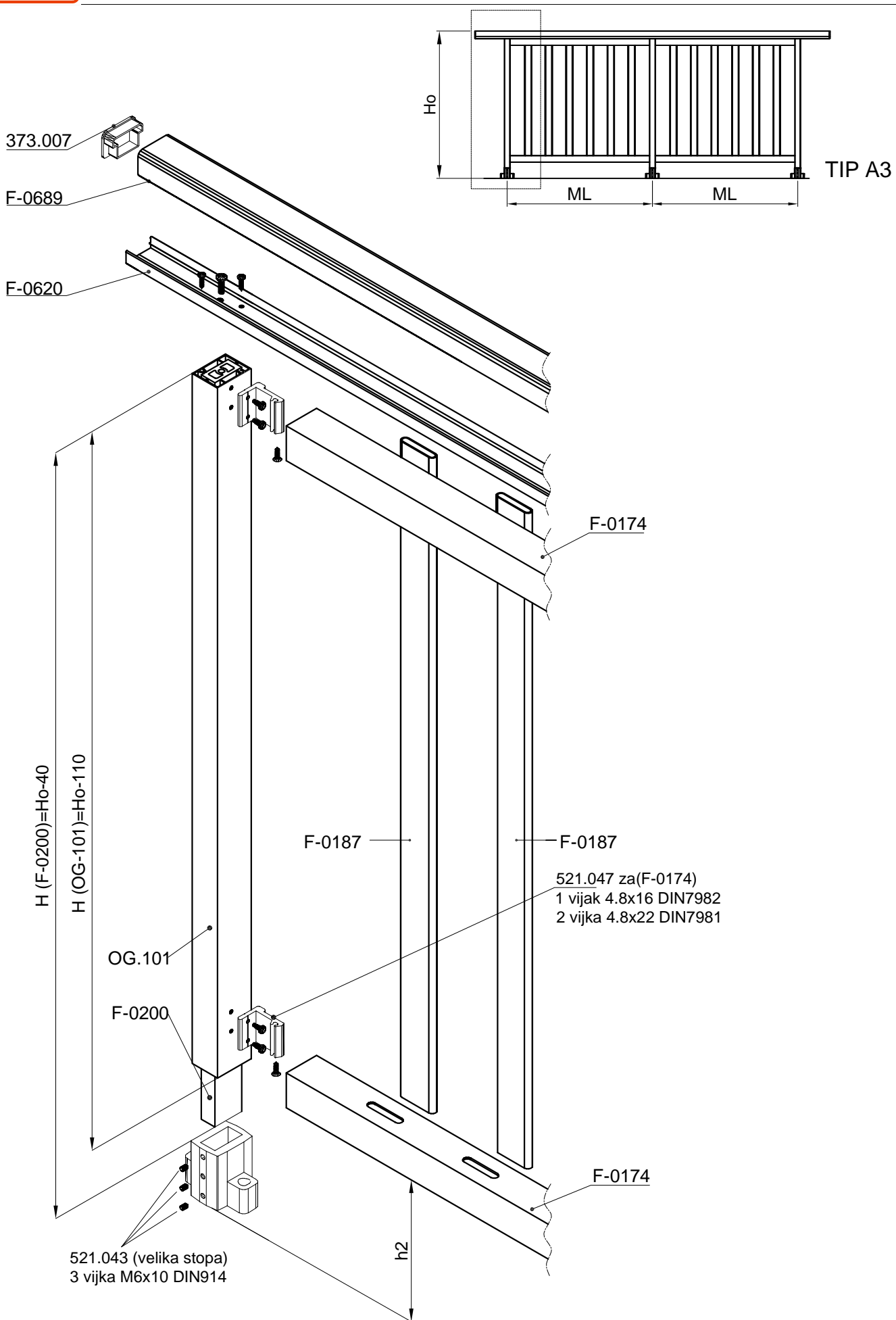

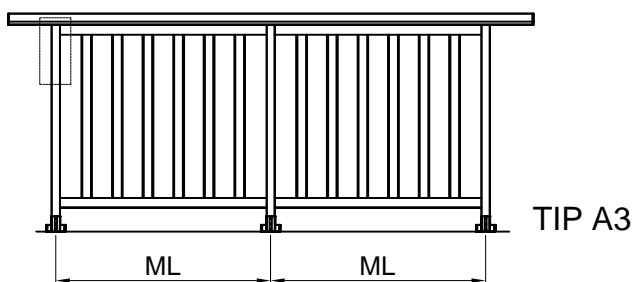

F-0200
Moždanik

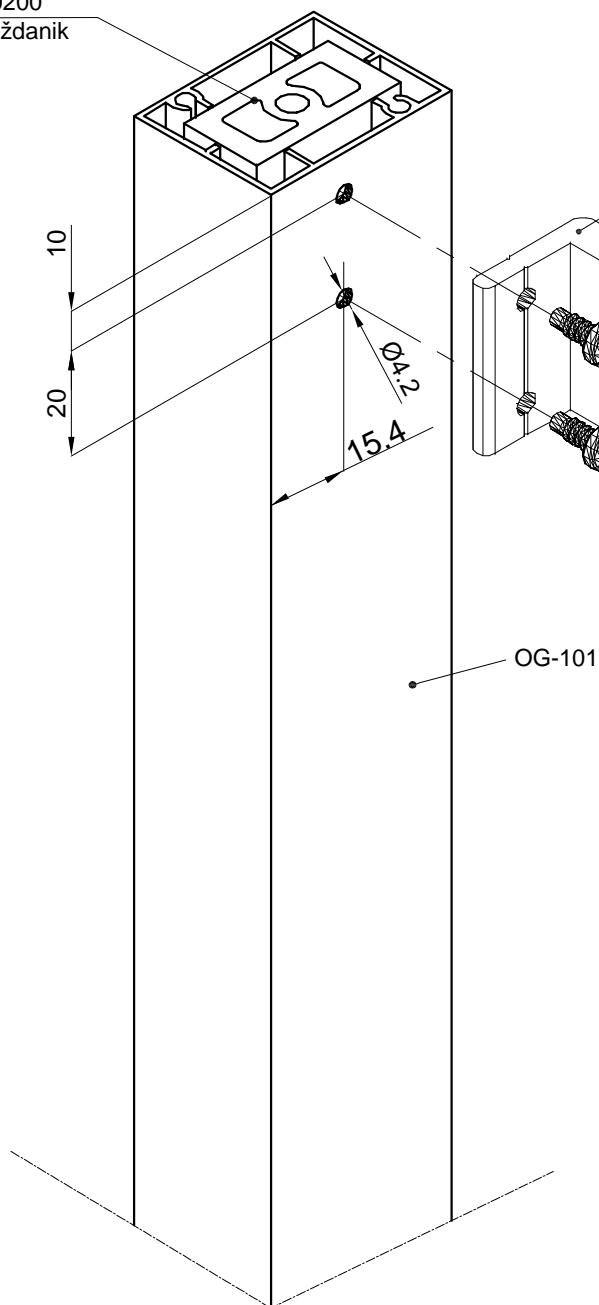

521.047 za(F-0174)
1 vijak 4.8x16 DIN7982
2 vijka 4.8x22 DIN7981

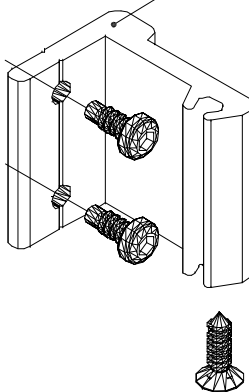

(F-0174-prečka pod rukohvatom),
spaja se preko veznika (521.047)
za al stub (OG101)

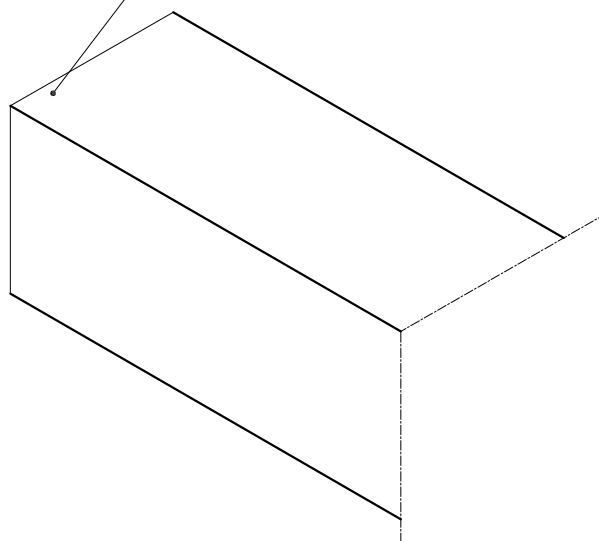

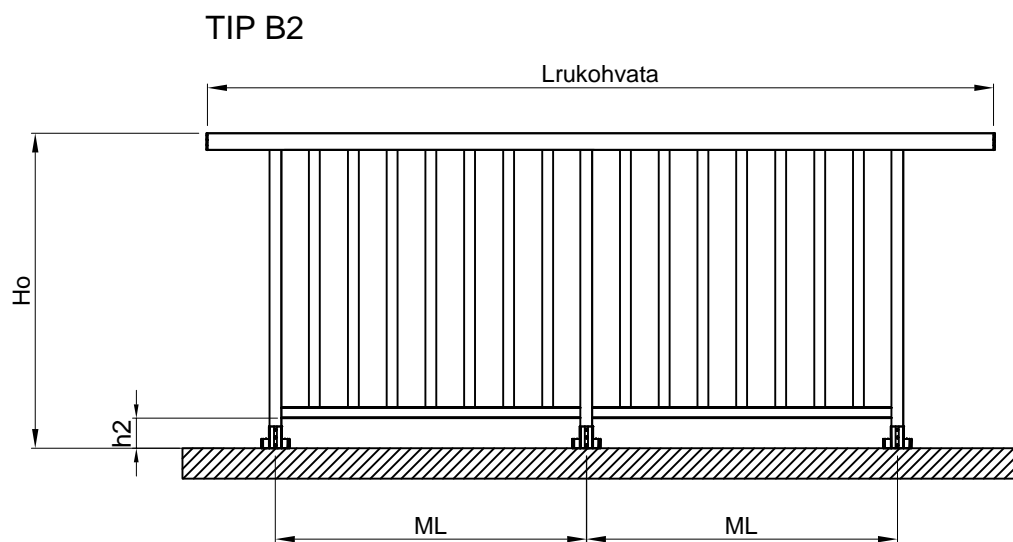
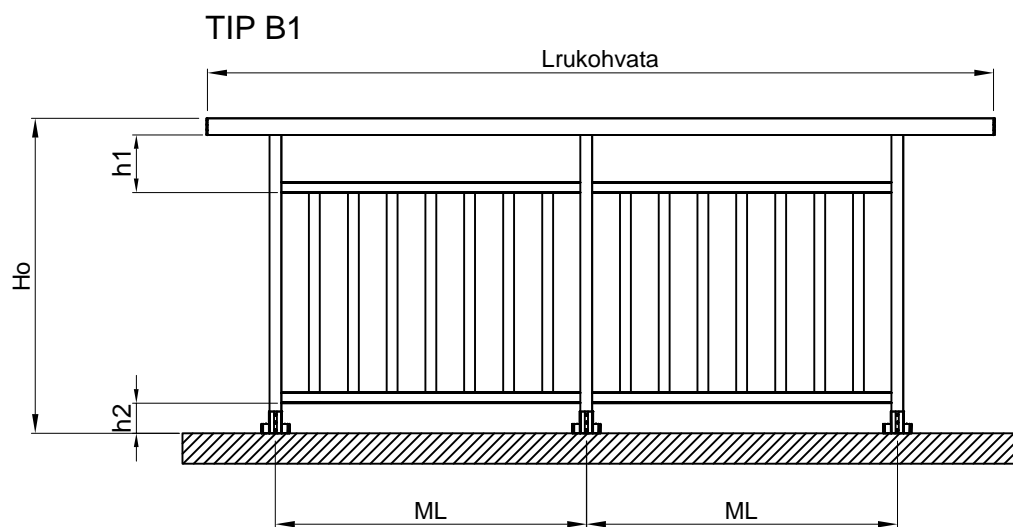

373.007 PVC
čep za rukohvat
F-0689

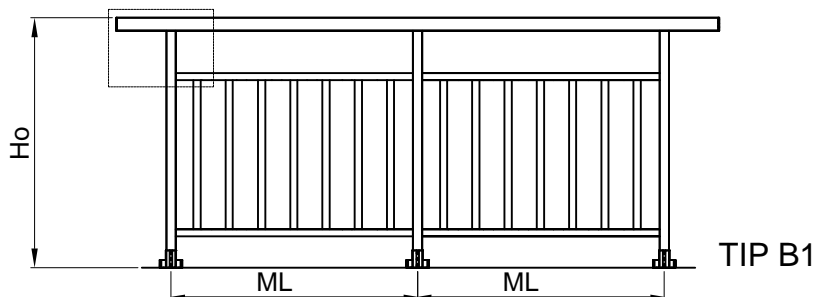

2 vijka 4.8x19 DIN7981
1 Vijak M8x30 DIN 933
za spajanje (F-0620)
podrukohvata sa
al. stubom (F-1246)

F-0689
(rukohvat)

F-0620
podrukohvat

F-0200
Moždanik

F-1246
Al Stub

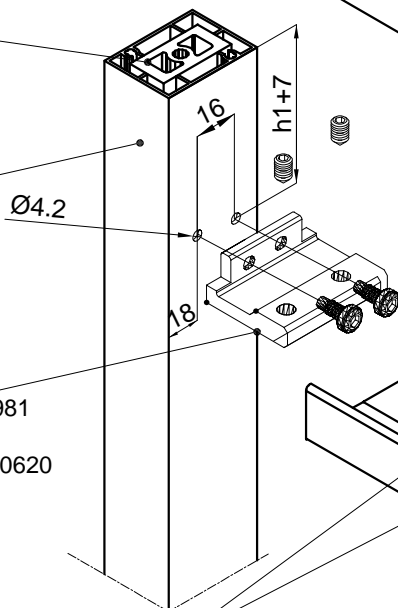

521.052
2 vijaka 4.8x19 DIN7981
2 vijka M 6x8 DIN914
Veznik za spajanje F-0620
sa al. stubom F-1246

Vijci 4.8x19 DIN7981
za spajanje (F-0620) sa
(OG-111)

OG-103

F-0620

OG-111

OG-111

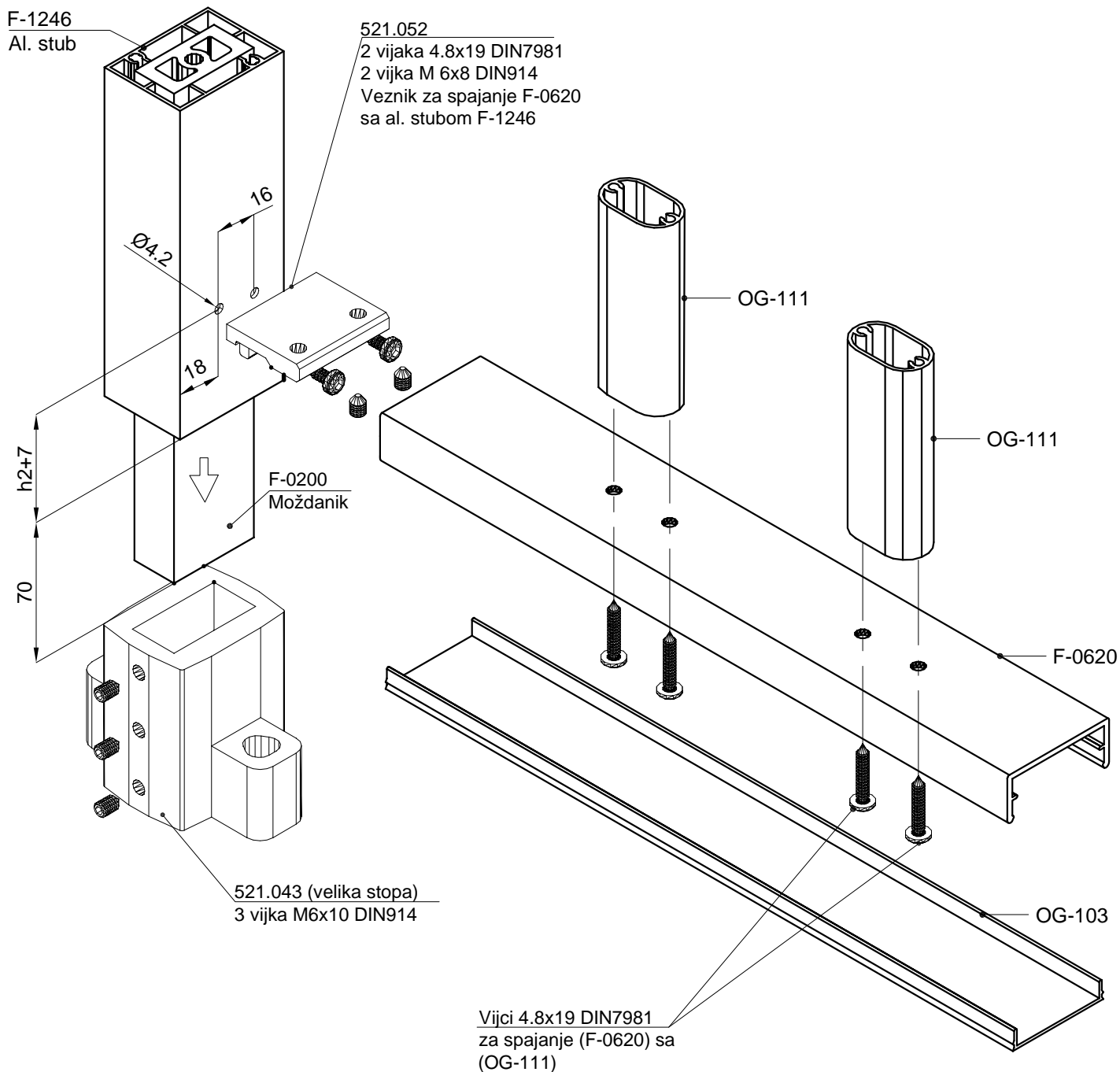
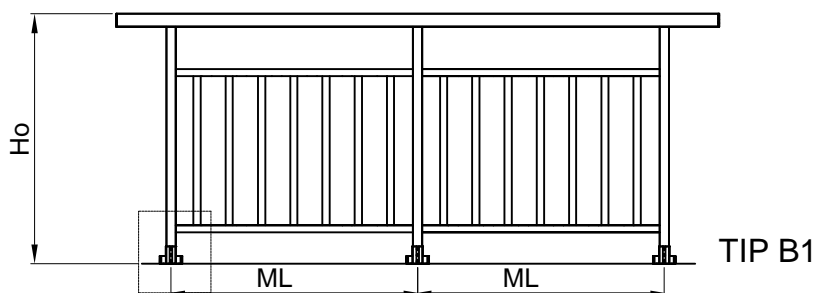

373.007 PVC
čep za rukohvat
F-0689

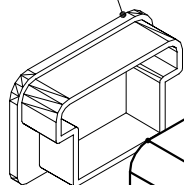

F-0689
(rukohvat)

2 vijka 4.8x19 DIN7981
1 Vijak M8x30 DIN 933
za spajanje (F-0620)
podrukohvata sa
al. stubom (F-1246)

F-0620
podrukohvat

F-0200
Moždanik

F-1246
Al. stub

Vijci 4.8x19 DIN7981
za spajanje (F-0620)
podrukohvata
sa (OG-111)

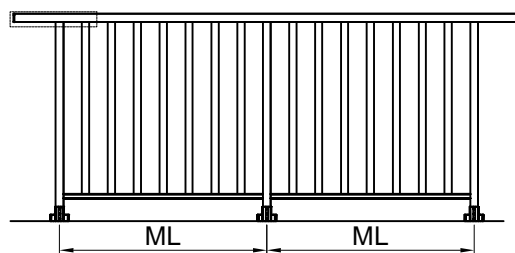

TIP B2

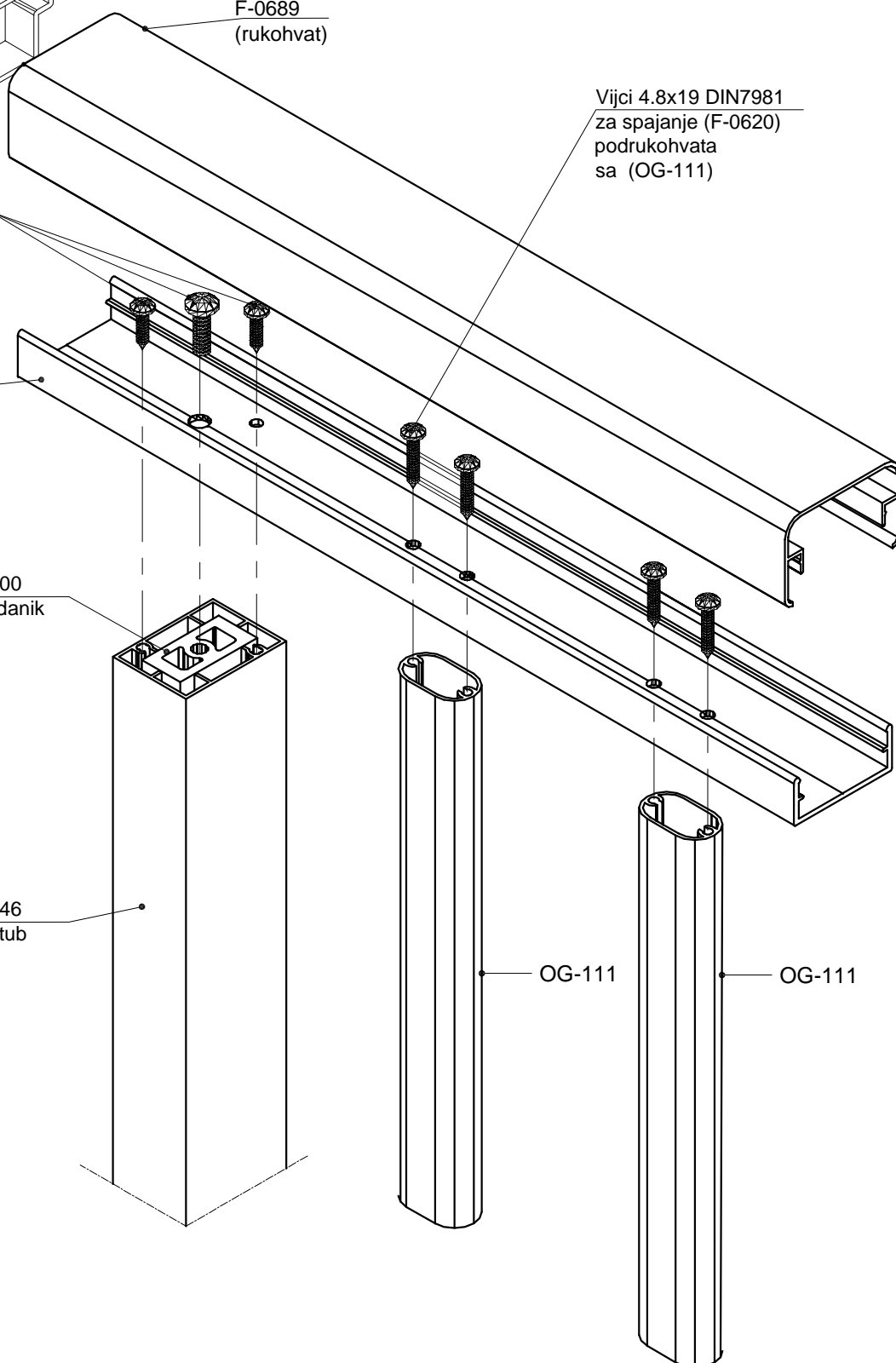

OG-111

OG-111

373.007 PVC
čep za rukohvat
F-0689

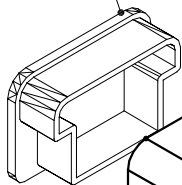

F-0689
(rukohvat)

2 vijka 4.8x19 DIN7981
1 Vijak M8x30 DIN 933
za spajanje (F-0620)
podrukohvata sa
al. stubom (F-1246)

F-0620
podrukohvat

F-0200
Moždanik

F-1246
Al. stub

F-1541
Ispuna

F-1451
Ispuna

Vijci 4.2x13 DIN7981
za spajanje (F-0620)
podrukohvata
sa (F-1451)

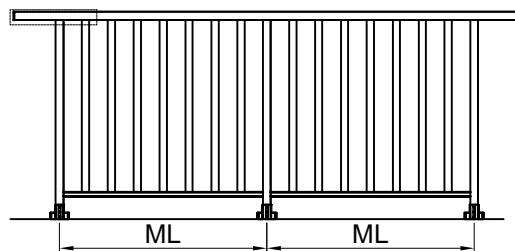

TIP B2

373.007 PVC
čep za rukohvat
F-0689

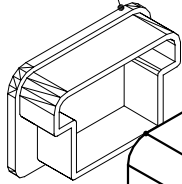

F-0689
(rukohvat)

2 vijka 4.8x19 DIN7981
1 Vijak M8x30 DIN 933
za spajanje (F-0620)
podrukohvata sa
al. stubom (F-1246)

F-0620
podrukohvat

F-0200
Moždanic

F-1246
Al. stub

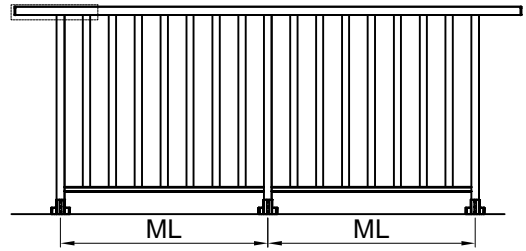

TIP B2

Vijci 4.2x13 DIN7981
za spajanje (F-0620)
podrukohvata
sa (F-1451)

F-1541
Ispuna

F-1451
Ispuna

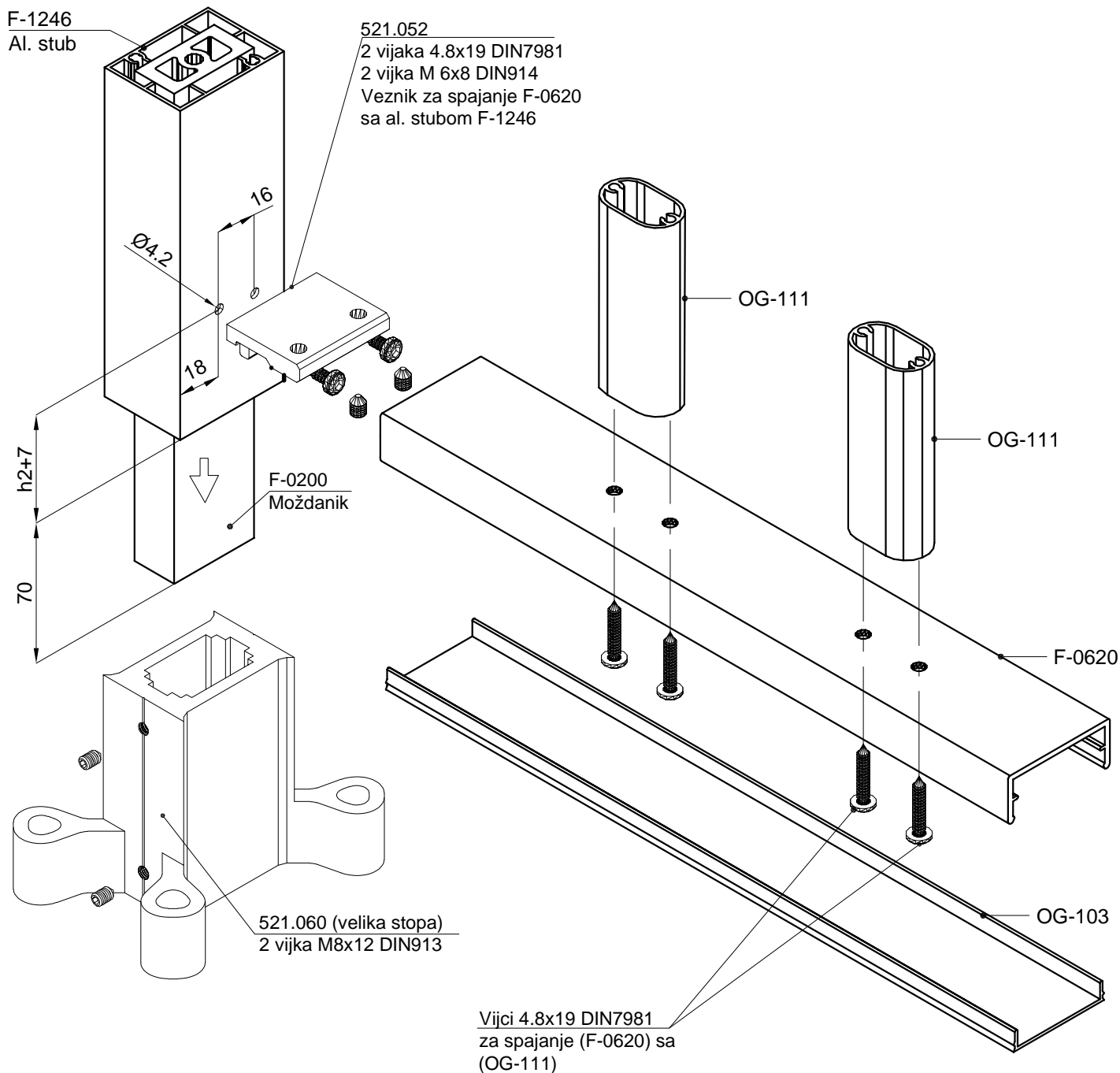
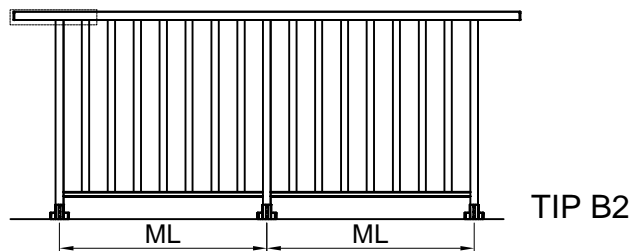

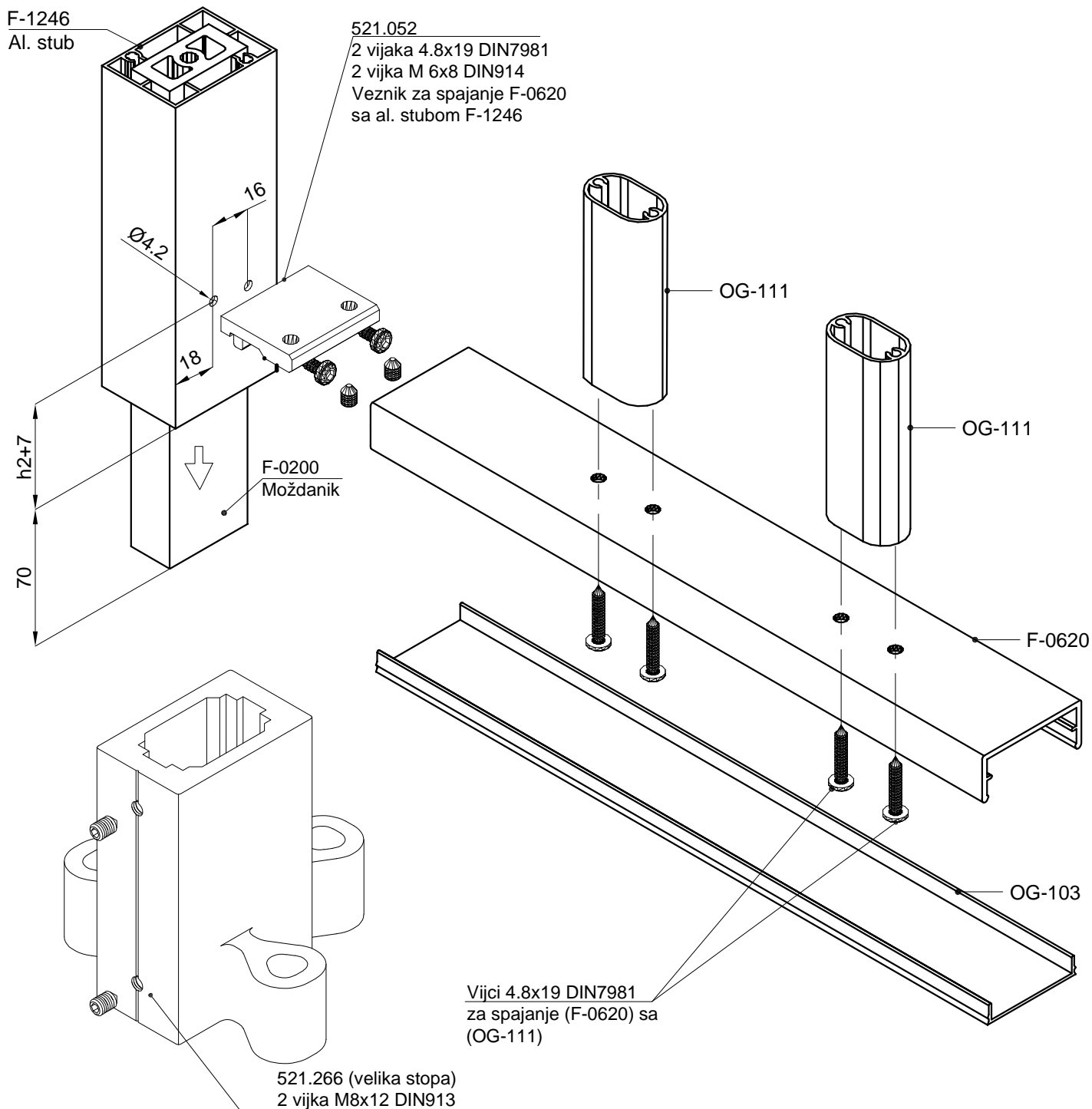
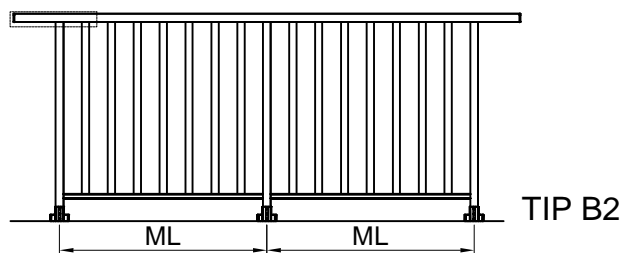

Držač stakla 521.082 /za staklo 55.2

TIP C1

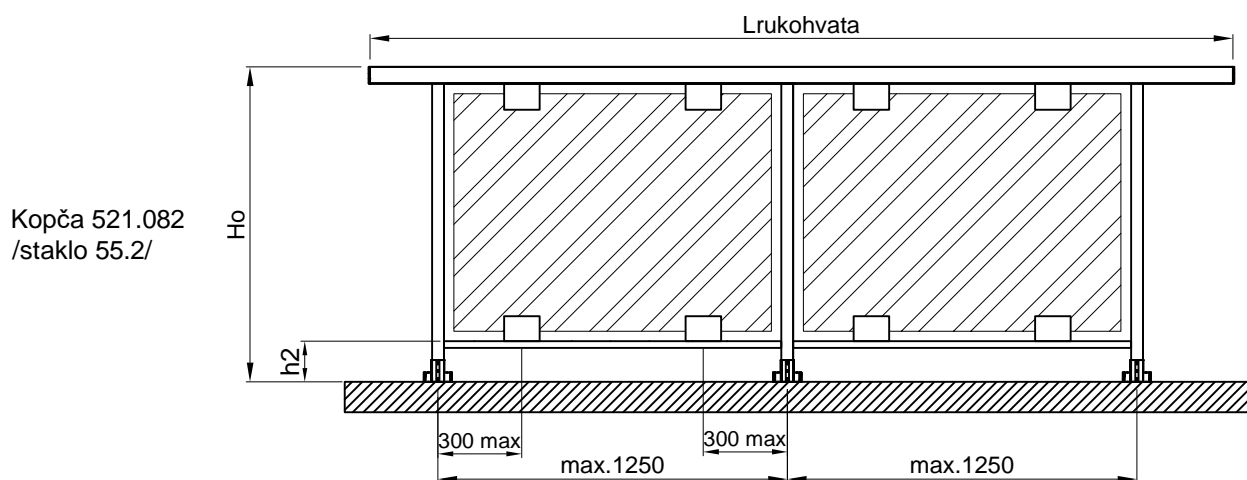

TIP C2

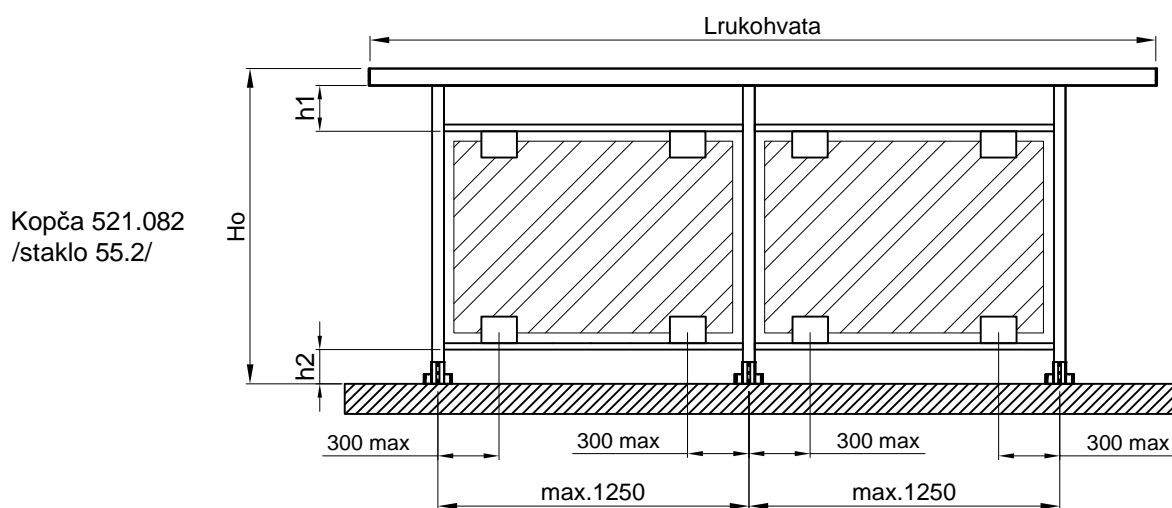

TIP C3

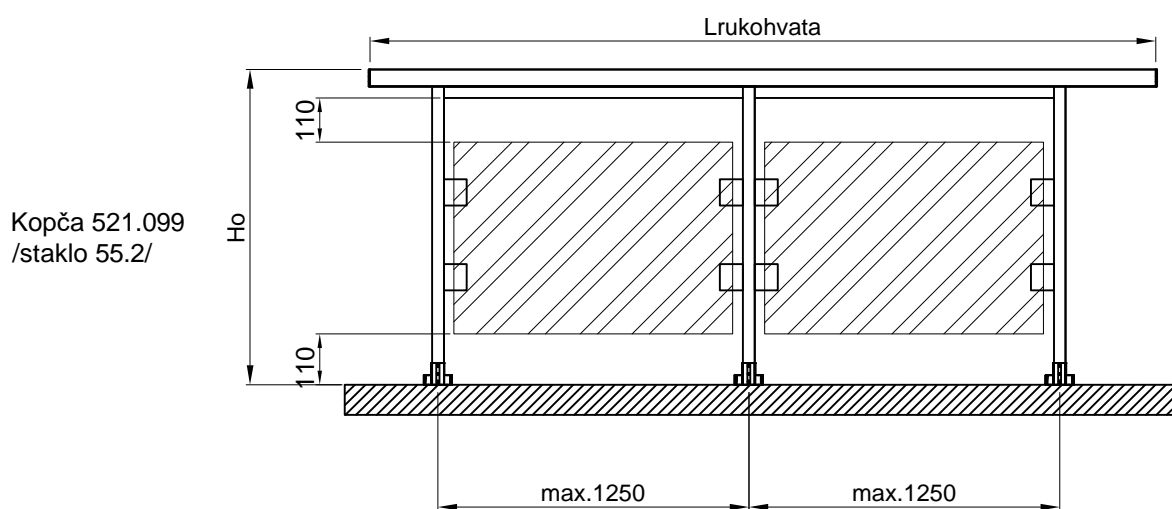

Držač stakla 521.082 /za staklo 55.2

TIP C4

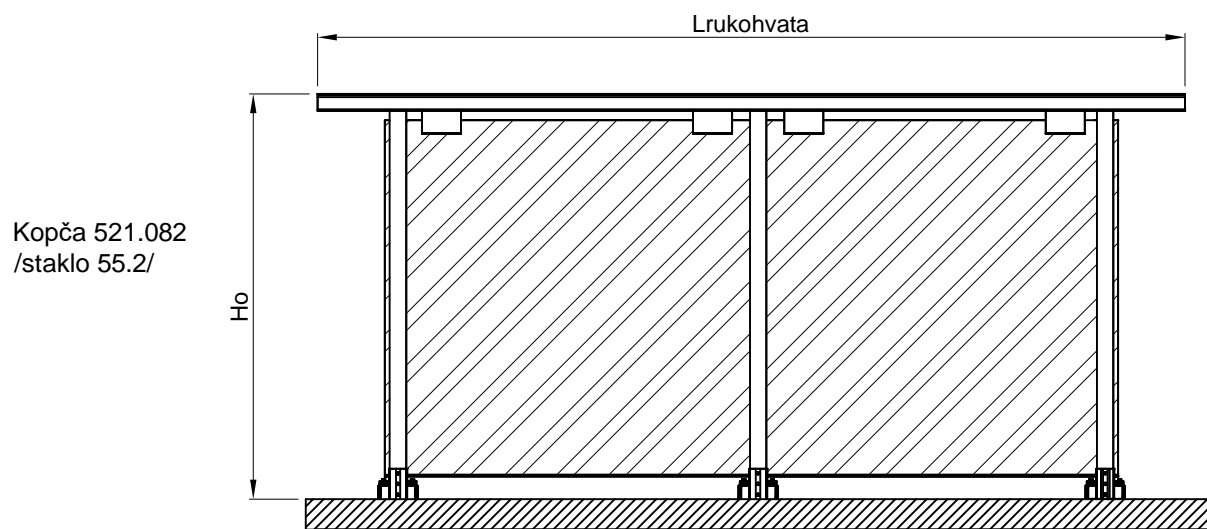

Staklena ograda sa kontinuiranom vodilicom (staklo 55.2)

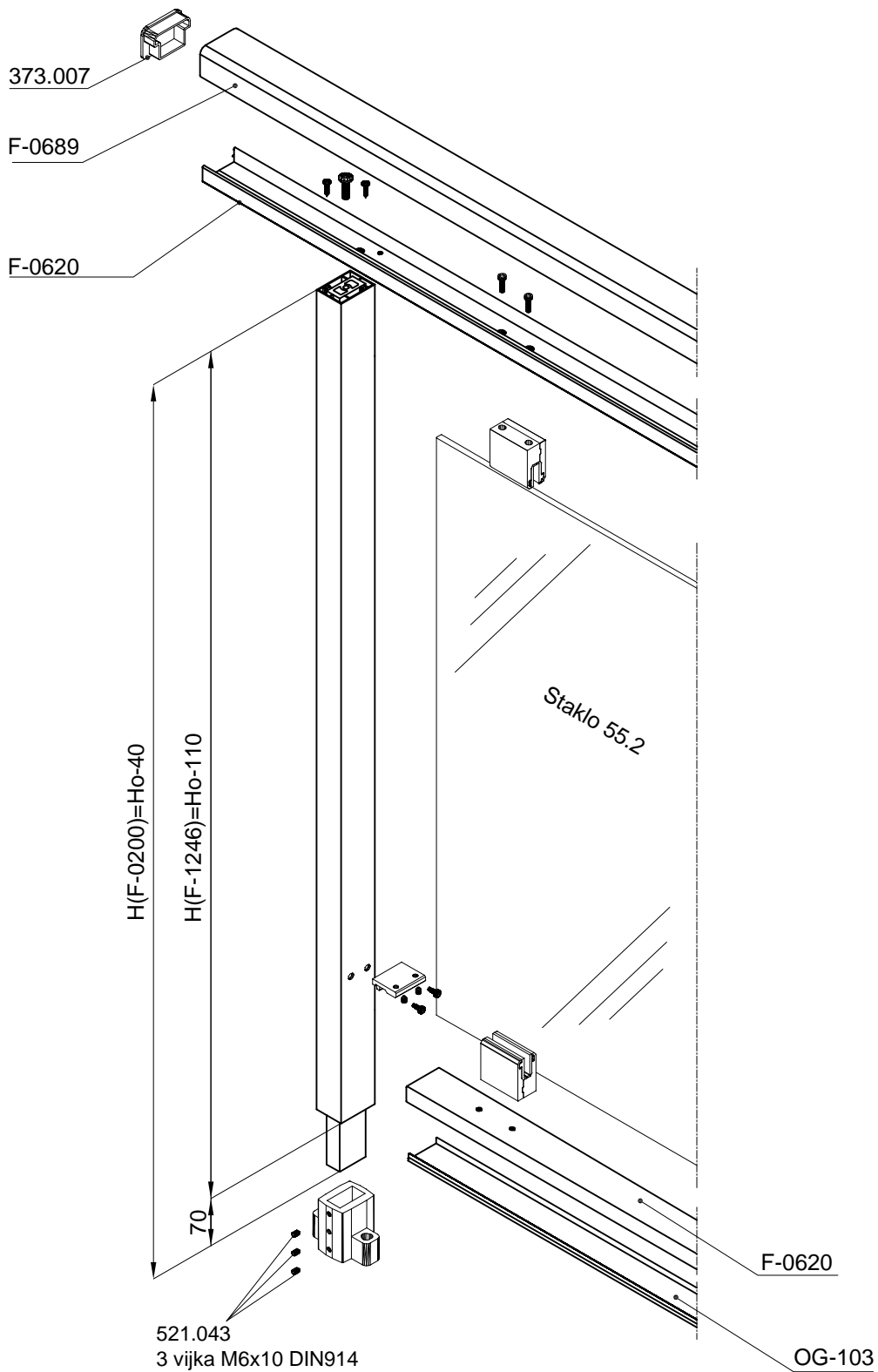
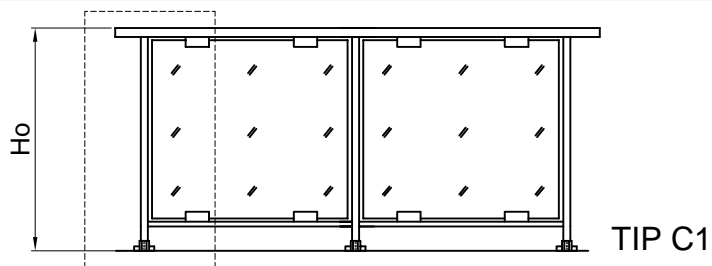

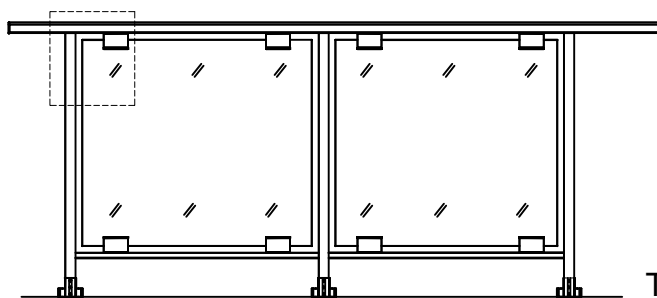

TIP C1

373.007 PVC
čep za rukohvat
F-0689

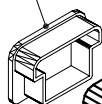

F-0689
Rukohvat

F-0620
Podrukohvat

2 vijka 4.8x19 DIN7981
1 Vijak M8x30 DIN 933
za spajanje (F-0620)
podrukohvata sa
al. stubom (F-1246)

Vijci M6x20 DIN6912
Za spajanje F-620 sa
držačem stakla 521.045

Držač stakla ravni; 521.082
koristi se za staklo 55.2
2 vijka M6x20 DIN 6912
2 vijka M5x20 DIN 7991

F-1246
Al. stub

Staklo 55.2

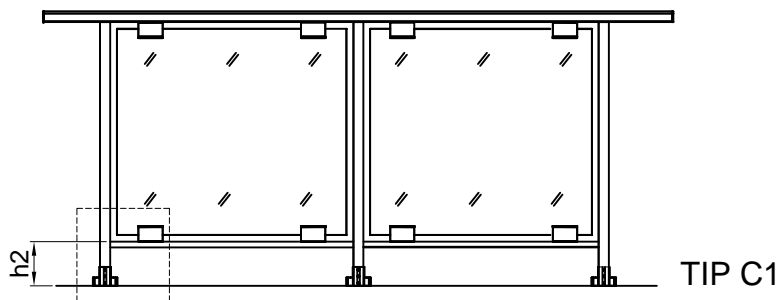

F-1246

521.052
2 vijaka 4.8x19 DIN7981
2 vijka M 6x8 DIN914
Veznik za spajanje F-0620
sa al. stubom F-1246

Staklo 55.2

Držač stakla ravni; 521.082
koristi se za staklo 55.2
2 vijka M6x20 DIN 6912
2 vijka M5x20 DIN 7991

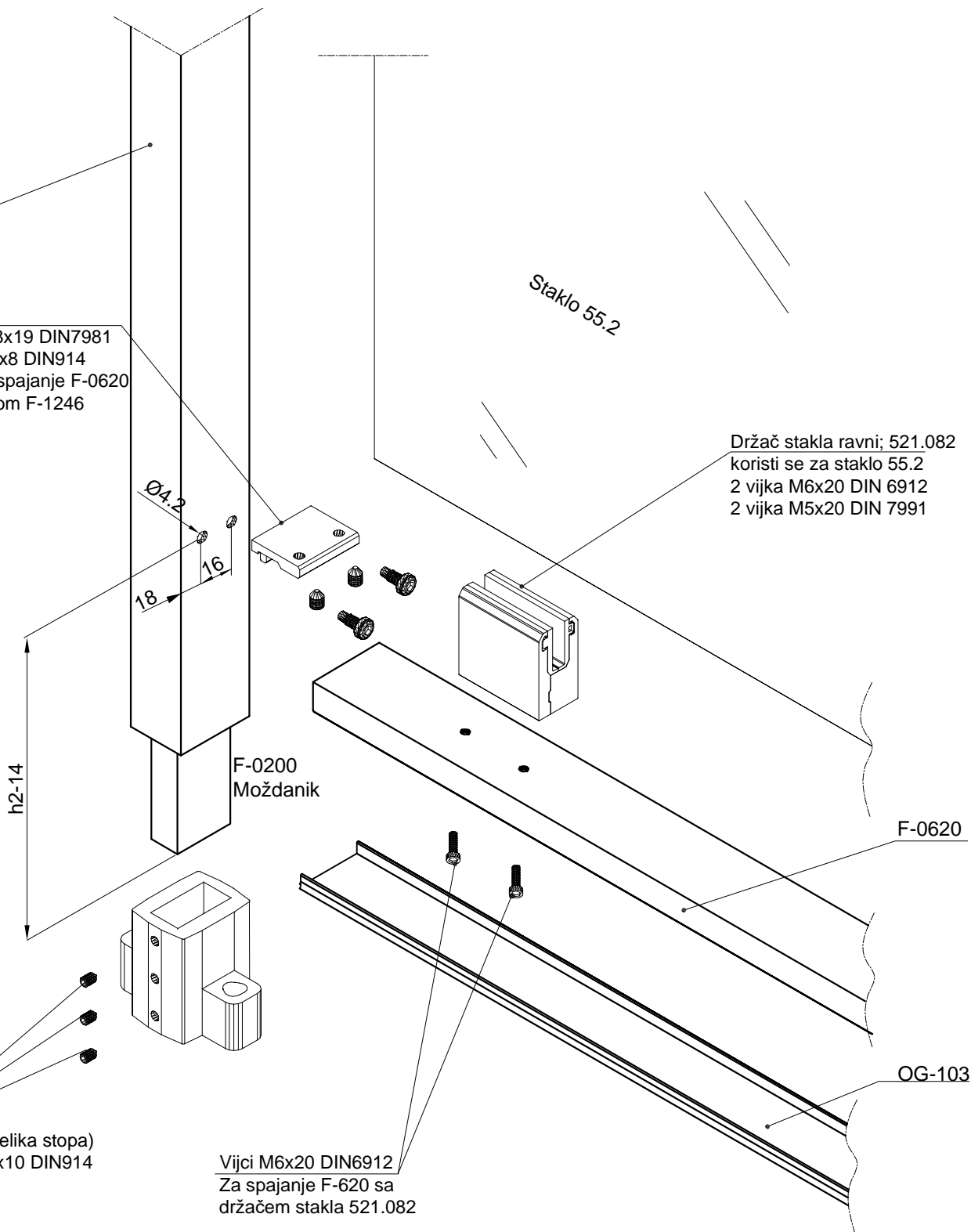

F-0200
Moždanik

F-0620

OG-103

521.043 (velika stopa)
3 vijka M6x10 DIN914

Vijci M6x20 DIN6912
Za spajanje F-620 sa
držačem stakla 521.082

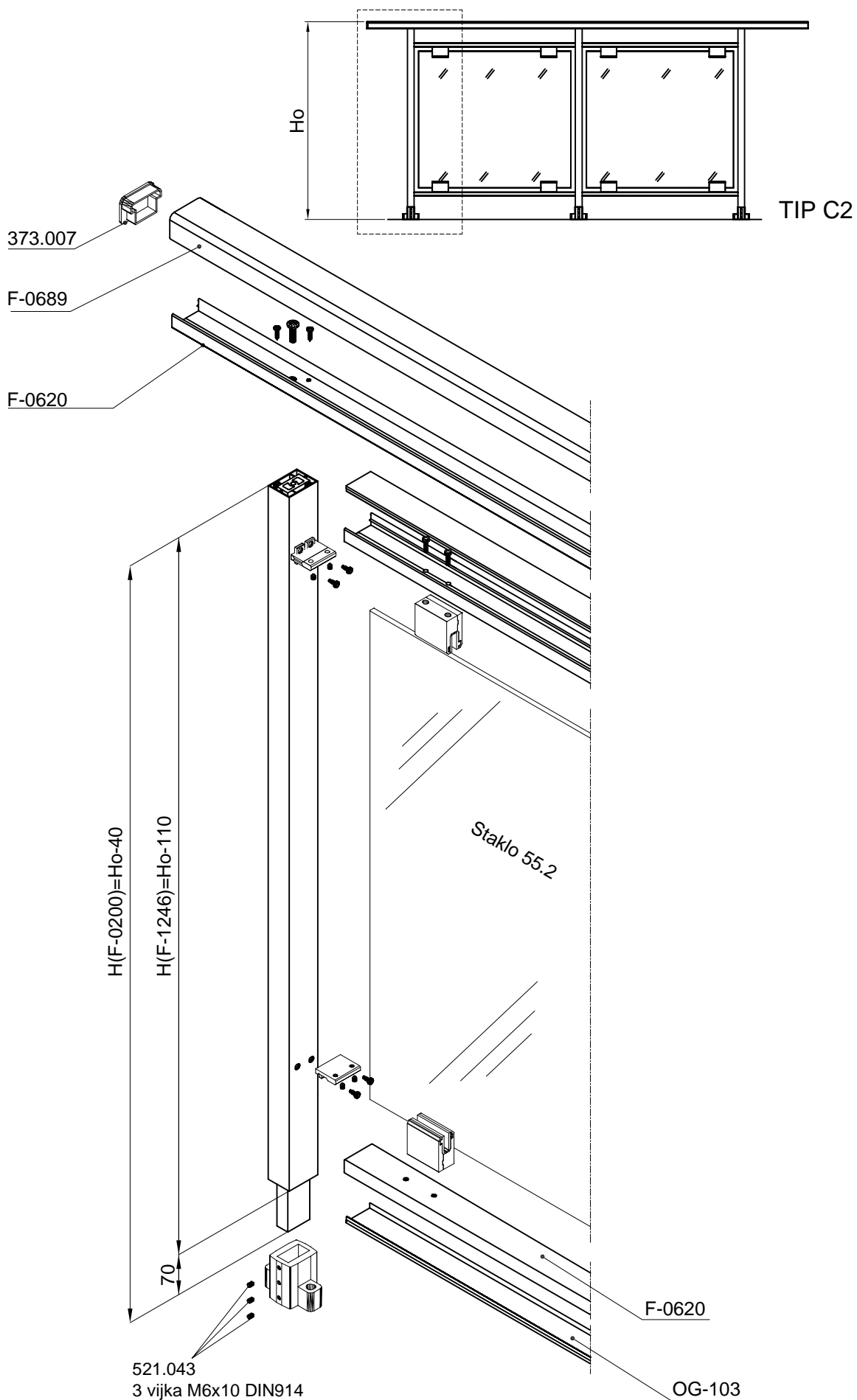

373.007 PVC
čep za rukohvat
F-0689

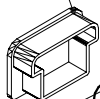

F-0689
Rukohvat

F-0620
podrukohvat

2 vijka 4.8x19 DIN7981
1 Vijak M8x30 DIN 933
za spajanje (F-0620)
podrukohvata sa
al. stubom (F-1246)

521.052
2 vijaka 4.8x19 DIN7981
2 vijka M 6x8 DIN914
Veznik za spajanje F-0620
sa al. stubom F-1246

Vijci M6x20 DIN6912
Za spajanje F-620 sa
držačem stakla 521.082

Držač stakla ravni; 521.082
koristi se za staklo 55.2
2 vijka M6x20 DIN 6912
2 vijka M5x20 DIN 7991

F-1246
Al. stub

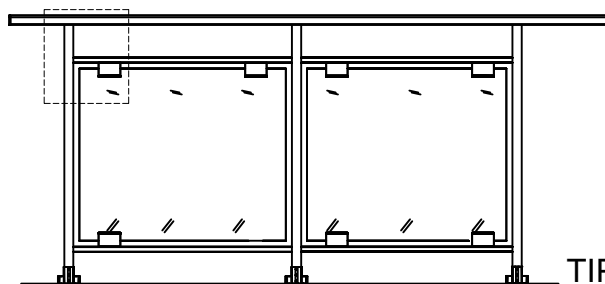

TIP C2

OG-10:

F-0620

Staklo 55.2

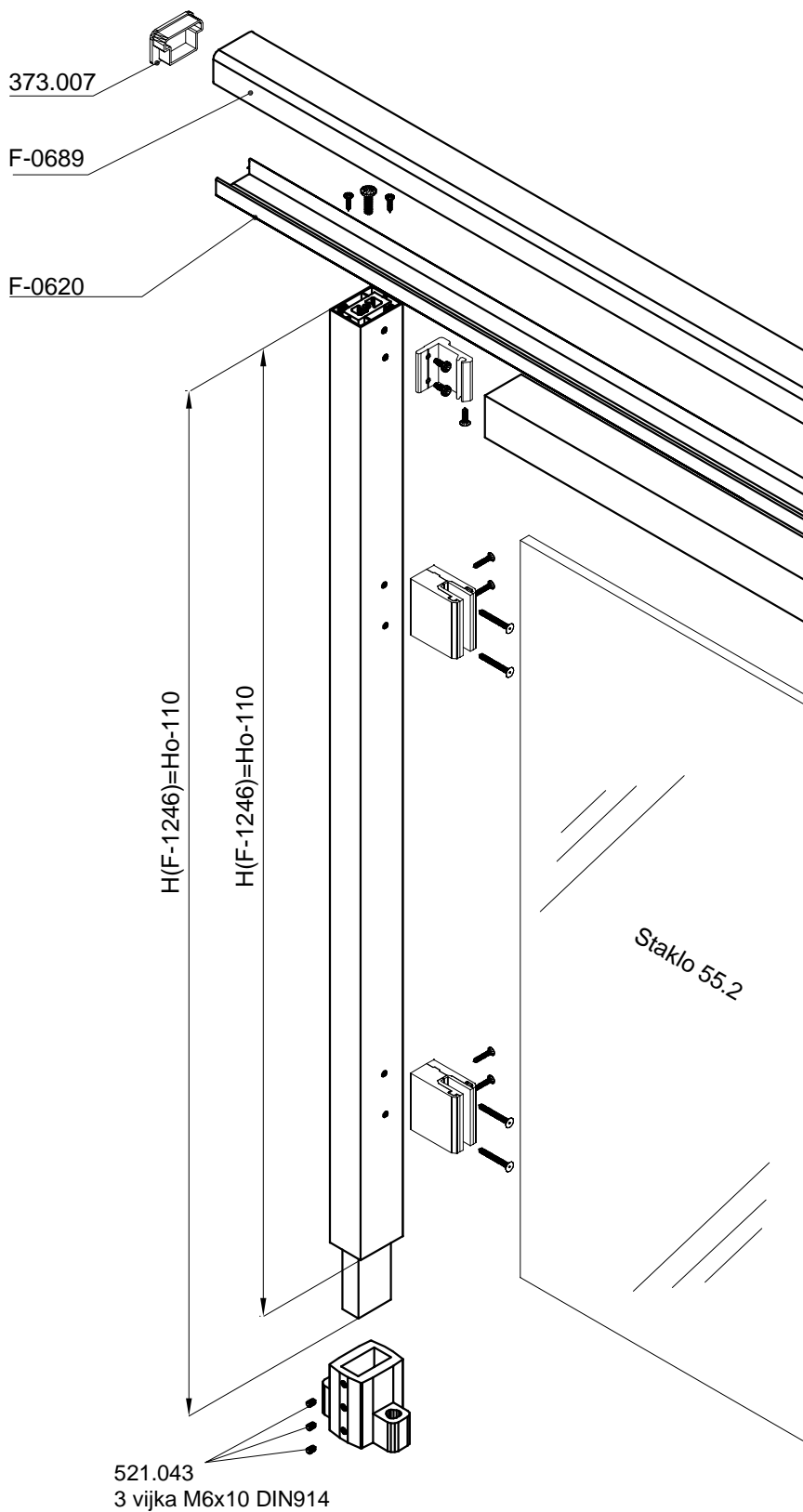
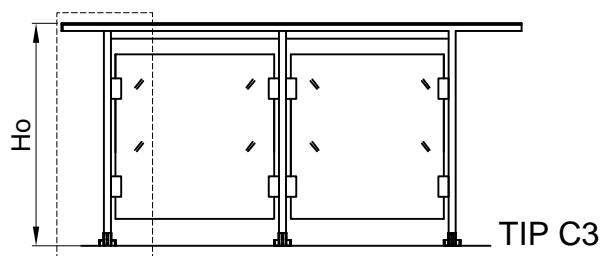

373.007 PVC
čep za rukohvat
F-0689

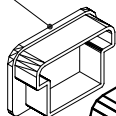

2 vijka 4.8x19 DIN7981
1 Vijak M8x30 DIN 933
za spajanje (F-0620)
podrukhovata sa
al. stubom (F-1246)

521.047 za(F-0174)
1 vijak 4.8x16 DIN7982
2 vijka 4.8x22 DIN7981

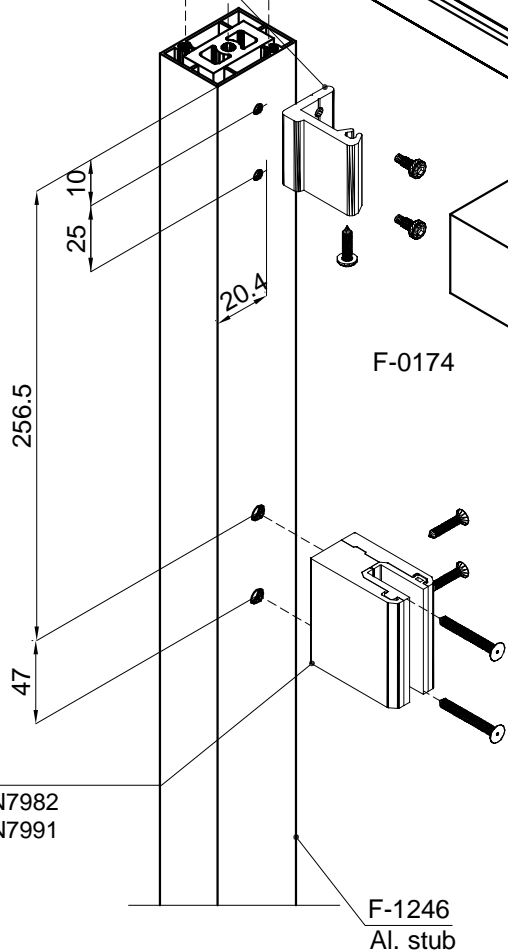

521.099
2 vijak 4.8x38 DIN7982
2 vijka M5x20 DIN7991

F-1246
Al. stub

Staklo 55.2

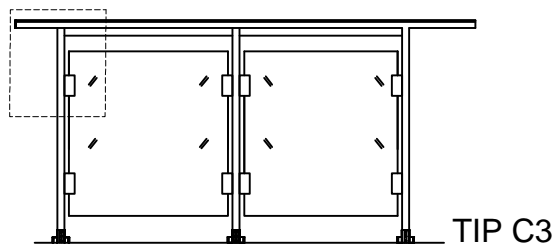

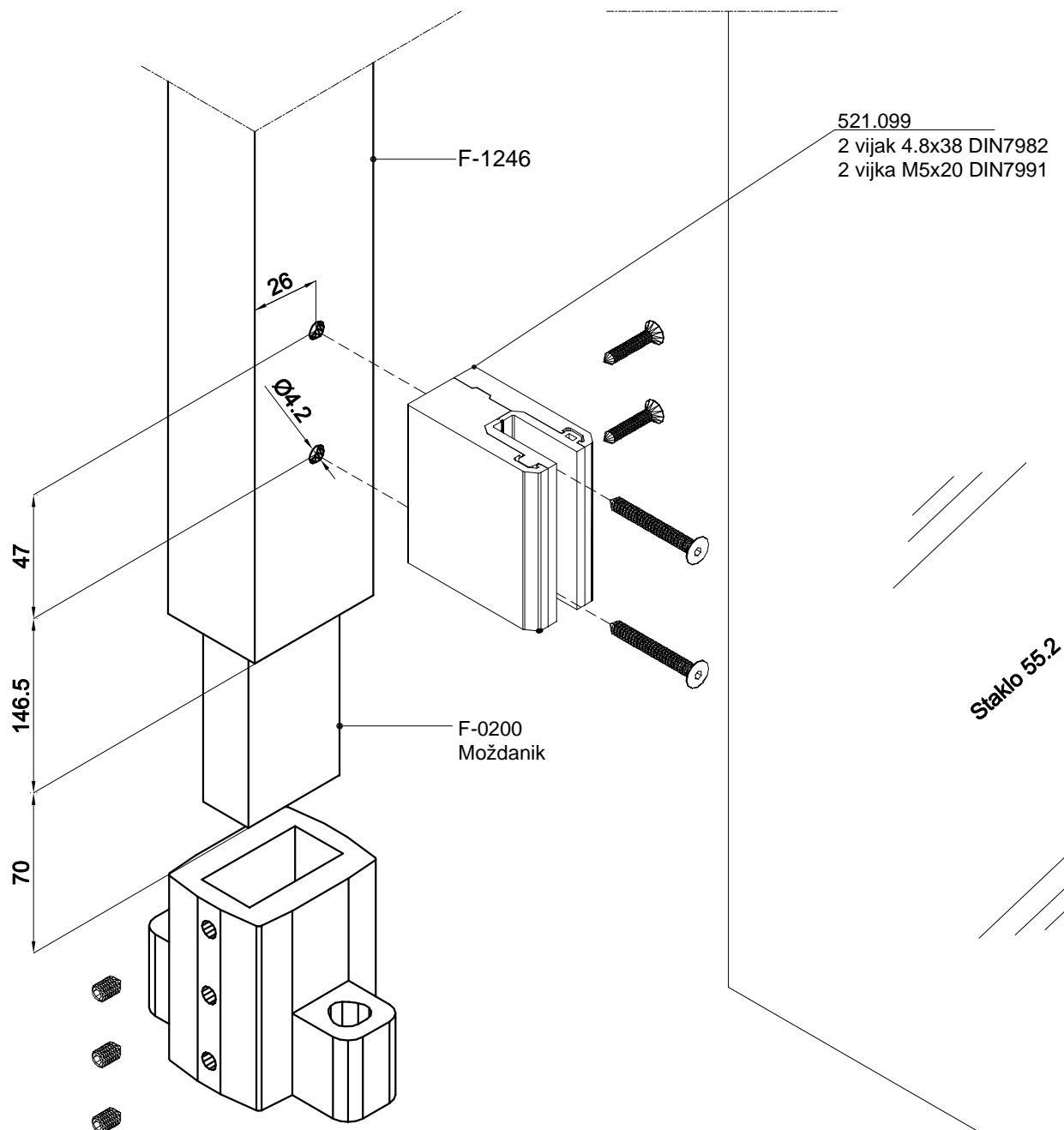
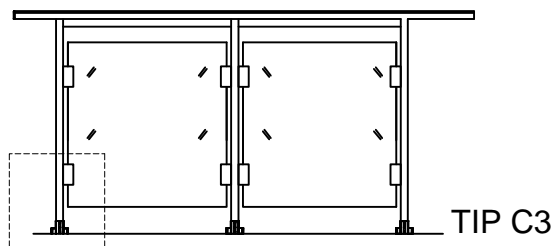

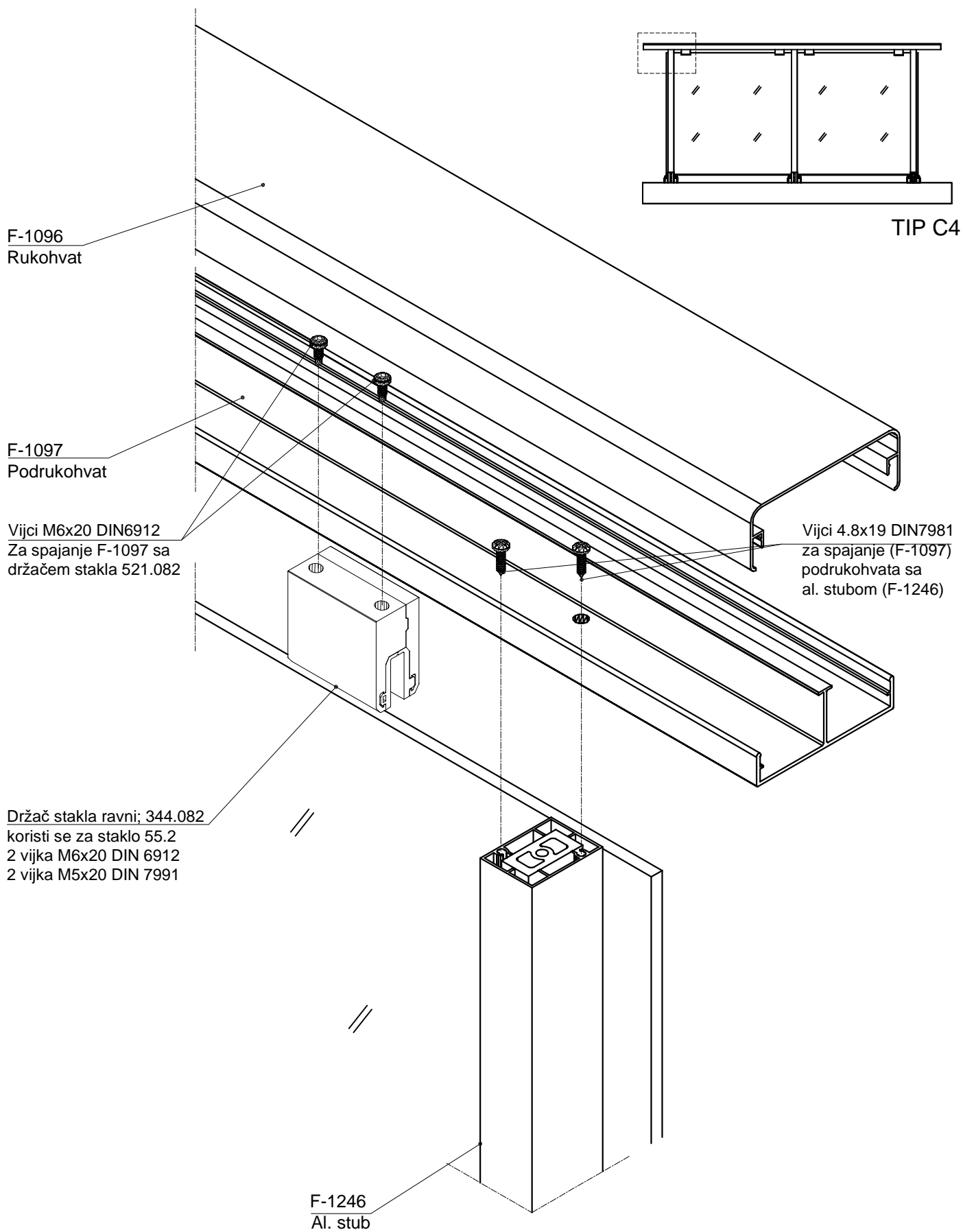

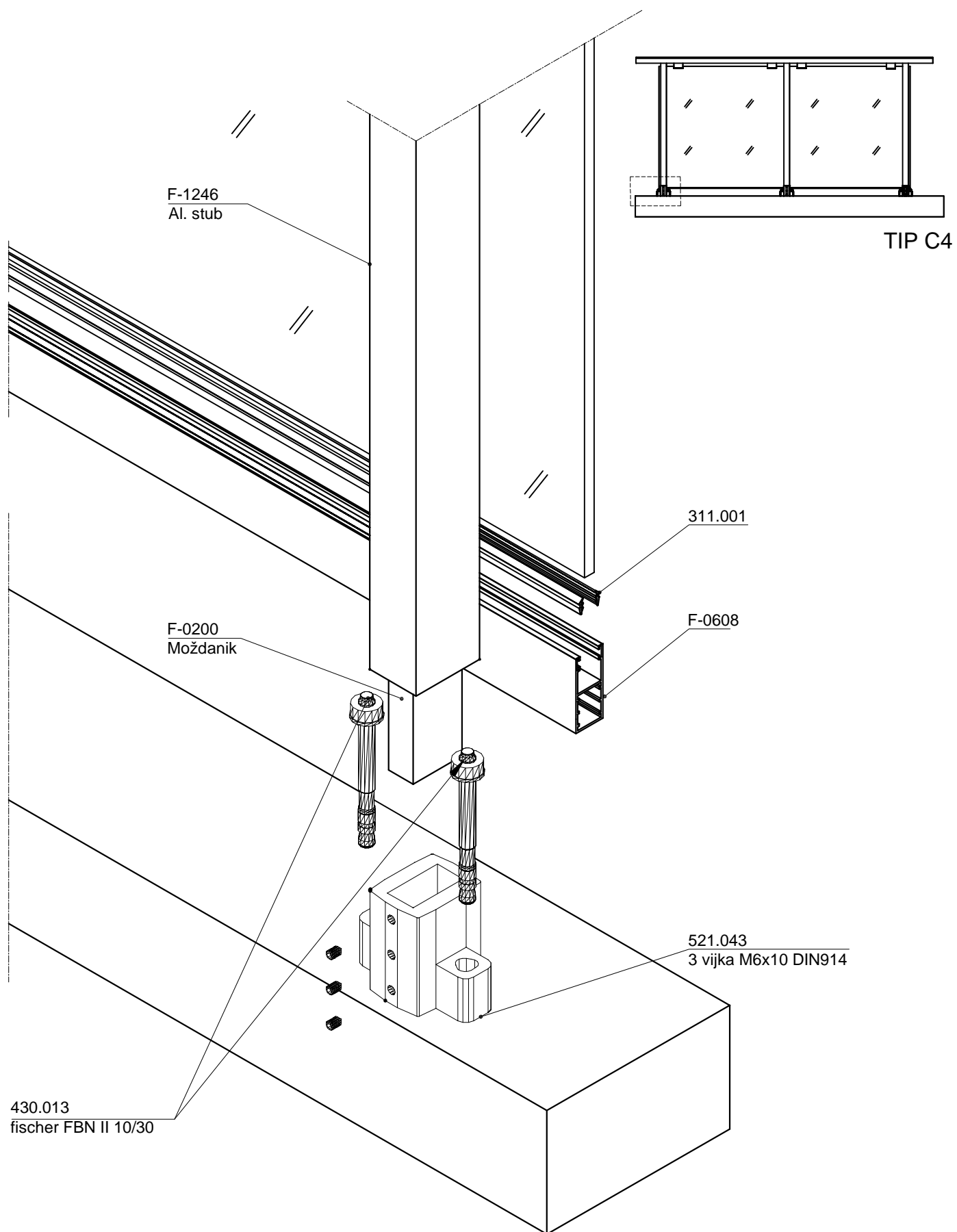

Držač stakla 521.045 /za staklo 44.2

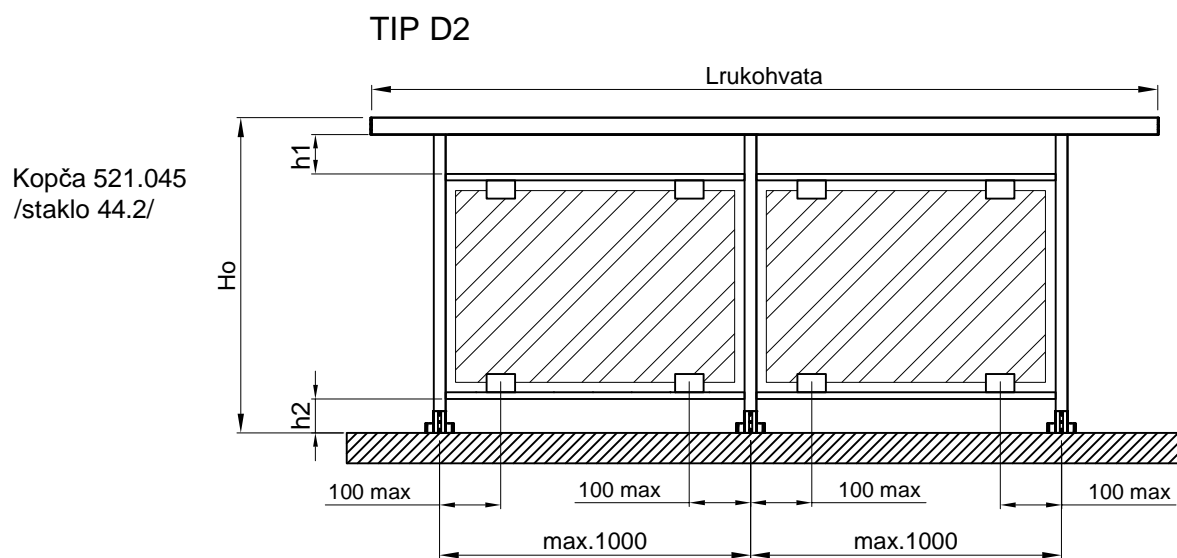
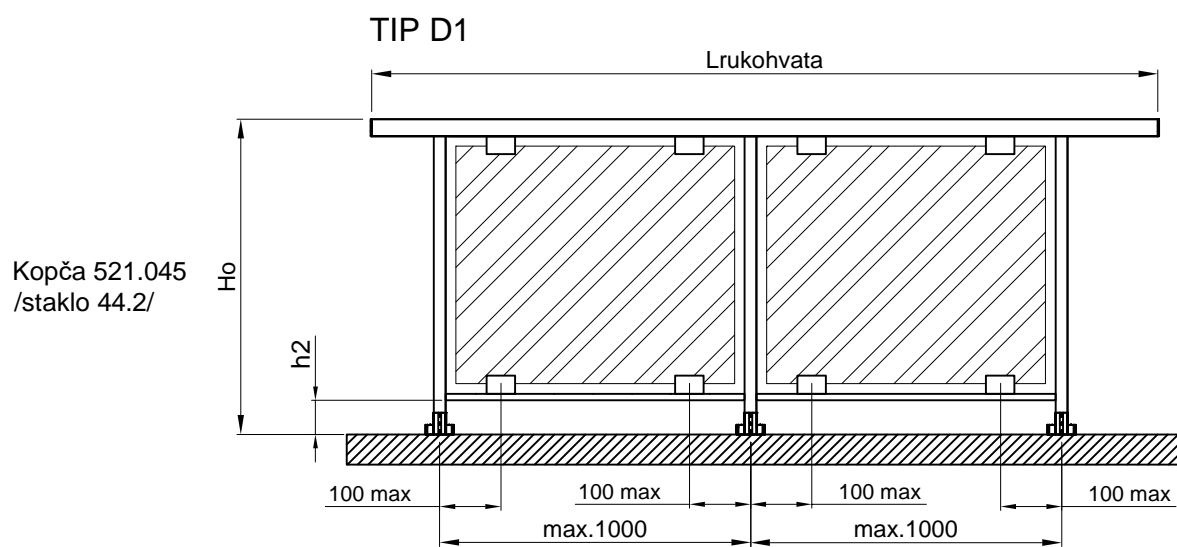

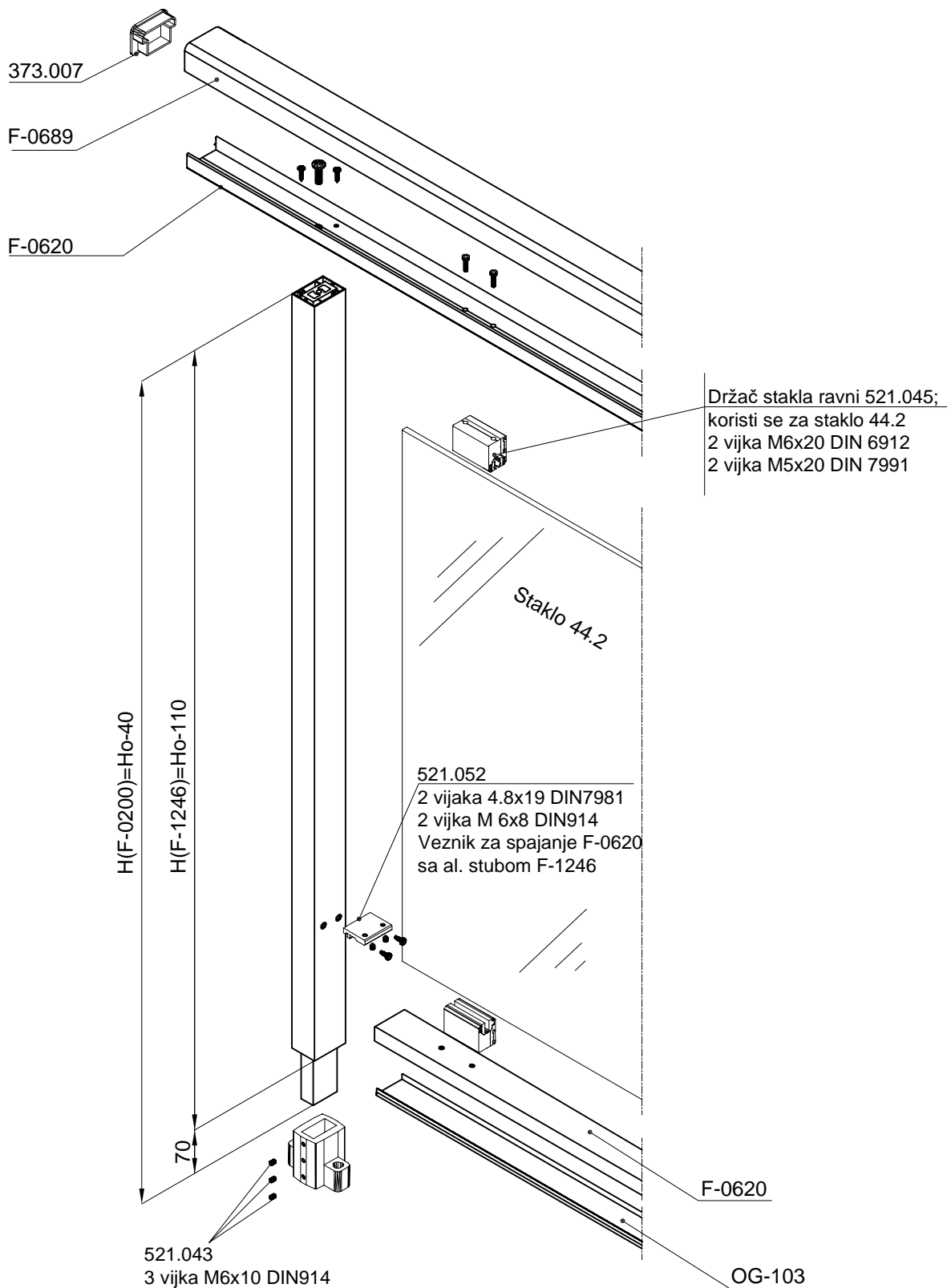
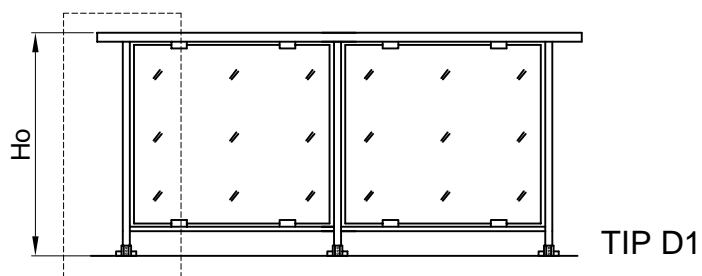

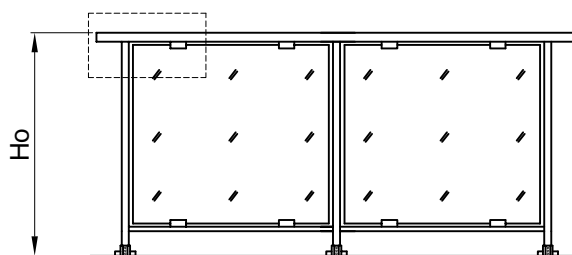

TIP D1

373.007 PVC
čep za rukohvat
F-0689

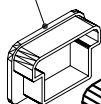

F-0689
Rukohvat

F-0620
Podrukohvat

2 vijka 4.8x19 DIN7981
1 Vijak M8x30 DIN 933
za spajanje (F-0620)
podrukohvata sa
al. stubom (F-1246)

Držač stakla ravni 521.045
koristi se za staklo 44.2
2 vijka M6x20 DIN 6912
2 vijka M5x20 DIN 7991

Vijci M6x20 DIN6912
Za spajanje F-620 sa
držačem stakla 521.045

F-1246
Al. stub

Staklo 44.2

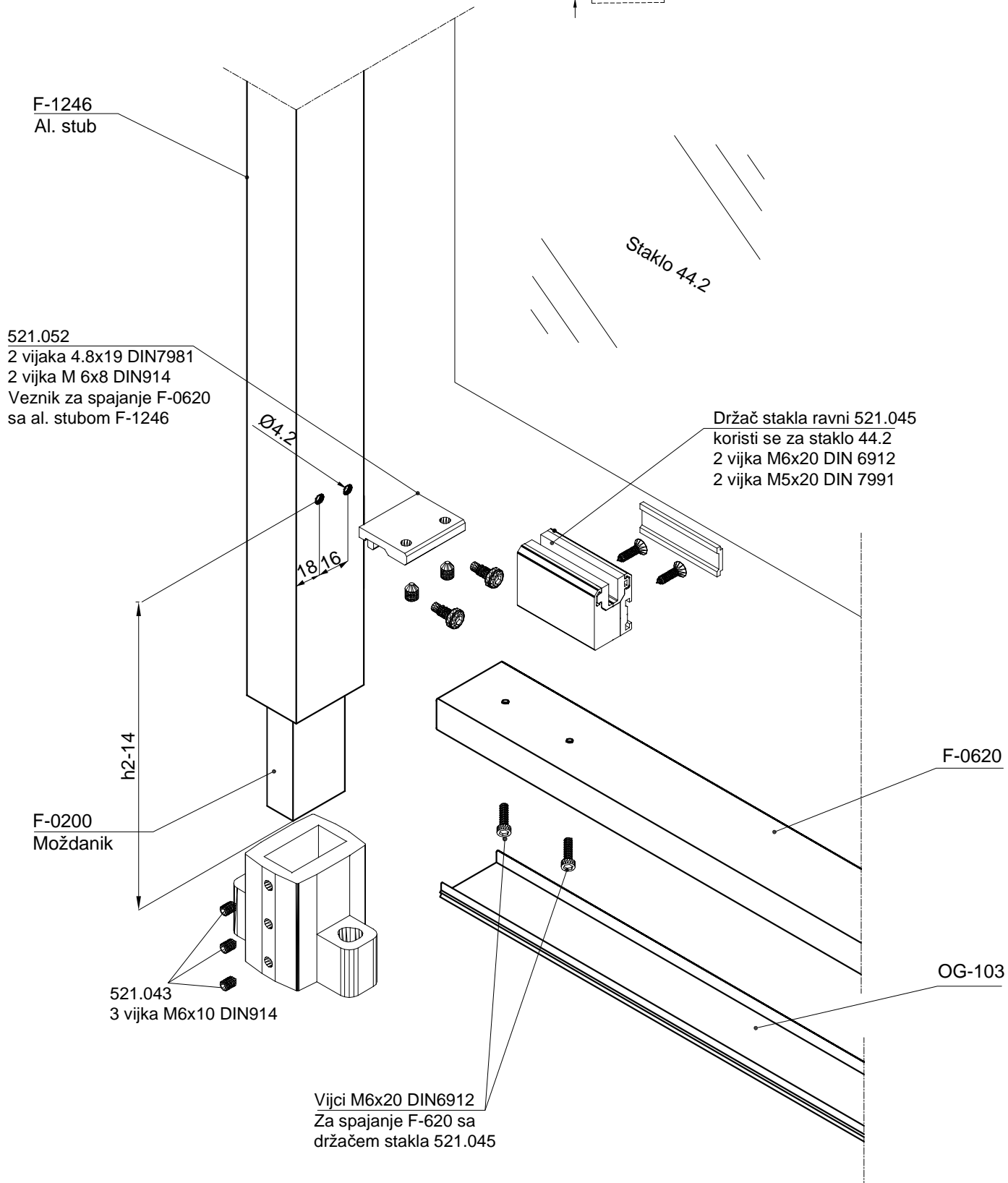
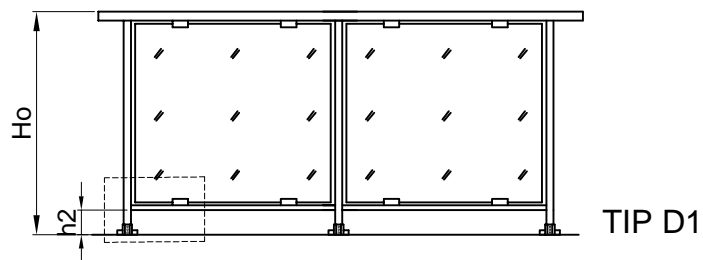

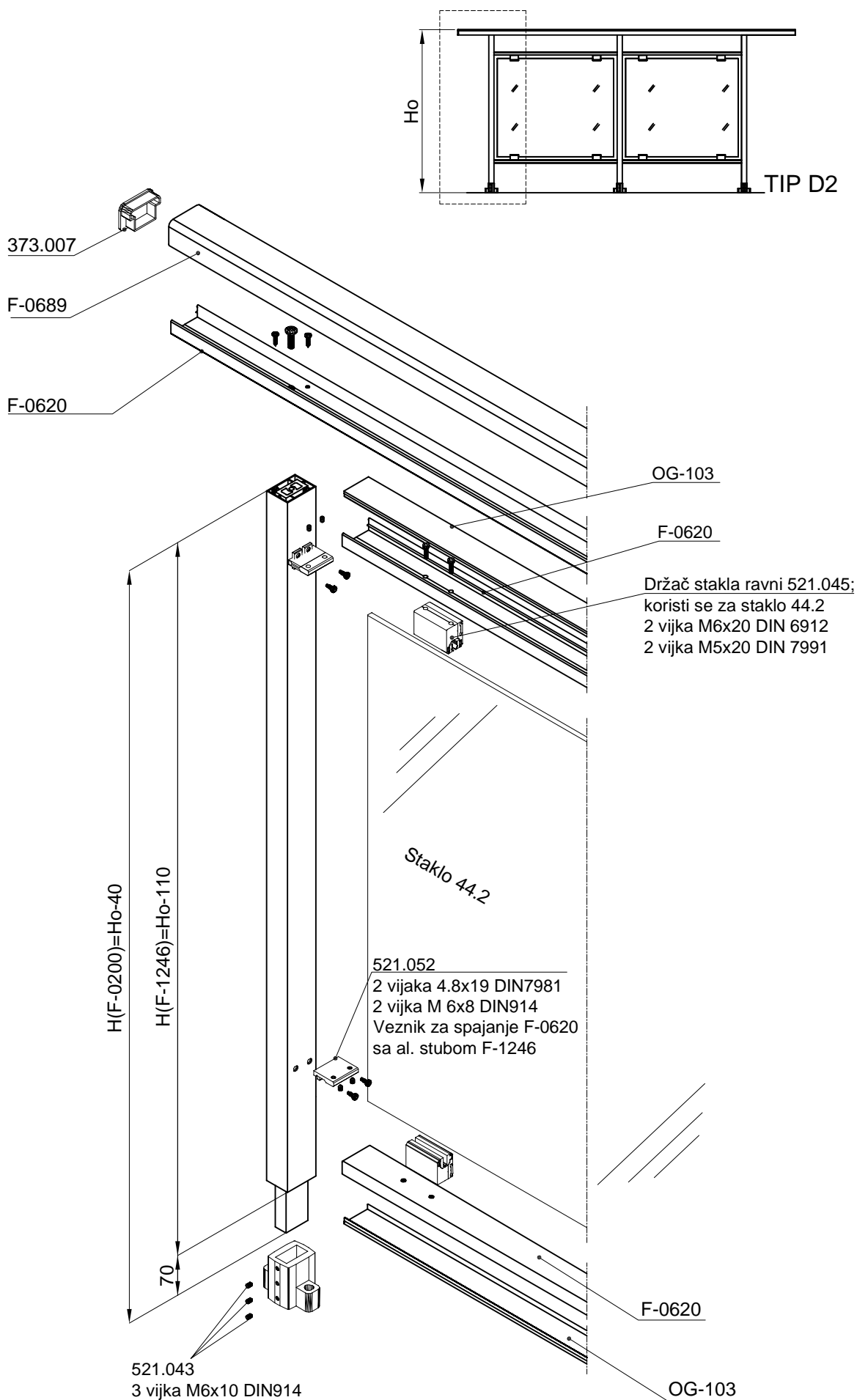

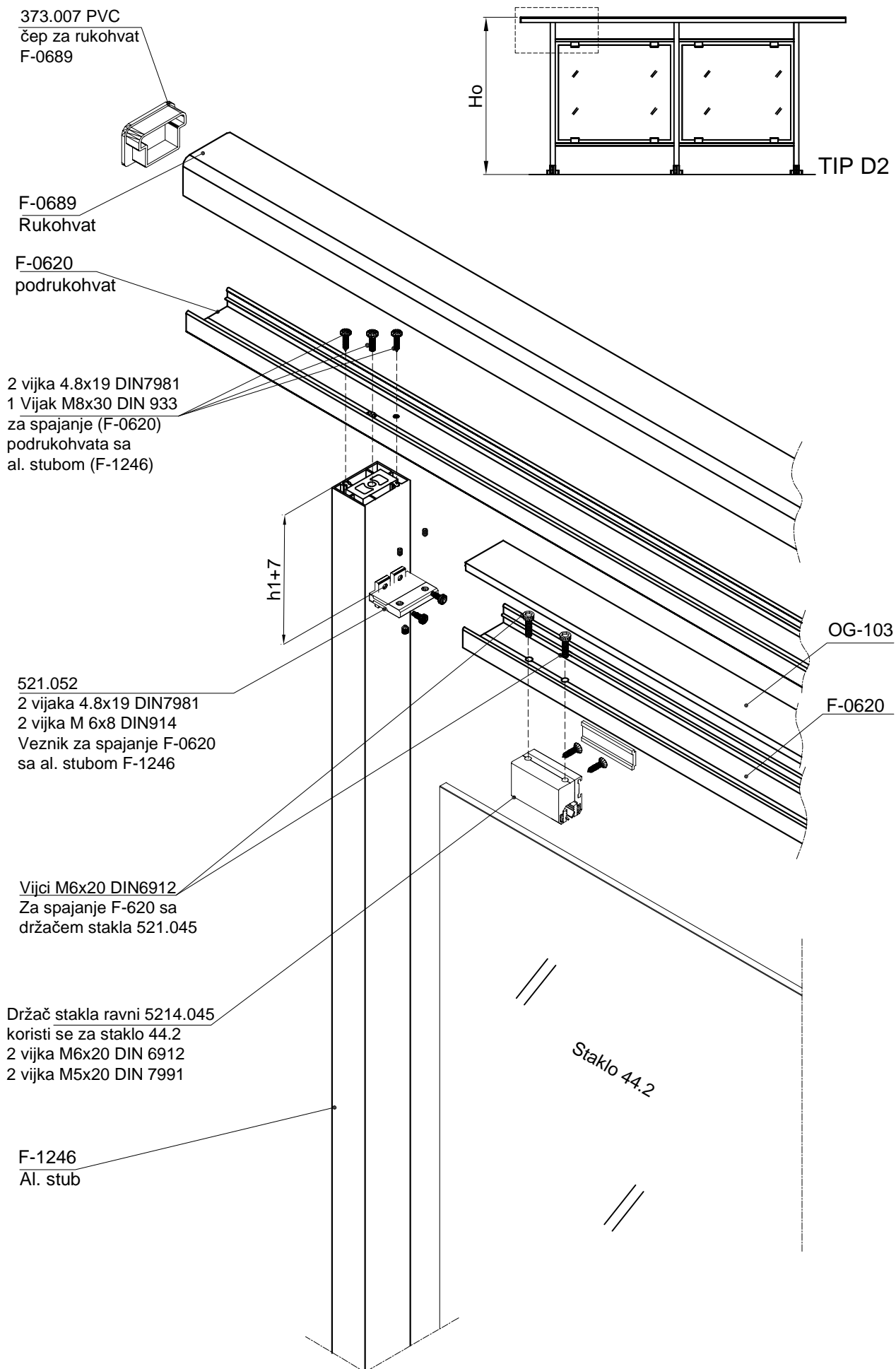

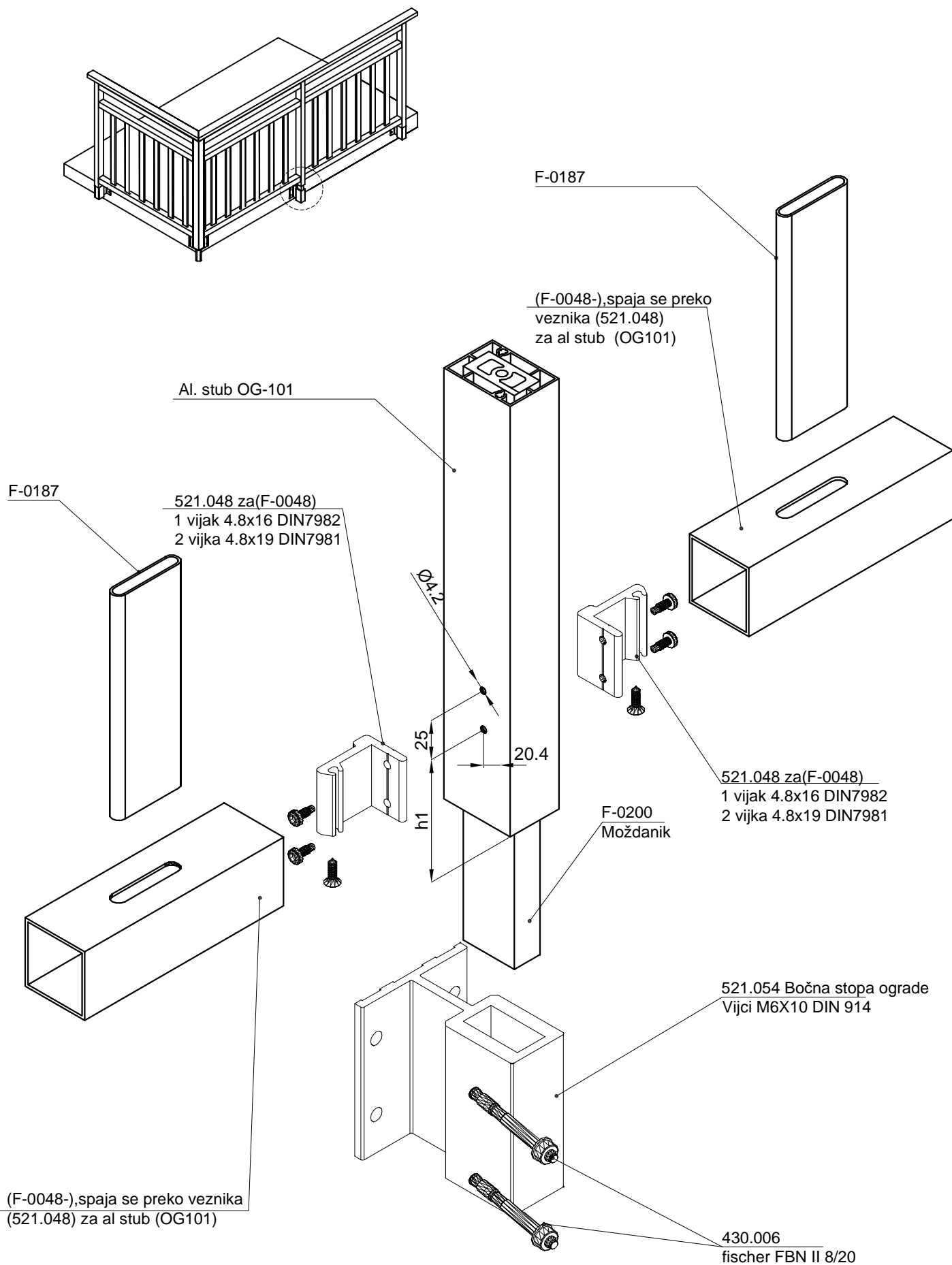

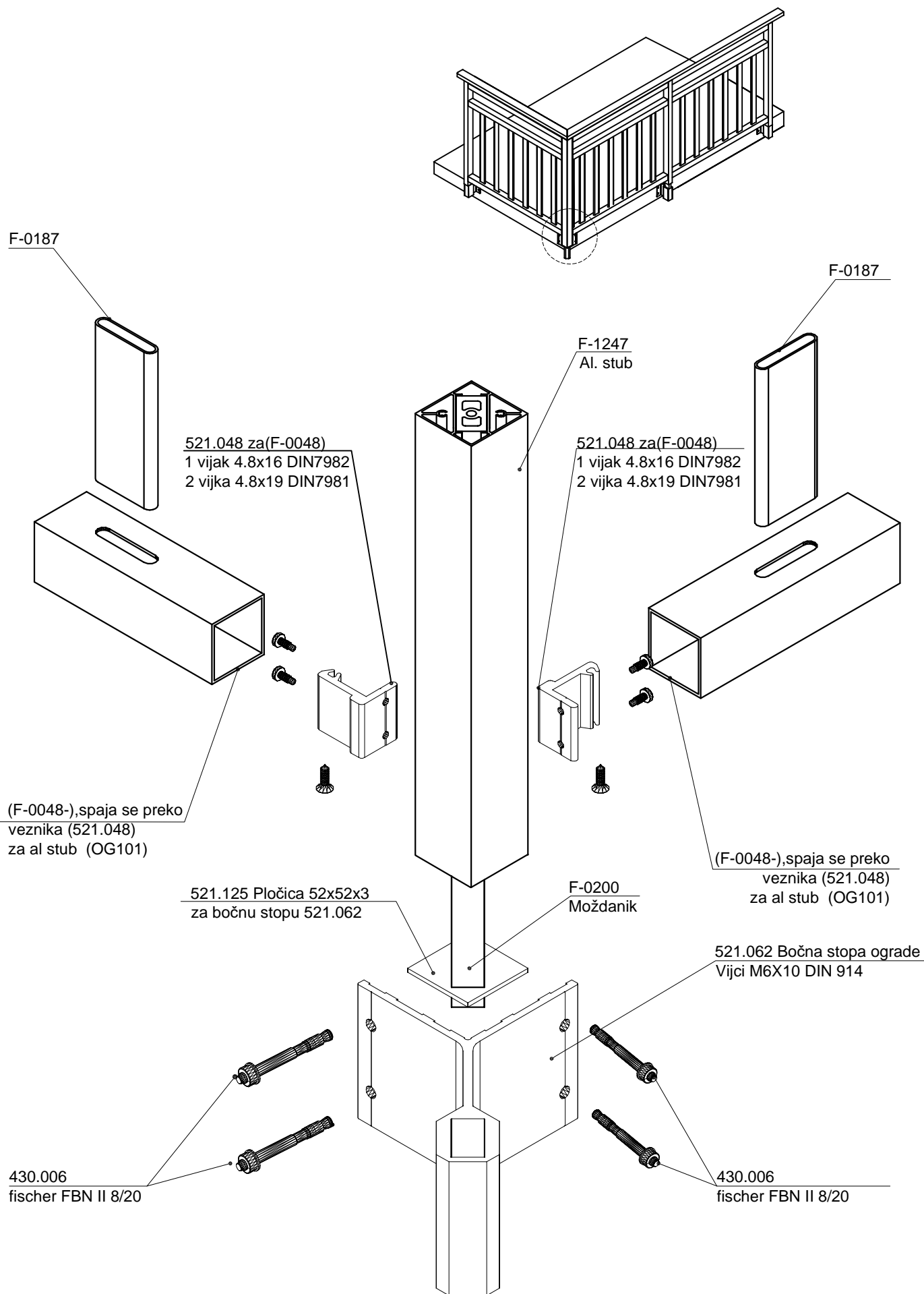

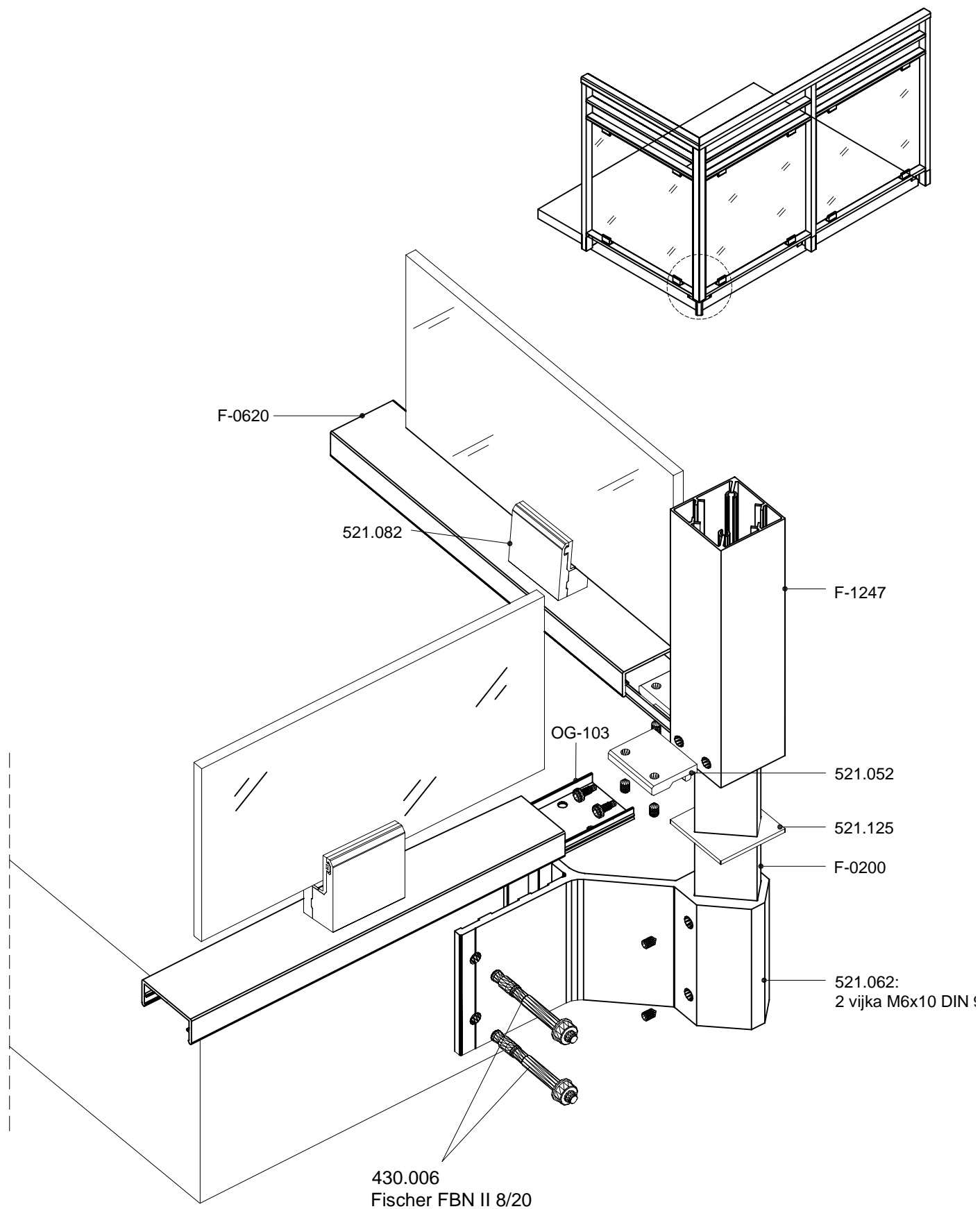

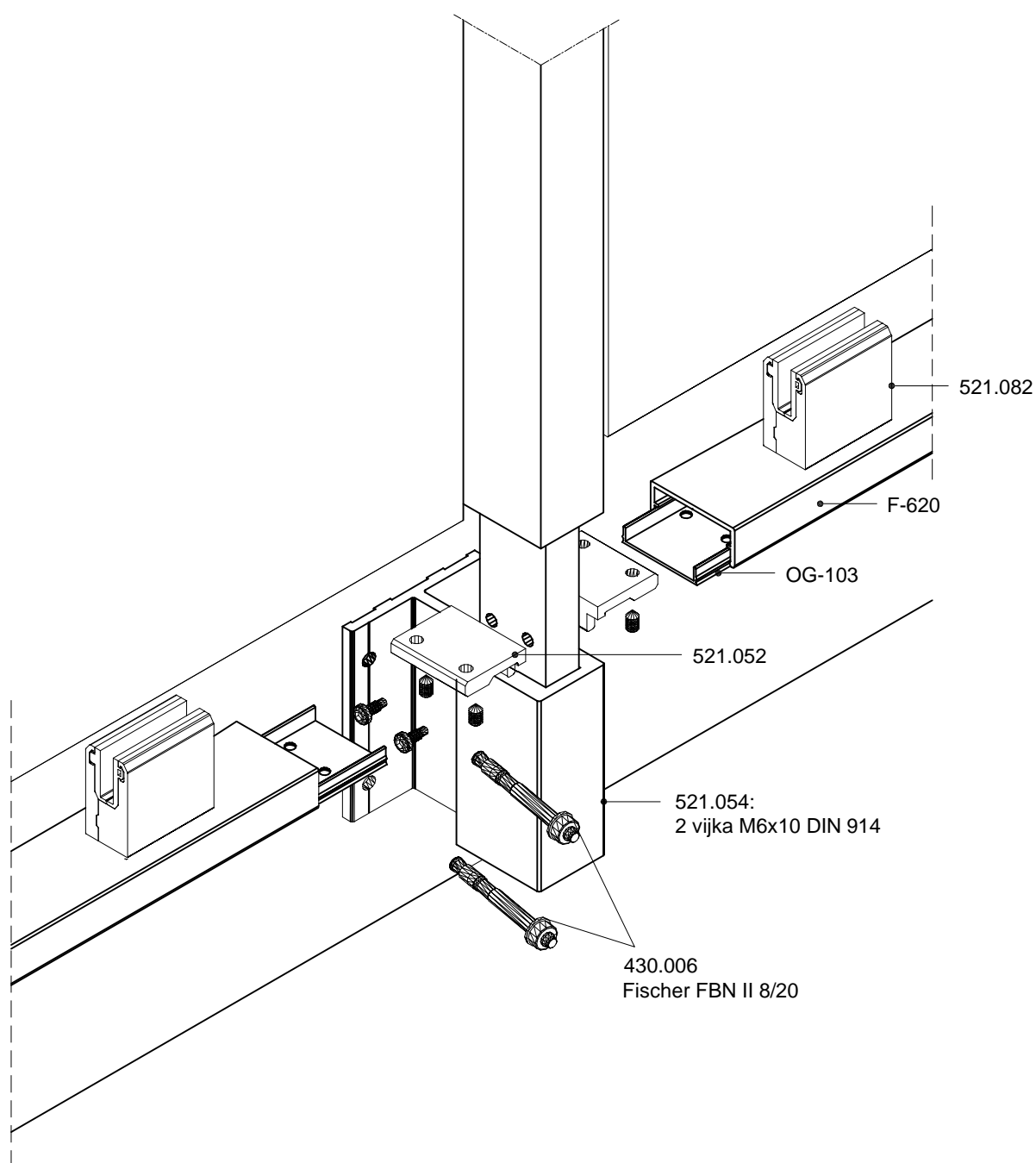
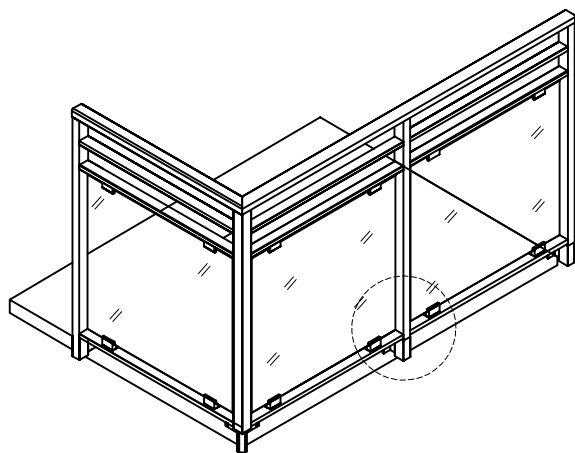

2 vijka 4.8x19 DIN7981
1 Vijak M8x30 DIN 933
za spajanje (F-0620)
podrukhovata sa
al. stubom (F-1246)

Vijci 4.8x19 DIN7981
za spajanje (F-0620)
podrukhovata
sa (OG-111)

F-0689
Rukohvat

F-0620
podrukhovlat

373.007
PVC Čep

OG-111

OG-111

F-0620

OG-103

521.044
Stopa ograde pod kutom

H(F-0200)

H(F-1246)

30°

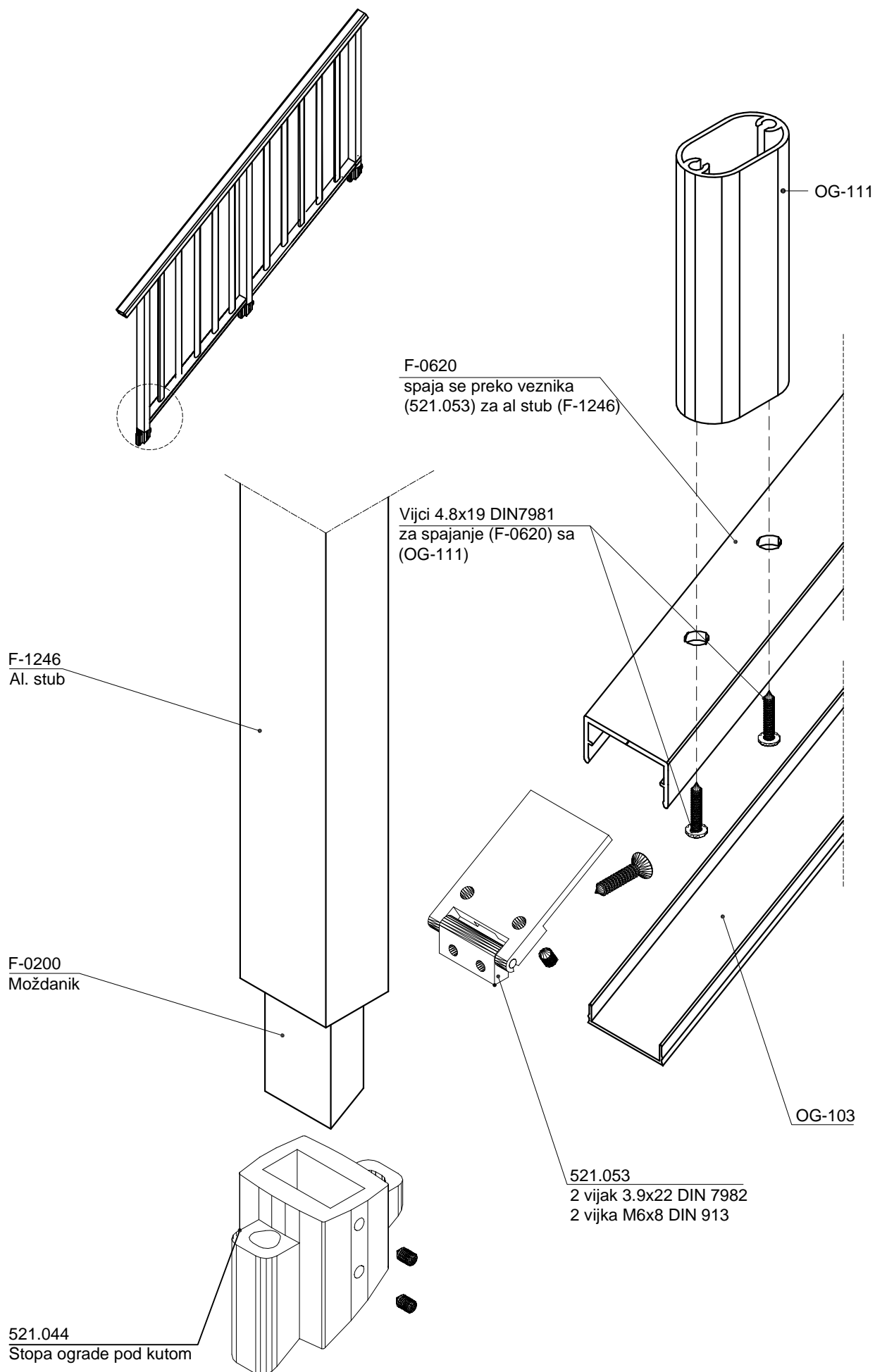

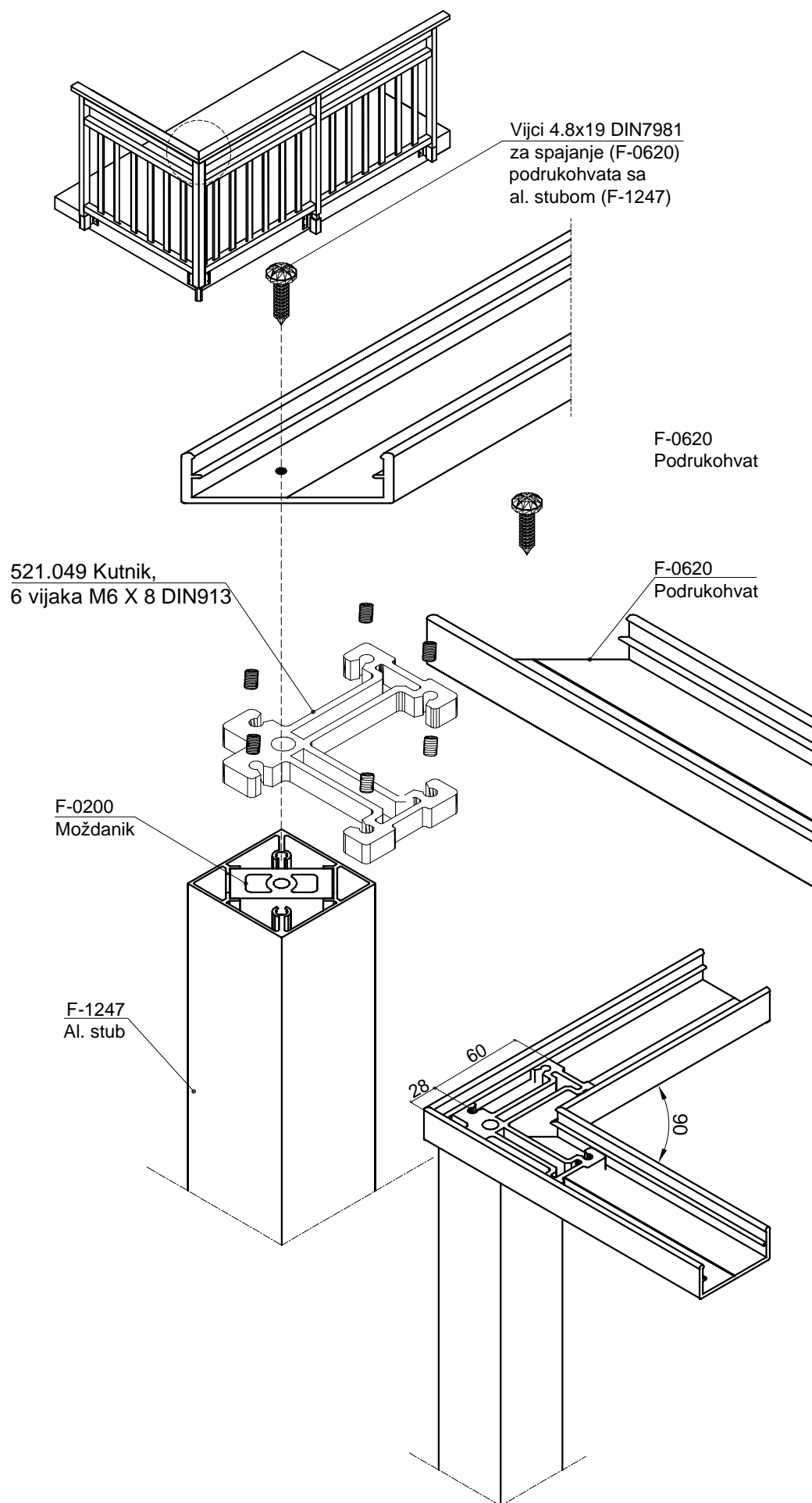

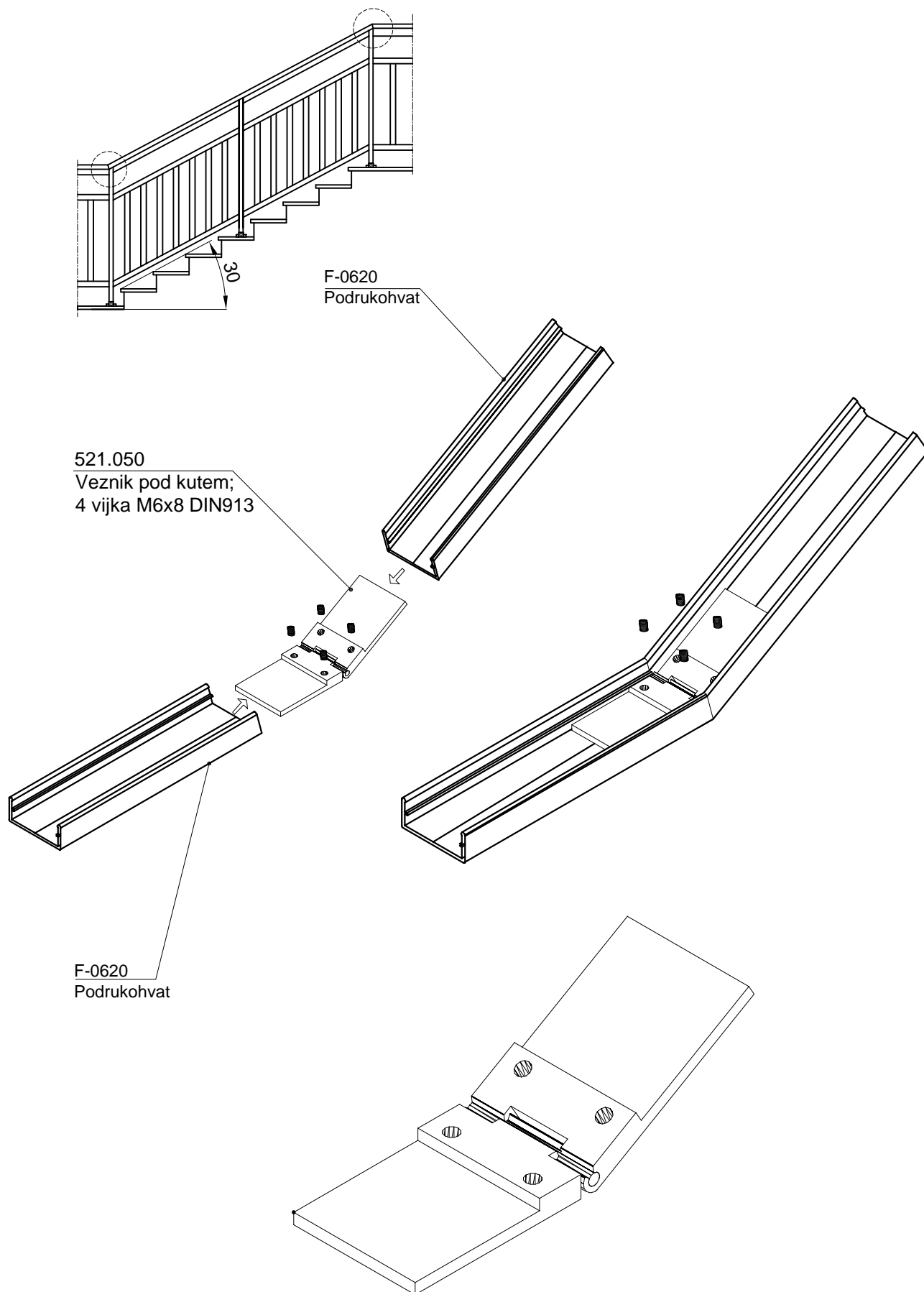

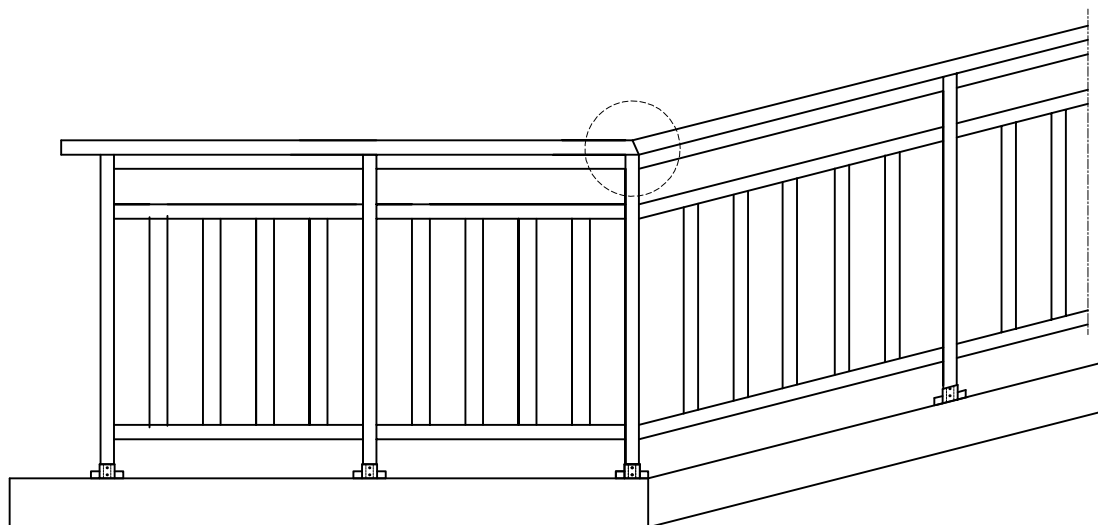

521.051
 Veznik pod kutem;
 4 vijka M6x8 DIN913

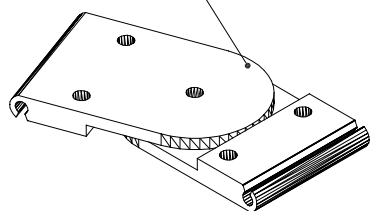

OG-V-03

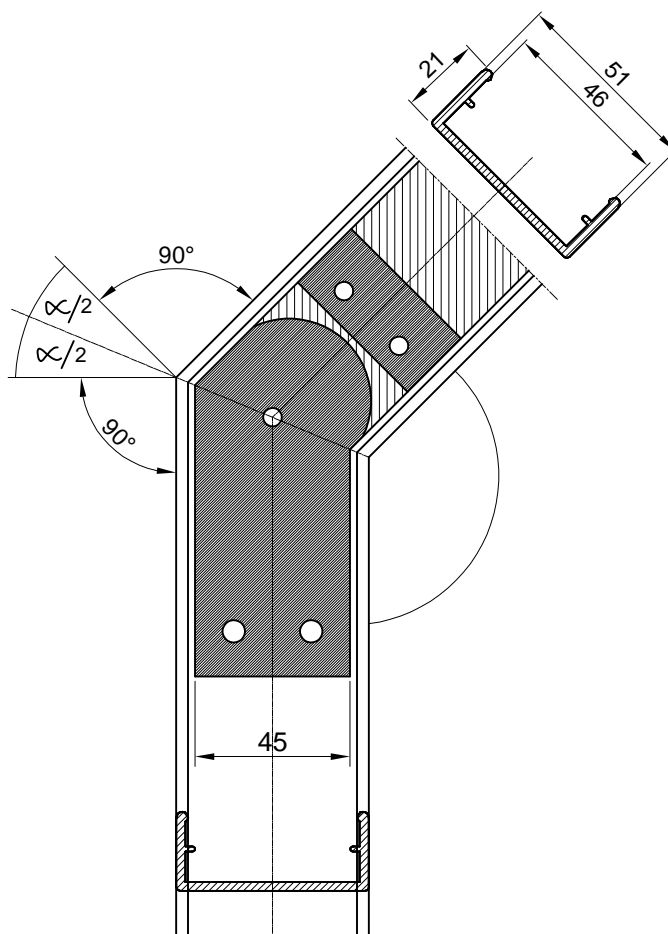

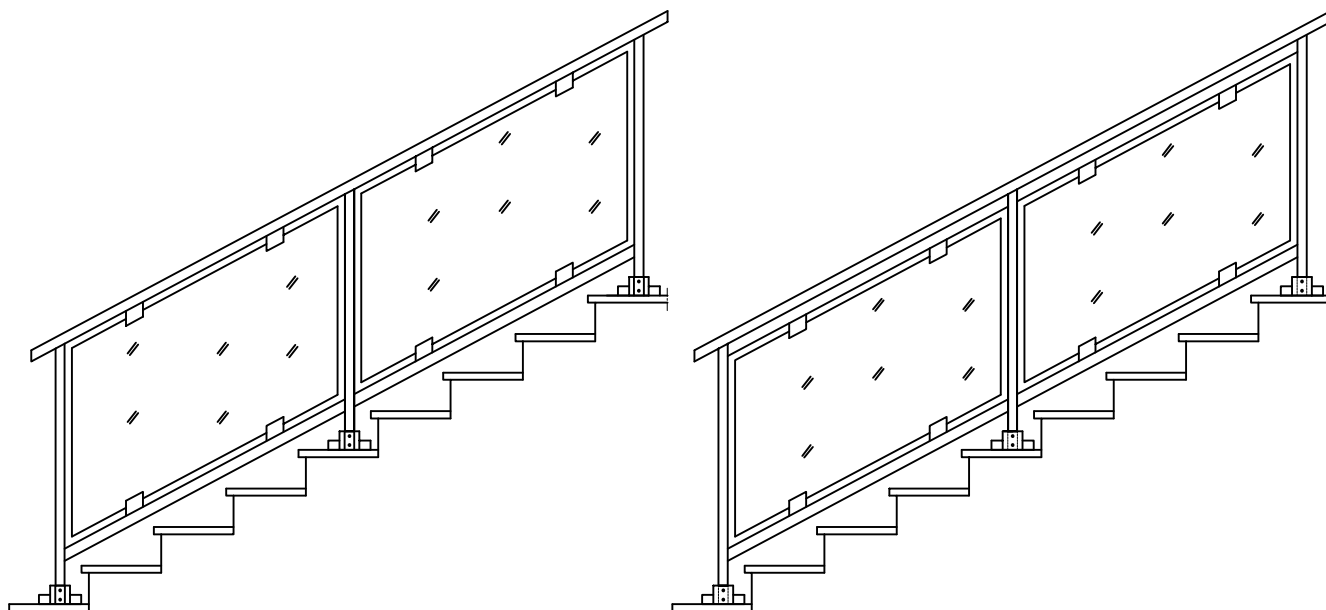

521.046 KOSI DRZAC

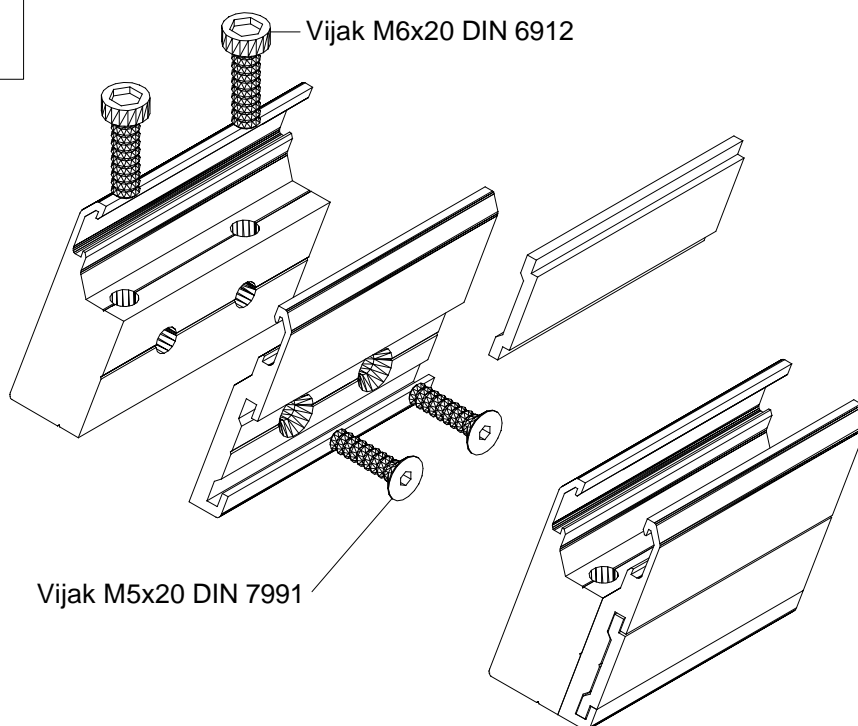
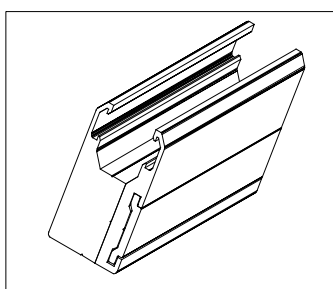

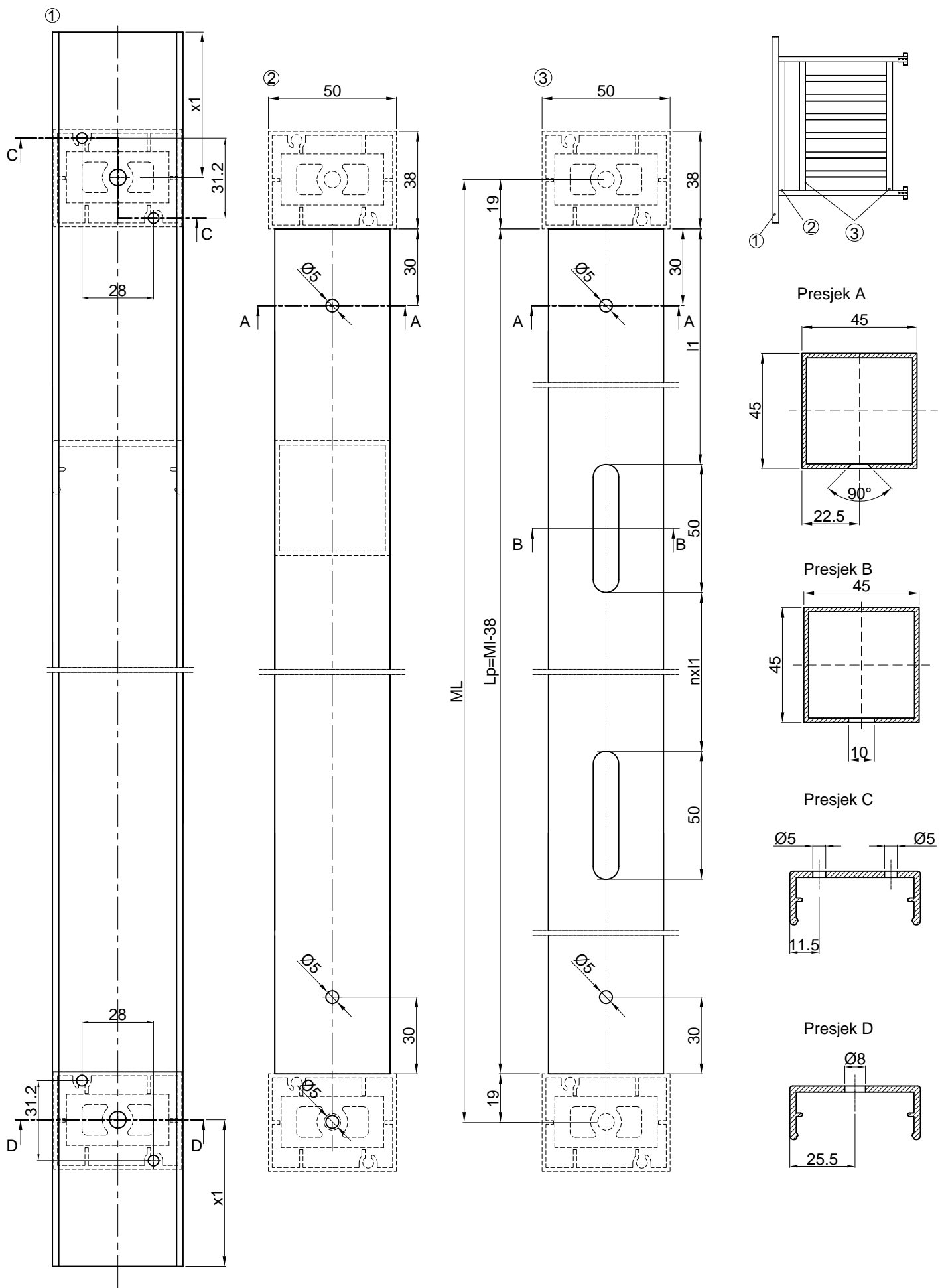

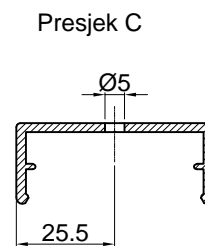
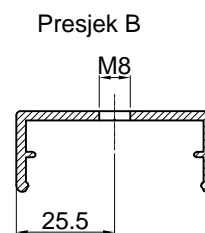
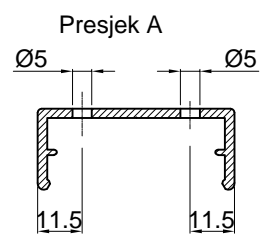
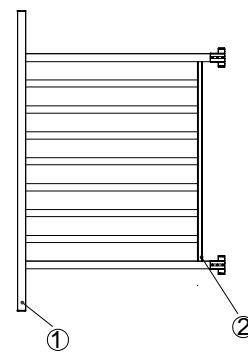
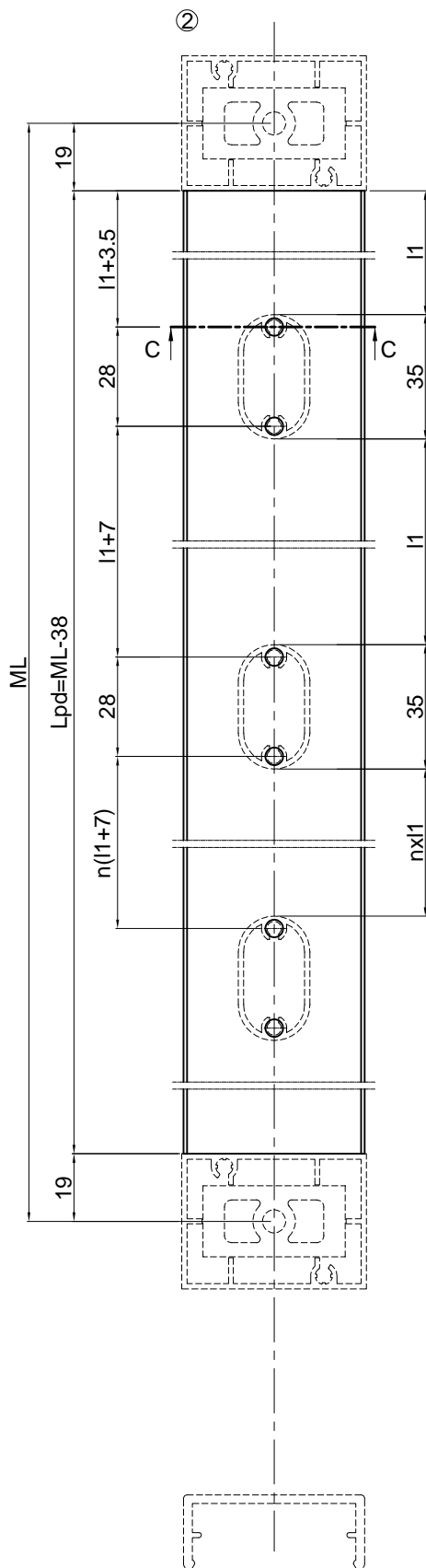
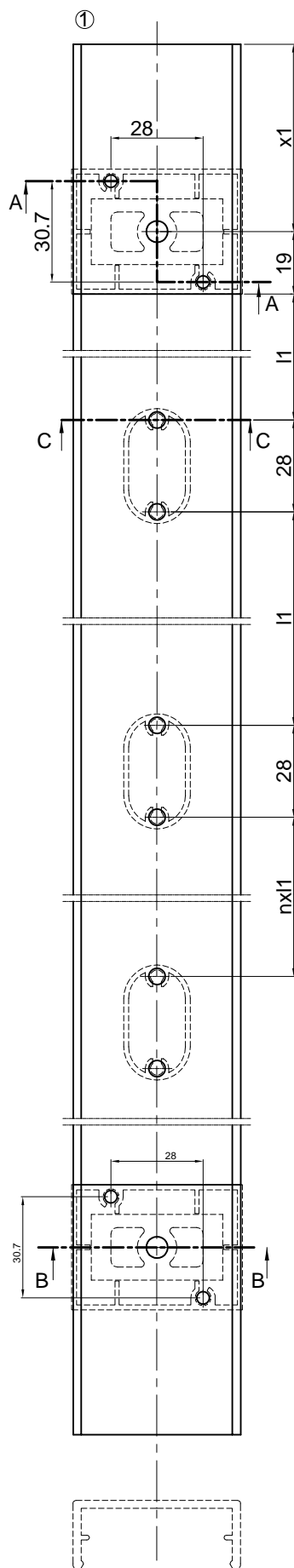

Rezne liste

TIP A

Aluminjska ograda sa ispunom F-0187 F-0187/A F-0187/L

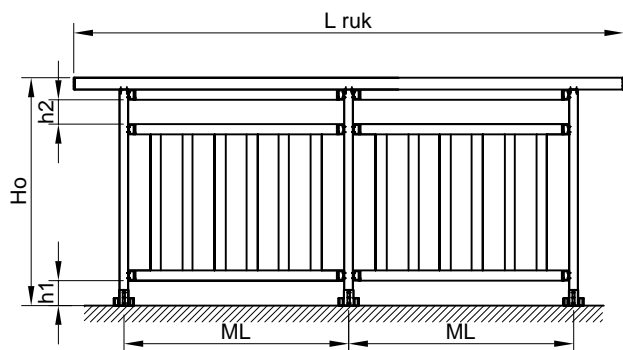

naziv	mjera	kom.	pilanje
Profili			
Moždanic F-0200 H=Ho-40	3	90-90
Maska moždanika OG-101 H=Ho-110	3	90-90
Prečka podrukohvatom F-0048 L=ML-38	2	90-90
Srednja prečka F-0048 L=ML-38	2	90-90
Donja prečka F-0048 L=ML-38	2	90-90
Podrukohvat F-0620 L ruk	1	90-90
Rukohvat F-0689 L ruk	1	90-90
Ispuna F-0187 Hisp=Hog-(88.6+h1+h2)		90-90

Vezni elementi

Stopa ograde 521.043	3	
Veznik 521.048	12	
Bočni čep rukohvata 373.007	2	

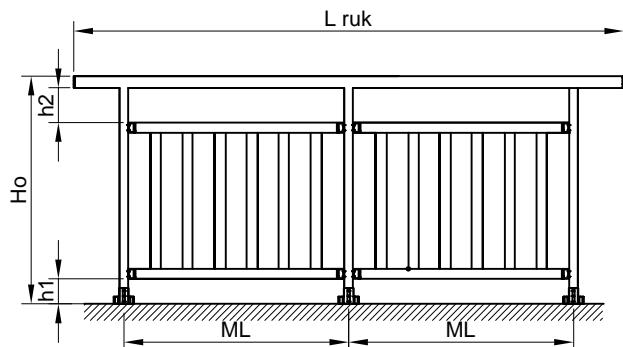

naziv	mjera	kom.	pilanje
Profili			
Moždanic F-0200 H=Ho-40	3	90-90
Maska moždanika OG-101 H=Ho-110	3	90-90
Gornja prečka F-0048 L=ML-38	2	90-90
Donja prečka F-0048 L=ML-38	2	90-90
Podrukohvat F-0620 L ruk	1	90-90
Rukohvat F-0689 L ruk	1	90-90
Ispuna F-0187/A Hisp=Hog-(89+h1+h2)		90-90

Vezni elementi

Stopa ograde 521.043	3	
Veznik 521.048	8	
Bočni čep rukohvata 373.007	2	

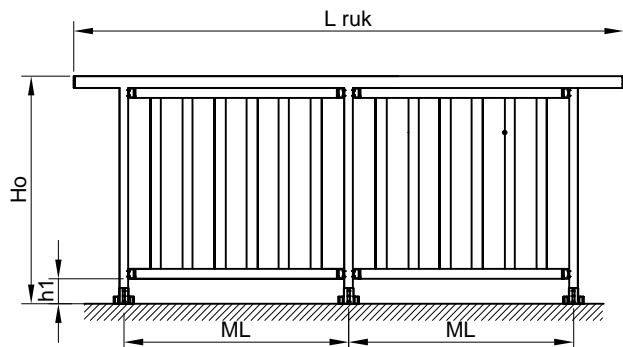

naziv	mjera	kom.	pilanje
Profili			
Moždanic F-0200 H=Ho-40	3	90-90
Maska moždanika OG-101 H=Ho-110	3	90-90
Prečka podrukohvatom F-0048 L=ML-38	2	90-90
Donja prečka F-0048 L=ML-38	2	90-90
Podrukohvat F-0620 L ruk	1	90-90
Rukohvat F-0689 L ruk	1	90-90
Ispuna F-0187/L Hisp=Hog-(89+h1+h2)		90-90

Vezni elementi

Stopa ograde 521.043	3	
Veznik 521.048	8	
Bočni čep rukohvata 373.007	2	

TIP B

Aluminjska ograda sa ispunom OG-111

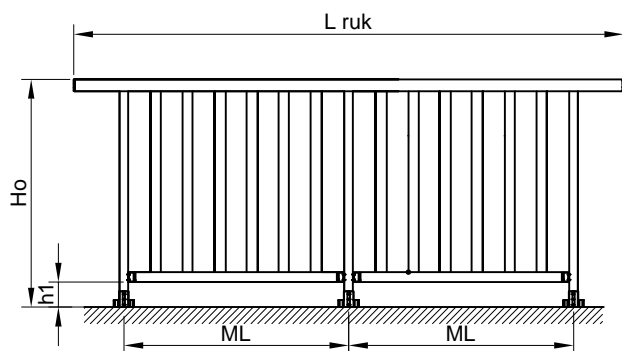

naziv	mjera	kom.	pilanje
Profili			
Moždanic F-0200 H=Ho-40	3	90-90
Maska moždanika OG-101 H=Ho-110	3	90-90
F-620 L=ML-38	2	90-90
OG-103 L=ML-38	2	90-90
Podrukohvat F-0620 L ruk	1	90-90
Rukohvat F-0689 L ruk	1	90-90
Ispuna OG-111 Hisp=Hog-(h1+60.5)		90-90

Vezni elementi

Stopa ograde 521.043	3	
Veznik 521.052	4	
Bočni čep rukohvata 373.007	2	

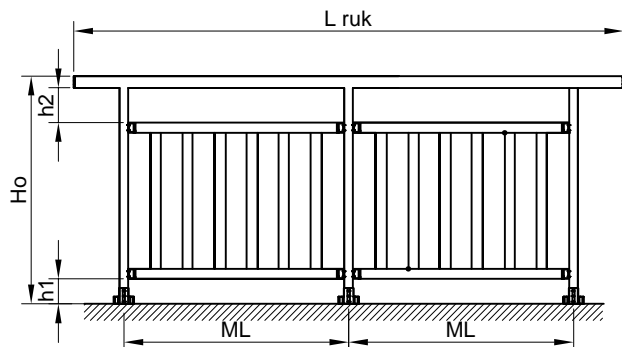

naziv	mjera	kom.	pilanje
Profili			
Moždanic F-0200 H=Ho-40	3	90-90
Maska moždanika OG-101 H=Ho-110	3	90-90
F-620 L=ML-38	4	90-90
OG-103 L=ML-38	4	90-90
Podrukohvat F-0620 L ruk	1	90-90
Rukohvat F-0689 L ruk	1	90-90
Ispuna OG-111 Hisp=Hog-(h1+h2+60.5)		90-90

Vezni elementi

Stopa ograde 521.043	3	
Veznik 521.052	8	
Bočni čep rukohvata 373.007	2	

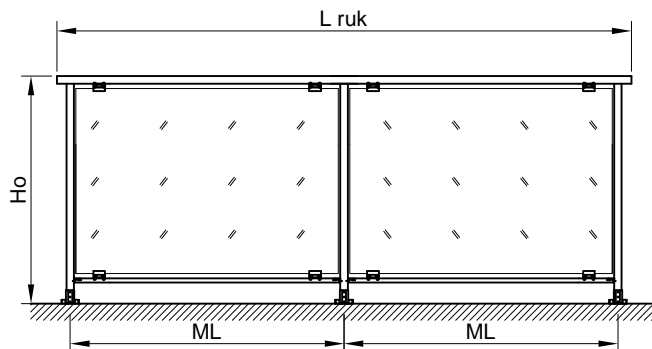
TIP C
 Staklena ograda

naziv	mjera	kom.	pilanje
Profili			
Moždanik F-0200 H=Ho-40	3	90-90
Maska moždanika OG-101 H=Ho-110	3	90-90
Donja prečka F-0620 L=ML-38	2	90-90
Maska prečke OG-103 L=ML-38	3	90-90
Podrukohvat F-0620 L ruk	1	90-90
Rukohvat F-0689 L ruk	1	90-90

Vezni elementi

Stopa ograde 521.043	3	
Držaš stakla (44.2) 521.045	8	
Veznik 521.052	4	
Bočni čep rukohvata 373.007	2	

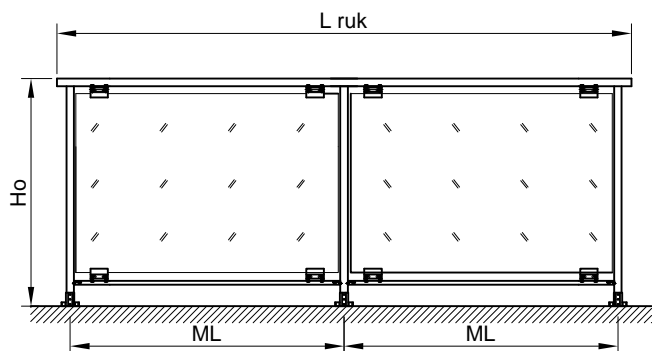

naziv	mjera	kom.	pilanje
Profili			
Moždanik F-0200 H=Ho-40	3	90-90
Maska moždanika OG-101 H=Ho-110	3	90-90
Donja prečka F-0620 L=ML-38	2	90-90
Maska prečke OG-103 L=ML-38	3	90-90
Podrukohvat F-0620 L=ML+x1+x2	1	90-90
Rukohvat F-0689 L=ML+x1+x2	1	90-90

Vezni elementi

Stopa ograde 521.043	3	
Držaš stakla (55.2) 521.082	8	
Veznik 521.052	4	
Bočni čep rukohvata 373.007	2	

FEAL

OF 60

Lipanj 2023. / *June 2023*

FEAL d.o.o.
Trnska cesta 146
88220 Široki Brijeg
Bosna i Hercegovina
Tel. +387 39 704-269; 705-807; 705-636
Fax. +387 39 704-358
info@feal.ba
www.feal.ba